



Enerdrive *Lithium Power Pack*



LITHIUM-ION BATTERY SYSTEM OWNER'S MANUAL 2018/2019

With ePRO Plus Battery Monitor

LITHIUM-ION BATTERY SYSTEM

After 2 years of research, testing and proving, and a further 6+ years of infield sales, Enerdrive has designed and created a COMPLETE Lithium Battery & Installation System so your Li-Ion battery bank is fully protected. Most importantly, our system is designed to give the maximum performance, longevity and SAFETY in your valuable installations.

Be aware that the market is abuzz with the hot topic of Lithium Ion Batteries; and we can tell you from our testing to date that all the hype of their performance and capabilities is TRUE. However what we can also inform you is that all the stories of their 'Issues' are unfortunately also true. However the so called "issues' of lithium can be avoided with some very basic rules about protection.

- Never go over voltage whilst charging them
- Never let them go 'Dead' Flat
- Keep the individual cells 'Balanced'

What this lesson taught us is if we were to develop our lithium program – IT HAD TO BE DONE RIGHT.

So we developed our own Lithium Power Pack for the Australian market with the emphasis on 'built like a tank'; and even to the extent of being a little bit 'overkill' on the packaging and protection.

So how does our system actually work?

The Advance BMS relay driver is designed to take multiple signal input connections from the ePRO Plus battery meter for low state of charge (SOC%) & system voltage & Hi/Low Cell voltage from the batteries Active Cell Balancer unit and control all charging and discharging sources connected to the lithium battery system.

System Program Selection Switch;

The Enerdrive Advanced BMS Relay Driver has 2 pre-programmed settings.

PROGRAM A:

This program isolates the charging sources (solar/vehicle/mains charger) in the event of a battery cell voltage being too high without turning the whole electrical system off. The Enerdrive Advanced BMS Relay Driver will activate the TOR & output contacts that will cut out all charging sources for 10 minutes. If the cell has not come back within range before 10 minutes, it will stay active for another 10 minutes and repeat until the cell/s are within range. This setup allows the system loads to still be powered.

FOR SYSTEMS INSTALLED WITH ePOWER AC, DC2DC CHARGERS & ePOWER INVERTERS:

In the event of low SOC% and/or voltage, the main battery relay will disengage to protect the battery. All charging sources (solar/vehicle/mains charger) will still be active to recharge the battery providing the sun is up or the chargers are plugged in. To re-engage the main battery relay, press in the Yellow button on top of the main battery relay. The Enerdrive Advanced BMS Relay Driver will turn the main battery relay OFF every 6 minutes if the SOC% on the battery monitor is still below the set point. So this may need to be reset a few times before the SOC% set point reaches its re-engagement point.

FOR SYSTEMS INSTALLED WITH COMBI INVERTER/CHARGERS:

In the event of low SOC% and/or voltage reaches the pre-set level, the program will shut down the charging sources (solar/vehicle) and the inverter/charger before disengaging the main battery relay, turning off the whole electrical system to protect the battery. The program will then switch on the signal for all charging sources. When AC power is applied to the Combi, the AC charger will start once the main latching relay is re-engaged. To re-engage the main battery relay, press in the Yellow button on top of the main battery relay.

The Enerdrive Advanced BMS Relay Driver will turn the main battery relay OFF every 6 minutes if the SOC% on the battery monitor is still below the set point. So this may need to be reset a few times before the SOC% set point reaches its re-engagement point.

PROGRAM B:

This program is used if the temperature sensor fails. By selecting Program B, the temperature sensor is ignored allowing for operation of the system until you can replace the faulty temperature sensor. Running this program will get you into "Limp-Home Mode" but you will have no temperature control on the system thus leaving the lithium protection system compromised. Contact Enerdrive to arrange for a replacement Temperature Sensor.

Active Cell Balancing:

Cell balancing is designed to equalise the charge on every cell in the pack and prevent individual cells from becoming over stressed thus prolonging the life of the battery.

The Enerdrive Lithium battery packs incorporate Active Cell Balancing across the range. The balancing method used is Dynamic Energy Transfer. This allows for automatic balancing of the cells during charging, discharging and storage. Any cells with higher voltage density will transfer energy to the lower cells in the pack. This method of cell balancing utilises the energy within the battery pack to balance the cells unlike passive balancing systems which bleed this excess energy off as heat to keep the battery balanced, wasting energy already stored within the battery.

The Enerdrive Active Balancing System also incorporates individual cell "Hi-Voltage & Low-Voltage" disconnect feature for signal switching (off/on) of charging sources & consumer loads.



Main Battery Relay & Active Cell Balancer.

So what's so advanced about the Advance BMS Relay Driver?

- 4 x "TOR" Circuits – Programmed to control Enerdrive ePOWER AC & DC2DC Chargers, & Morningstar Solar Controllers (Hi/Low Alarm Protection).
- 4 x Normally Open/Closed/Common Contacts (10 Amps Max) – programmed to switch trigger contacts/relays connected to Alternators*, Chargers, Solar or DC/AC relays, cabinet cooling fan and Combi Inverter/Charger Units. (Hi/Low Alarm Protection).
- 1 x Temperature Sensor input – to control charging/discharging circuits
- 1 x Latching Relay Output – Used to shut down system loads to protect the battery from over discharge.

**Requirements of Alternator must be assessed to determine if suitable for the application.*

Status LED

The Advanced BMS Relay Driver is equipped with a "Status" LED indicator to respond to certain conditions that the Relay Driver is experiencing. Status condition is as follows;

- **No Status LED:** All Components are operating under normal conditions
- **Flashing Green LED:** The system has registered an alarm condition from Inputs 1 or 2 and will activate LOW SOC/Low Cell safety program
- **Flashing Red LED:** The System has registered an alarm condition via high cell voltage ($\geq 3.80V$ per cell) shutting down all charging circuits. When voltage drops below $3.60V$ per cell, charge circuits will switch back on.
- **Solid Red LED:** The System has registered an alarm condition via a high temperature ($\geq 45^{\circ}C$) shutting down all charging circuits. When temperature drops below $45^{\circ}C$, load circuits will switch back on.
- **Flashing Red/Blue LED:** The System has registered an alarm condition via a high temperature ($\geq 55^{\circ}C$, load circuits will switch off.

Temperature Sensor

The temp sensor input is monitoring temperature via the connected sensor within the surrounding space of the sensor. The system is programmed to act on pre-determined temperature readings to control the output circuits. These programmed parameters are;

- At $\geq 35^{\circ}C$, activates Output No 4 for controlling connected Cabinet Fan cooling.
- At $\geq 45^{\circ}C$, activates TOR Controls 1-4 and Outputs 1-2 to shut down charging sources to protect battery from overcharge in extreme heat conditions.
- At $\geq 55^{\circ}C$, activates Latching Relay to disengage load circuit to protect battery from overheating in extreme heat conditions. $< 55^{\circ}C$ this system will re-engage the latching relay to power the application
- At $\leq 0^{\circ}C$, activates TOR Controls 1-4 and Outputs 1-2 to shut down charging sources to protect battery from charge input in extreme cold conditions.

Status LED

- Flashing GREEN - LOW SOC% <24% or LOW CELL Voltage <2.8V/Cell (Load Shutdown)
- Flashing RED - HIGH CELL Voltage >3.8V/Cell - Charger Shutdown
- Solid RED - High Temp Charger Shutdown >45°C (Charger Shutdown)
- Flashing RED/BLUE - Extreme Temp System Shutdown >55°C (Charge & Load Shutdown)

- When Red LEDs are on, all output circuits are disabling connected charge sources.
- When Red LEDs are off, all output circuits are within range and operating correctly.
- When Red ePRO Combi Inverter shutdown (if connected)
- OUTPUT 4 Cabinet Cooling Fan Control Turns ON >35°

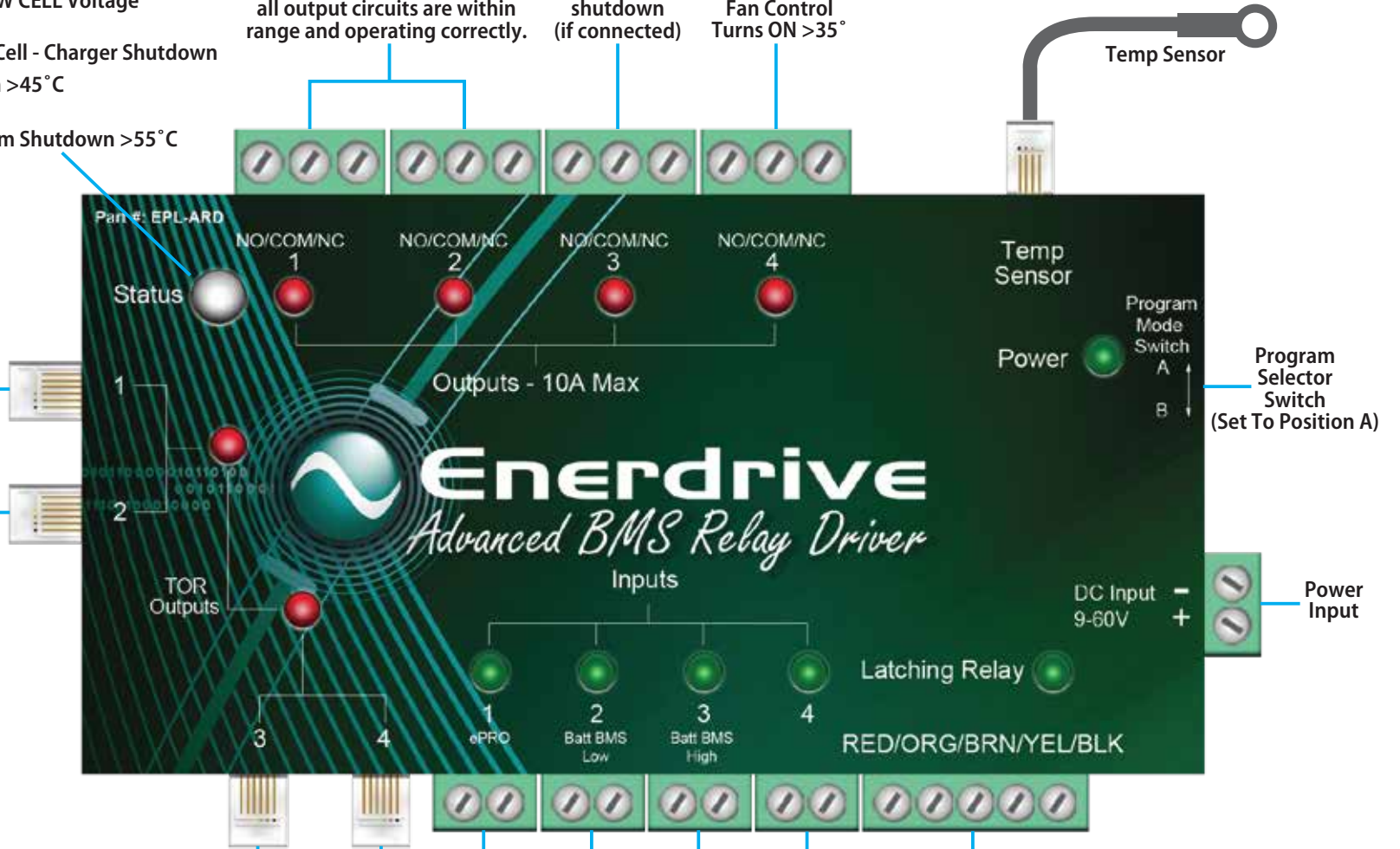

- When Red LEDs are on, all output circuits are disabling connected charge sources.
- When Red LEDs are off, all output circuits are within range and operating correctly.

- When Green LEDs are on, all input circuits are within range and operating correctly.
- When one or more Green LEDs are out, the input is receiving an alarm signal from the connected equipment.

- When Green LED is on, the connected latching relay is engaged and operating correctly.
- When Green LED is off, the connected latching relay is disengaged shutting power to all output loads.

What's in the Enerdrive Lithium System?

To use the Enerdrive Lithium Power Pack you need to use a combination of items together. These are:

- The actual lithium power pack battery box including Active Balancing System.
- The Advance BMS controller board which includes
- The Advance BMS Relay Driver box
- The ePRO Plus is our latest generation, highly advanced battery monitor. It consists of an intelligent active shunt and a remote control and display unit (CDU). The shunt has a Grid Optimized footprint for perfect integration with our DC Modular series of high current busbars and fuse holders.

The ePRO Plus battery monitor can measure DC currents up to 600Amps (500Amp continuous) and voltages up to 70Vdc. So any lead- or lithium based battery from 12V up to 48V can be monitored.

- A Blue Sea 500amp main battery latching relay which is activated by the ePRO Plus Battery Monitor when the low state of charge (percentage is reached).
- A Class T Fuse for system protection.
- 70 - 120mm² Battery cable (depending on system) from the battery to the Connection Kit.

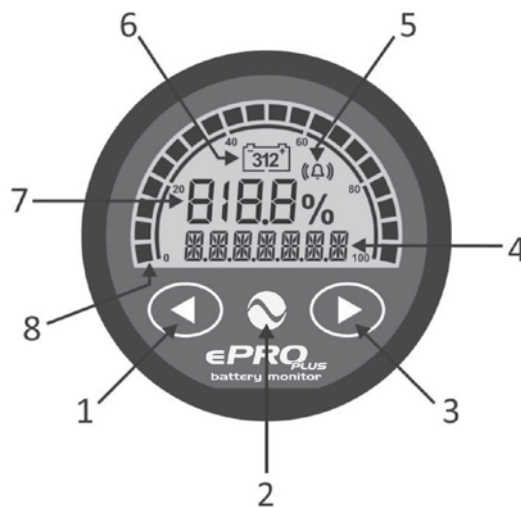

- 1 Left key (<) or Previous value
- 2 Menu or Enter key
- 3 Right key (>) or Next value
- 4 7 character multipurpose information field
- 5 Alarm indicator
- 6 Selected battery input indicator
- 7 Value section for SoC (also for Function, Status and History parameter numbers)
- 8 State of Charge (SoC) bar. 0 – 100% grid will show an animation when there is a charge current (turning clockwise) or a discharge current (turning counter clockwise). The animation speed will also increase when the charge or discharge current increases.



State of charge (%)



Status or history readout



Volt, Amp, Ah, time remaining, temperature, Watts, and maintenance hours.



Alarm activated (low battery state of charge)

The ePRO Plus Battery Monitor has been pre-programmed at the factory to suit the selected Lithium system and is software locked. There is no setup interaction required by the end user. For more user information on the ePRO Plus Battery Monitor, please refer to the detailed instruction manual included in your documentation package.

Voltages for Lithium batteries have a very narrow window compared to lead acid batteries. With all of our testing over the last 6+ years, the Enerdrive Lithium battery standing voltage when fully charged (with no loads running) will be between 13.35v-13.45v at 100% capacity.

When discharged to near 25% capacity remaining, the standing voltage will be between 12.90v-13.00v

As you can see, the voltage variance between 100% full and 25% full is only 0.55v. This is quite different to lead acid batteries where voltage can range from 12.72v at 100% to 11.88v at 20% capacity.

With Lithium, it is better and more accurate to work on the State of Charge Percentage (SOC%) to determine your remaining battery capacity.

PLEASE NOTE

The battery has a self-discharge rate of 5% per month @ 25°C. When storing the battery with the main latching relay disengaged, the ePRO Plus Battery Monitor and Advance Relay Driver will still be powered, adding a further drain on the battery.

It is the responsibility of the end user to maintain the battery in a charged state. The battery should not be left for more than 30 days without checking its charge state. Enerdrive recommend that a battery left in a "storage state" should be checked and charged as often as possible (maximum 30 days) to maintain maximum life expectancy of the battery. Failure to follow these requirements will see an early failure of the battery which is not covered under warranty.

BATTERY STORAGE INFORMATION:

IMPORTANT PLEASE READ:

When storing your Enerdrive lithium battery, even with the main Remote Battery Switch disengaged, the ePRO PLUS Battery Monitor and Advanced BMS Relay Driver will still be powered, producing a small constant drain on the lithium battery. Therefore, it is essential that you keep your Enerdrive lithium battery charged when you are not using your vehicle/vessel. It is the responsibility of the end user to maintain the Enerdrive lithium battery in a charged state.

Your lithium battery should not be left for more than 30 days without checking its charge state. Enerdrive recommend that your lithium battery should ideally be checked and charged as often as possible to maintain maximum life expectancy, especially if you leave any DC loads running. Failure to follow these requirements could see an early failure of the battery, which is not covered under warranty.

When you are not using your Enerdrive lithium system it is strongly recommended that you switch off ALL DC loads and keep the vehicle/vessel plugged into AC power. If you do not have access to AC power then leave your vehicle/vessel in the sun to allow your solar panels (if installed) to keep the battery charged.

If you store your vehicle/vessel under cover and you don't have access to AC power, then you must prevent the battery from being discharged to a critical, potentially non-recoverable, state of charge. Before your battery state of charge reaches 24% you must either connect your vehicle/vessel to AC power or move it into the sun and allow the solar (if installed) to bring the battery up to a reasonable state of charge. In either case, it would make sense to fully charge your lithium battery to 100% in order to increase the period of time before you have to repeat this procedure.

If your vehicle/vessel is connected to AC power and is being left unattended for longer than 30 days, and will not be checked by yourself, we recommend that you either ask someone to check on it regularly while you are away or follow the long term storage procedure in the following pages.

Long Term Storage Switch

----- Failure to correctly store your lithium batteries will result in early battery failure -----



If you are intending to store your vehicle/vessel for more than 30 days, it is recommended to shut down the entire DC electrical system. You can do this by turning off the Long Term Storage Switch (if installed). This switch is designed to completely isolate the Enerdrive lithium battery from the DC electrical system, including the ePRO PLUS battery monitor and Advanced BMS Relay Driver and will prevent any external discharge of the lithium battery.

Steps to put the lithium battery into long term storage:

1. Fully charge the Enerdrive lithium battery until the charge device/s enters the "Float/FUL" stage and the ePRO PLUS battery monitor reads 100%.
2. Turn off AC charging devices.
3. Disconnect the AC mains supply from the AC inlet socket on the vehicle/vessel.
4. If you have solar panels installed isolate them from the solar charge controller to avoid any possible damage to the solar charge controller when disconnecting the battery.
 - **NOTE:** If you can't safely isolate your solar panels during daylight hours wait until night time then continue with the following steps.
5. Disengage the Remote Battery Switch by turning the yellow knob fully to the right (LOCK OFF position) until the centre of the knob pops up. (See Remote Battery Switch label below).
6. Turn the Long Term Storage switch into the OFF position.

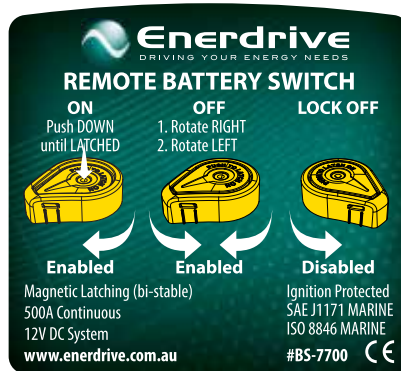

The Enerdrive lithium battery is now in long term storage. All battery monitoring and protection systems are now shut down. Verify that the ePRO PLUS battery monitor's display is blank. The Enerdrive lithium battery can now be left for a period of up to 6 months. After 6 months it is recommended to re-engage the system and charge the battery.

NOTE: the Enerdrive lithium battery has a self-discharge rate of approx. 5% per month @ 25°C when in long term storage.

Steps to re-engage the lithium battery system after long term storage:

1. Turn the Long Term Storage switch into the ON position.
2. If you have solar panels installed re-connect them to the solar charge controller.
3. Engage the Remote Battery Switch by turning the Yellow knob fully to the left (ENABLED position) and firmly press down the centre of yellow knob until it clicks and remains in the down position (see Remote Battery Switch label above).
4. Check all the following LED's are lit on the Advanced BMS Relay Driver: -
 - Power
 - Input 1
 - Input 2
 - Input 3
 - Input 4 (if connected)
 - Latching Relay



5. Re-connect the AC mains supply to the inlet socket on the vehicle/vessel.
6. Turn on AC charging devices.
7. Fully charge the Enerdrive lithium battery until charging device/s enters the "Float/FUL" stage and the ePRO PLUS Battery monitor reads 100%.

When the system is re-engaged the ePRO PLUS battery monitor percentage (%) will show "--" on the display. The battery monitor requires the battery to be charged fully before it will display 100% capacity.

IMPORTANT: YOU WILL NOT HAVE PROPER PROTECTION FOR YOUR LITHIUM BATTERY UNTIL THE BATTERY IS FULLY CHARGED AND THE ePRO PLUS BATTERY MONITOR READS 100%. THIS MAY TAKE UP TO 6 HOURS SUBJECT TO THE CAPACITY OF THE BATTERY. IT IS RECOMMENDED TO MONITOR THE SYSTEM UNTIL THE ePRO PLUS BATTERY MONITOR READS 100% IN CASE AC MAINS SUPPLY IS LOST DURING THE INITIAL RE-CHARGE.

Troubleshooting the Lithium Battery System

Q: What if the battery monitor reads 24% or less or the battery voltage has reached 12.4v or less, and the power has gone out?

A: The battery has reached its maximum discharge and the main battery relay has dis-engaged to protect the battery. Turn off all loads and turn on the charging sources. Once the percentage on the ePRO Plus Meter reaches 28%, you can push the yellow button on the main battery relay until it latches down to re-engage the main battery switch and monitor your loads. Keep charging sources connected until the battery reaches maximum charge 100%.

Q: What if I see red LED's on the "TOR & Outputs" of the Advanced Relay Driver?

A: If a battery cell goes Hi Voltage and cuts the HI Voltage loop wire then the Advanced BMS Relay Status LED will flash RED and the Driver will activate the TOR & Output contacts (turning red) and will drive the installed relay/contacts to cut out all charging sources (solar/vehicle/main charger) for 10 minutes. If the cell voltage has not come back within range before 10min, it will stay active for another 10 minutes and repeat until the cell/s are within range.

Q: What if the main battery switch has tripped out, but the LED's on Inputs 1-3 on the Advanced BMS Relay Driver are Green and the battery monitor is 26% or higher in capacity?

A: This has happened because the system has registered 1 of 2 faults:

1: A high temperature condition has occurred above 55°C (status LED flashing Red/Blue) and shut down the main battery relay to protect the system from an extreme high temperature situation. Once the temperature reduces below 55°C the main battery relay will automatically switch itself back on.

2: The system has registered a low battery SOC $\leq 24\%$ or low cell voltage $\leq 3.1V$ condition (Status LED flashing Green) and shut down the main battery relay to protect the battery from over discharge. If solar is connected to the system, once the SOC rises above 26% and the cell voltage increases above 3.1V then inputs 1-3 will register a Green LED. At this point, push the yellow button on the main battery relay until it latches down to re-engage the main battery switch and monitor your loads. Switch on additional charging sources until the battery reaches maximum charge 100%

Q: What if the Status light is flashing Blue and the temperature is above 0°C?

A: The Temperature Sensor has failed or become unplugged and the system has shut down the charge sources. Check to make sure the sensor is plugged in correctly. If so, remove the Temperature Sensor from the Advanced BMS Relay Driver and select Program B on the side of the Advanced BMS Relay Driver. Refer "Program B" on page ##

Lithium Setup - ePOWER Single 12v - 2018-G2

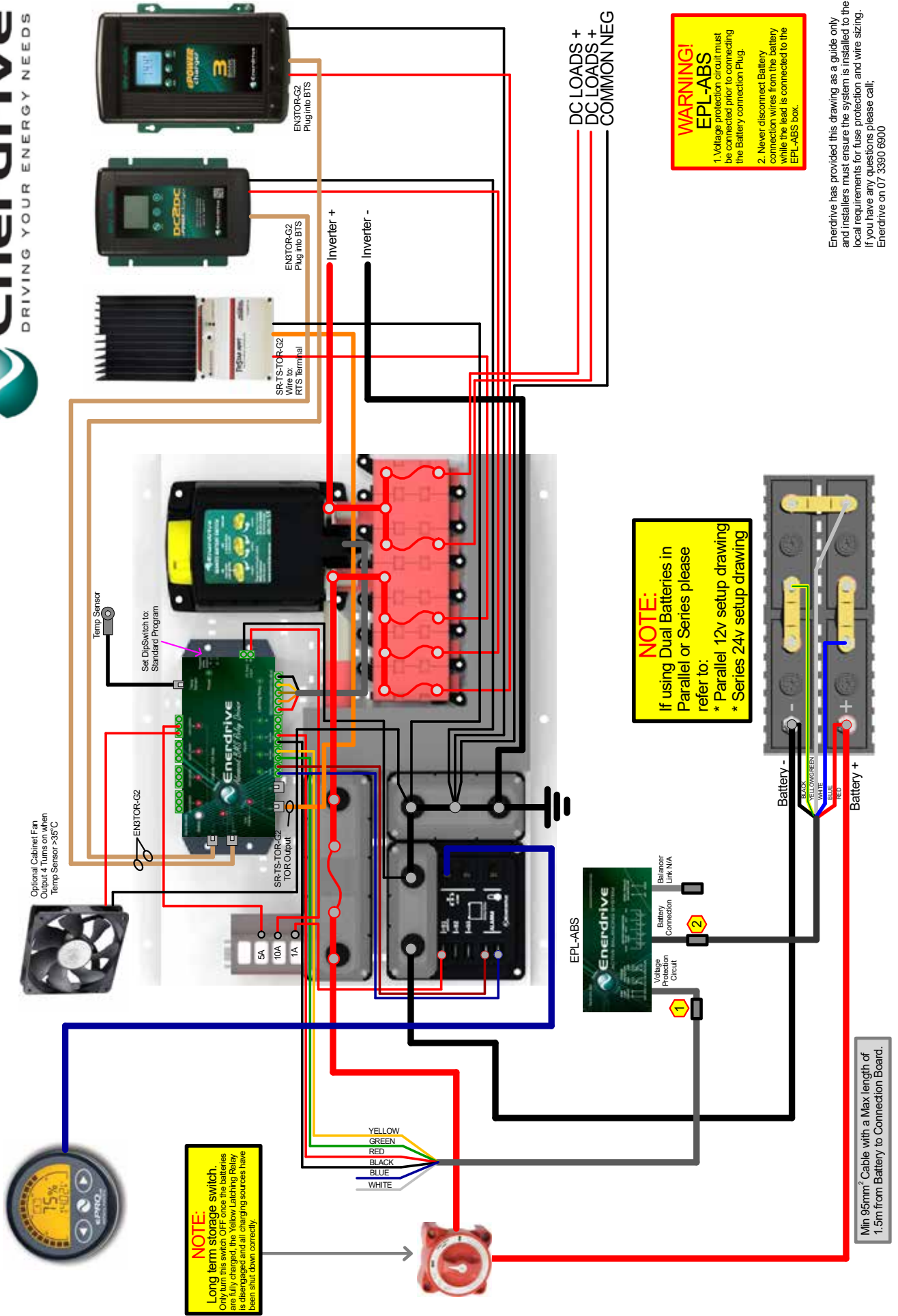

NOTE:
 Long term storage switch.
 Only turn this switch OFF once the batteries are fully charged, the Yellow Latching Relay is disengaged and all charging sources have been shut down correctly.

NOTE:
 If using Dual Batteries in Parallel or Series please refer to:
 * Parallel 12v setup drawing
 * Series 24v setup drawing

WARNING!
EPL-ABS
 1. Voltage protection circuit must be connected prior to connecting the Battery connection Plug.
 2. Never disconnect Battery connection wires from the battery while the lead is connected to the EPL-ABS box.

Enerdrive has provided this drawing as a guide only and installers must ensure the system is installed to the local requirements for fuse protection, and wire sizing. If you have any questions please call: Enerdrive on 07 3390 6900

Min 95mm² Cable with a Max length of 1.5m from Battery to Connection Board.

Lithium Setup - ePOWER Dual 12v - 2018-G2

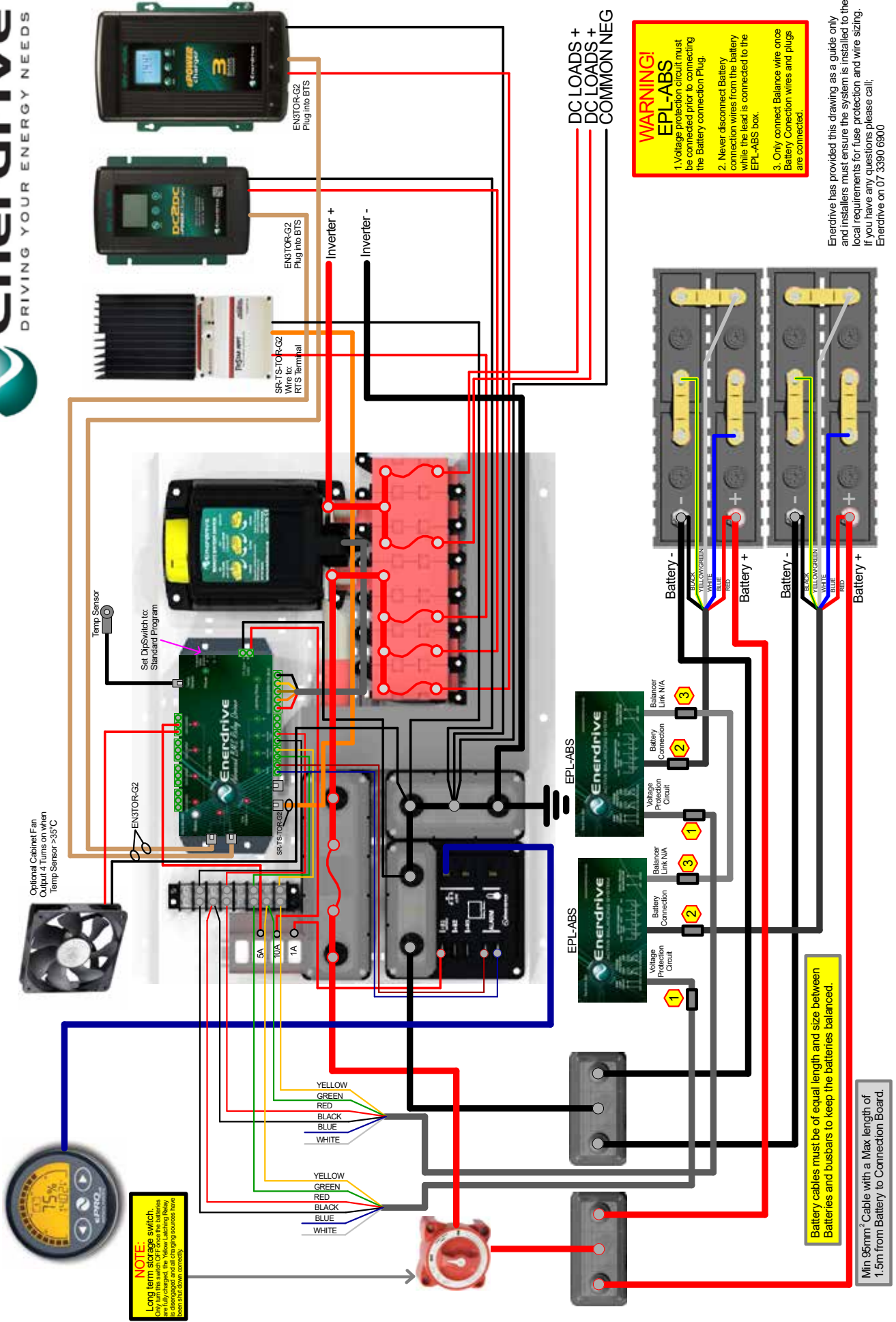

Enerdrive has provided this drawing as a guide only and installers must ensure the system is installed to the local requirements for fuse protection and wire sizing. If you have any questions please call: Enerdrive on 07 3390 6900

Lithium Setup - ePRO 1600 Single 12v - 2018-G2

13/12/2018

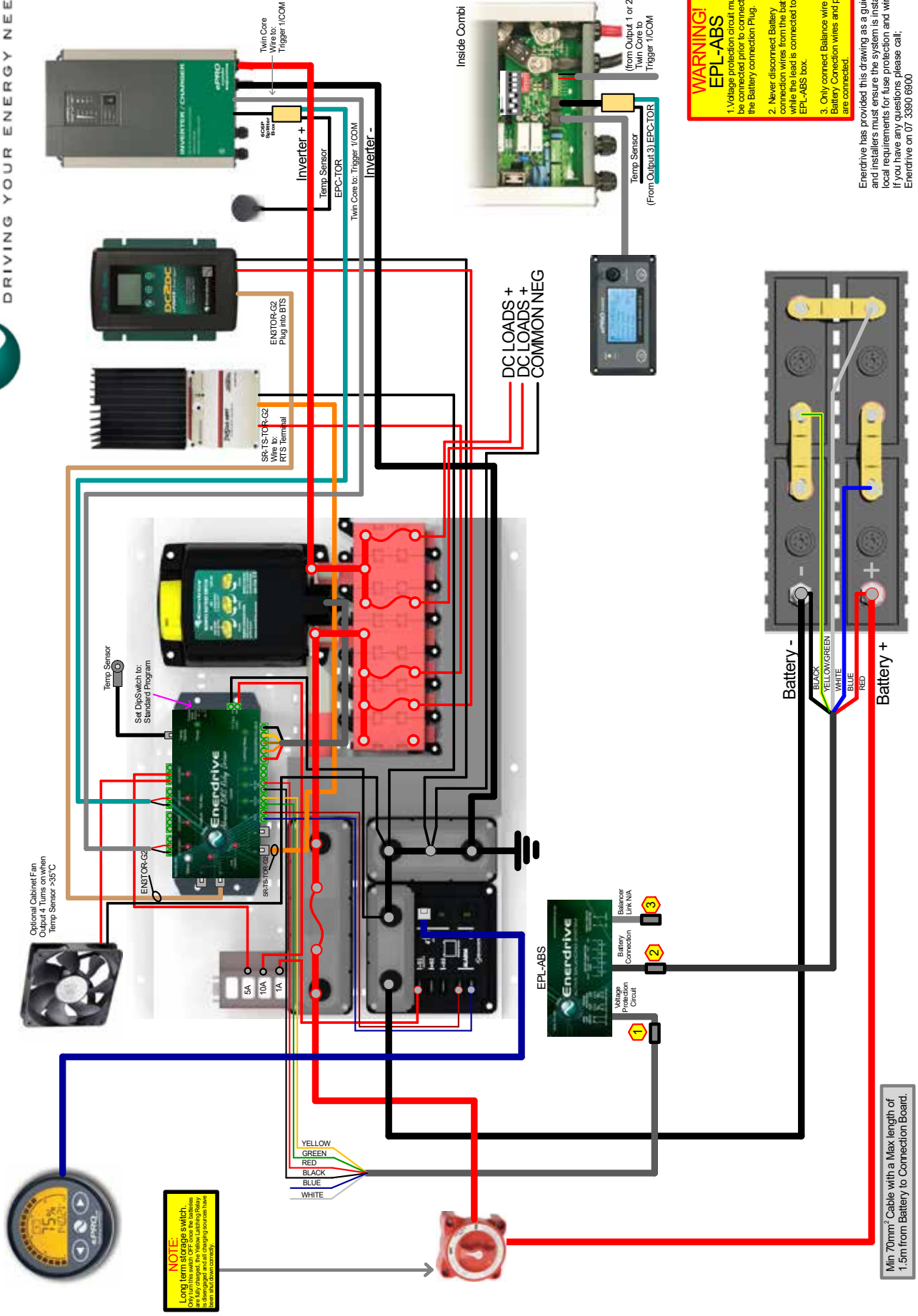

WARNING!
EPL-ABS

1. Voltage protection circuit must be connected prior to connecting the Battery connection plug.
2. Never disconnect Battery connection wires from the battery while the lead is connected to the EPL-ABS box.
3. Only connect Balance wire once Battery Connection wires and plugs are connected.

Enerdrive has provided this drawing as a guide only and installers must ensure the system is installed to the local requirements for fuse protection and wire sizing. If you have any questions please call.
Enerdrive on 07 3390 6800

Min 70mm² Cable with a Max length of 1.5m from Battery to Connection Board.

Lithium Setup - ePRO 3000 Single 12v - 2018-G2

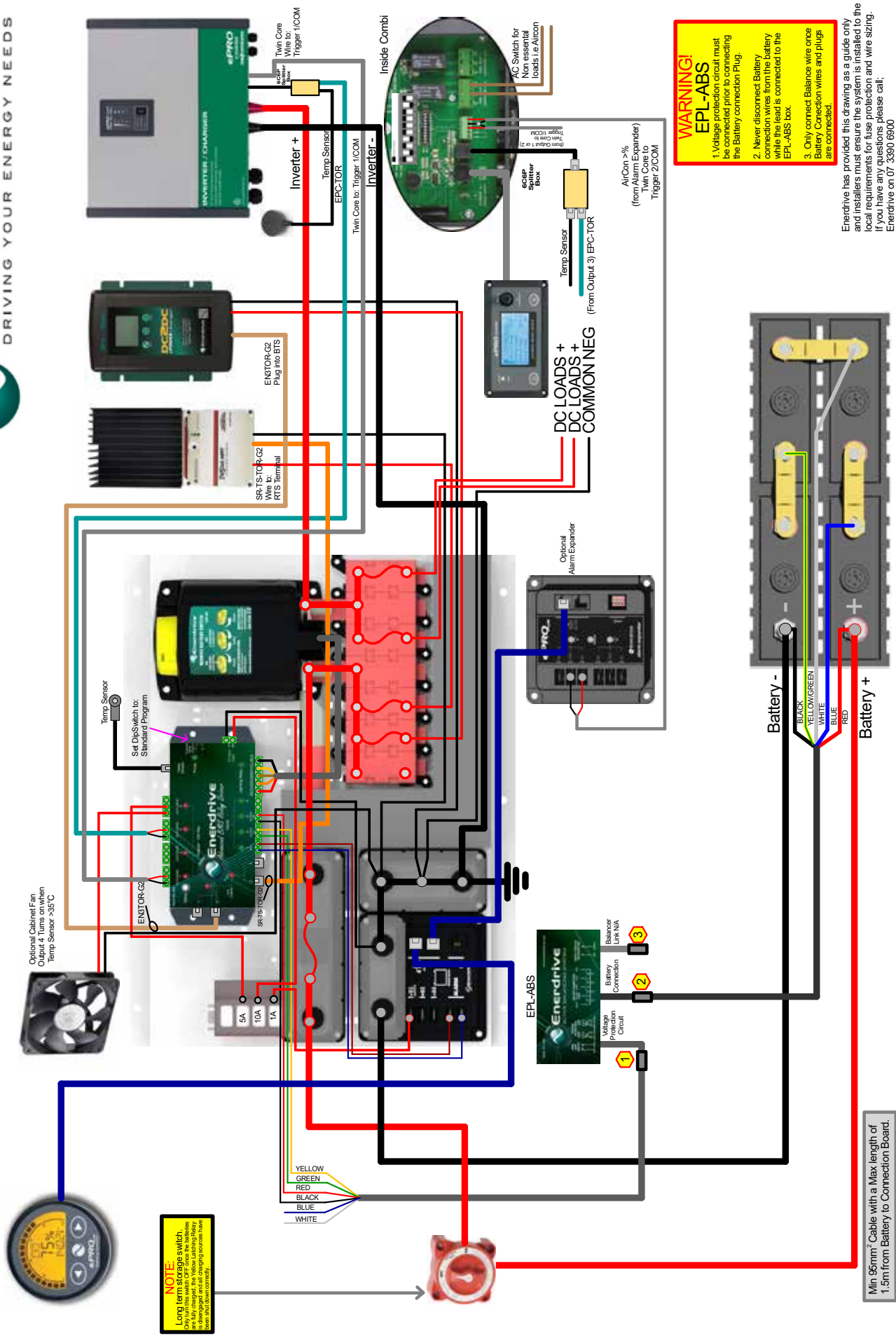

WARNING!
EPL-ABS
 1. Voltage protection circuit must be connected prior to connecting the Battery connection Plug.
 2. Never disconnect Battery connection wires from the battery while the lead is connected to the EPL-ABS box.
 3. Only connect Balance wire once Battery Connection wires and plugs are connected.

Enerdrive has provided this drawing as a guide only and installers must ensure the system is installed to the local requirements for fuse protection and wire sizing. If you have any questions please call: Enerdrive on 07 3390 6900

Min 95mm² Cable with a Max length of 1.5m from Battery to Connection Board.

Lithium Setup - ePRO 3000 Dual 12v - 2018-G2

13/12/2018

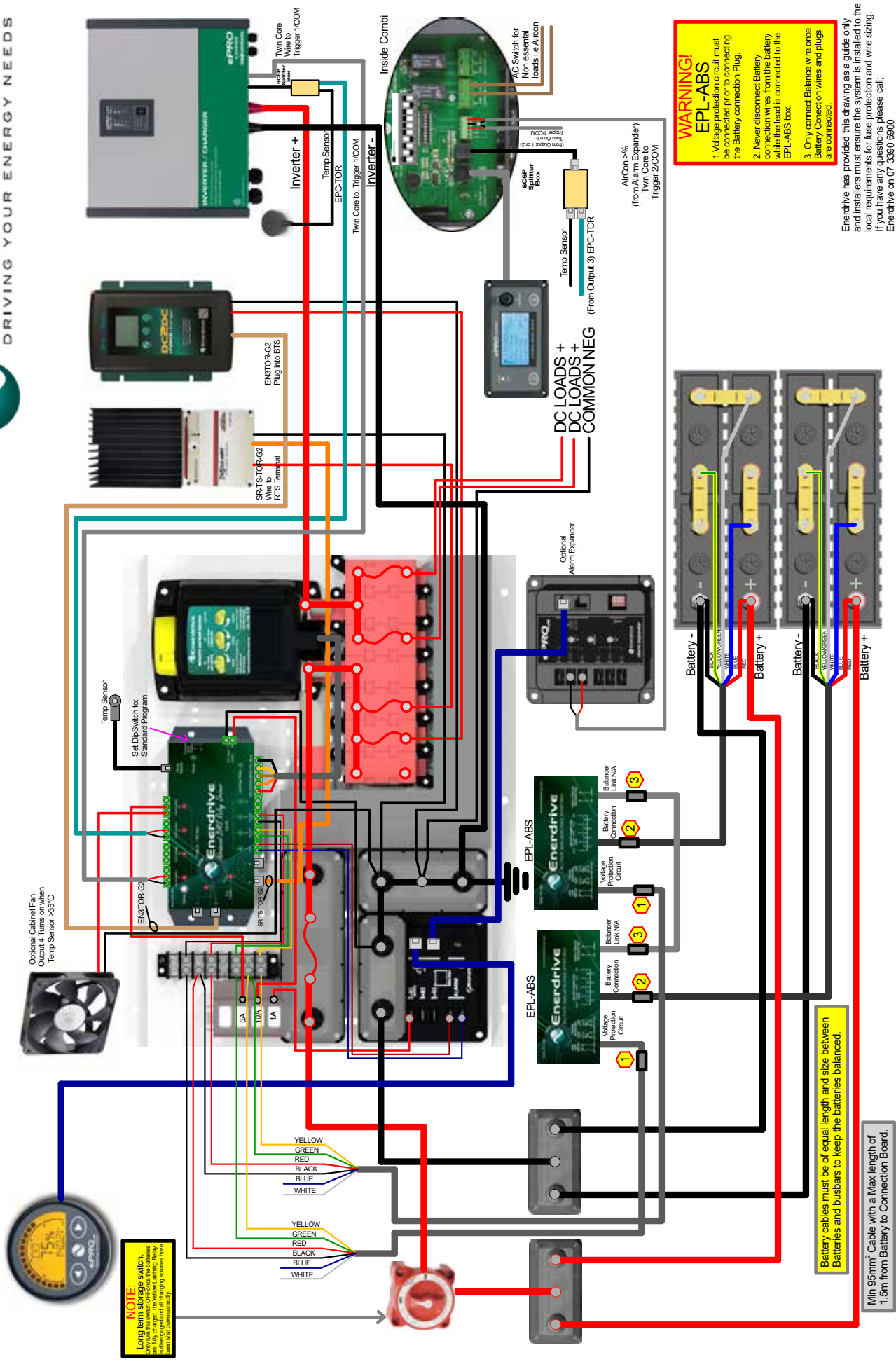

NOTE:
Long term storage switch
Only use this switch if the batteries
will stay charged. The voltage sensing relay
will only disconnect the battery if the voltage
senses too low. Do not connect to
the main shut down connection.

Battery cables must be of equal length and size between
Batteries and busbars to keep the batteries balanced.

Min 95mm² Cable with a Max length of
1.5m from Battery to Connection Board.

WARNING!
EPL-ABS
1. Voltage protection circuit must
be connected prior to connecting
the Battery connection Plug.
2. Never disconnect Battery
connection wires from the battery
while the lead is connected to the
EPL-ABS box.
3. Only connect Balance wire once
Battery Connection wires and plugs
are connected.

Enerdrive has provided this drawing as a guide only
and installers must ensure the system is installed to the
local requirements for fuse protection and wire sizing.
If you have any questions please call:
Enerdrive on 07 3390 6900

Lithium Setup - ePRO 3500 24V - 2018-G2

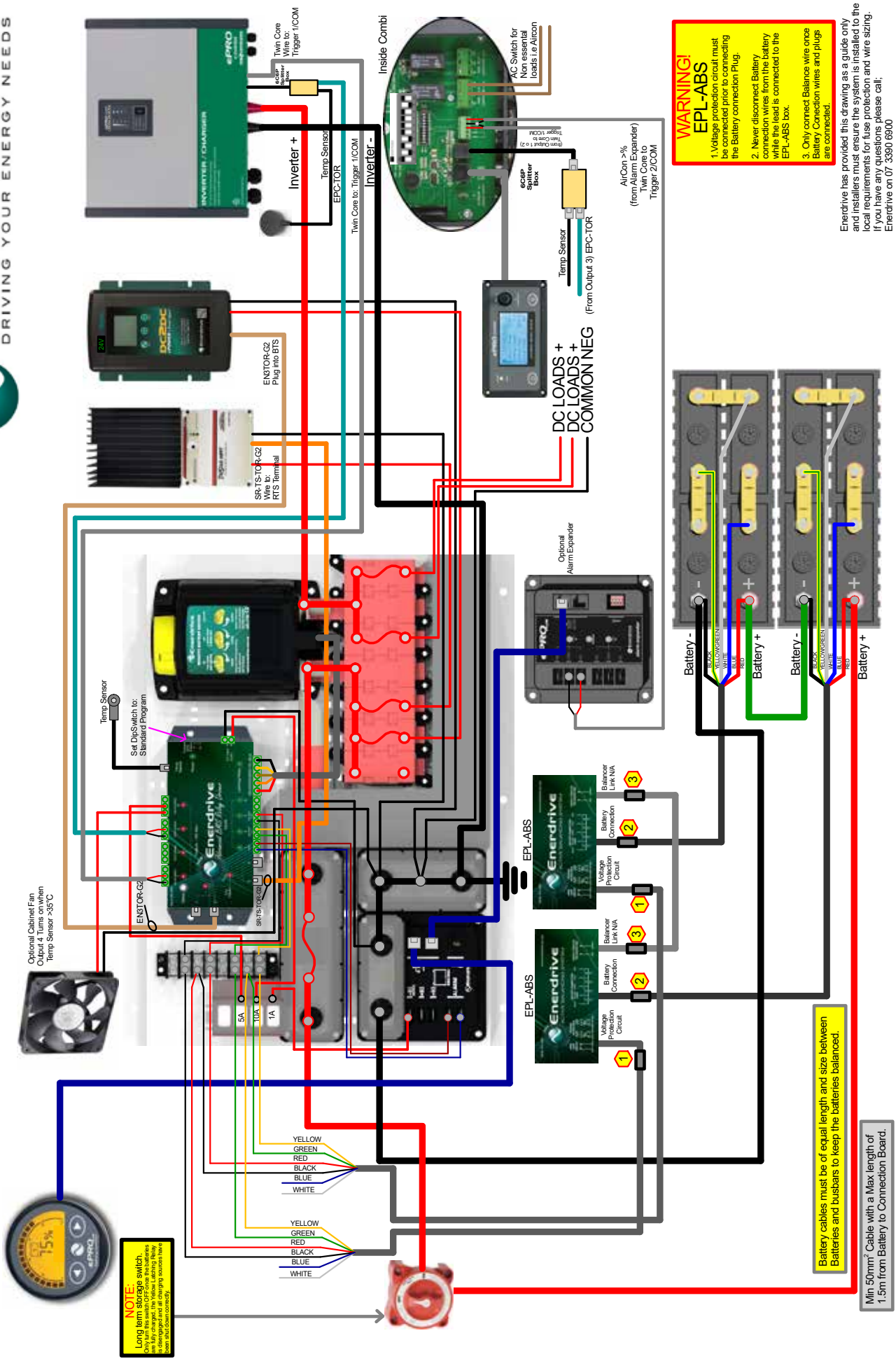

NOTE:
 Long term storage switch.
 When the system is in long term storage, the battery will be fully charged. The Yellow warning light will be illuminated and the charging system will be disabled.

WARNING!
EPL-ABS
 1. Voltage protection circuit must be connected prior to connecting the Battery connection plug.
 2. Never disconnect Battery connection wires from the battery while the lead is connected to the EPL-ABS box.
 3. Only connect Balance wire once Battery Connection wires and plugs are connected.

Enerdrive has provided this drawing as a guide only and installers must ensure the system is installed to the local requirements for fuse protection and wire sizing. If you have any questions please call. Enerdrive on 07 3390 6800

Battery cables must be of equal length and size between Batteries and busbars to keep the batteries balanced.

Min 50mm² Cable with a Max length of 1.5m from Battery to Connection Board.

Lithium Battery Warranty: Two Year Limited Warranty

Our goods come with guarantees that cannot be excluded under the Australian Consumer Law. You are entitled to a replacement or refund for a major failure and for compensation for any other reasonably foreseeable loss or damage. You are also entitled to have the goods repaired or replaced if the goods fail to be of acceptable quality and the failure does not amount to a major failure.

The limited warranty program is the only one that applies to this unit, and it sets forth all the responsibilities of Enerdrive. There is no other warranty, other than those described herein. Any implied warranty of merchantability of fitness for a particular purpose on this unit is limited in duration to the duration of this warranty.

Enerdrive Pty Ltd warrants its Lithium batteries (hereafter referred to as "Battery") to be free of defects in material and workmanship for the following Applicable Warranty Period:

- 1 year for Industrial & Commercial Use
- 2 years for marine pleasure vessel and automotive applications in cycling and non-cycling applications. The battery is warranted, to the original purchaser only, to be free of defects in materials and workmanship for two years from the date of purchase without additional charge. The warranty does not extend to subsequent purchasers or users other than OEM applications.
- An additional 24 months Pro-Rata warranty is included in the battery. The pro-rated price is calculated as a percentage of the current suggested retail price. Pro-Rata warranty applicable to original end user only.

Enerdrive does not warrant the battery for use in any residential system sold with the intent or purpose of a "Tariff Adjustment Program" of any type.

The Enerdrive ePRO Plus battery monitor that is standard with every Lithium-Ion battery kit is pre-programmed by Enerdrive to suit the battery configuration. Any changes that are made to the pre-configuration programming of the ePRO Plus meter will void all warranty of the battery & system.

The warranty does not cover a battery reaching its normal end of life which may occur prior to the warranty period stated above. Depending on the application a battery can reach its normal end of life before the end of the warranty period.

A battery can deliver only a fixed number of usable cycles / amp-hours over its lifetime and is considered to have reached its normal end of life if the application uses up all of these cycles / amp-hours, regardless of the time the battery has been in service. Therefore Enerdrive reserves the right to deny a warranty claim if it determines the battery to be at its normal end of life, even if the claim is lodged within the applicable warranty period.

The Applicable Warranty Period begins from the date of purchase with original receipt, or, if no receipt is available, from Enerdrives invoice / shipping date.

Batteries determined to meet the conditions of this warranty will be replaced free of charge if, at the sole discretion of Enerdrive, adjustment is necessary due to defect in material or workmanship. Batteries for warranty replacement consideration are to be returned to the original supplying distributor/dealer.

Batteries replaced under the warranty provisions will be shipped with a replacement warranty sticker and carry only the remainder of the original Applicable Warranty Period.

The battery is not designed or warranted in the following areas:

- The Battery is NOT to be used in any Aviation aircraft application.
- The Battery is NOT to be used in any lifesaving applications
- The Battery is NOT to be exported to USA/Canada and their territories
- Any residential system sold with the intent or purpose of a "Tariff Adjustment Program" of any type.



PLEASE NOTE

The battery has a self-discharge rate of 5% per month @ 25°C. When storing the battery with the main latching relay disengaged, the ePRO Plus Battery Monitor and Advance Relay Driver will still be powered adding a further drain on the battery.

It is the responsibility of the end user to maintain the battery in a charged state. The battery should not be left for more than 30 days without checking its charge state. Enerdrive recommend that a battery left in a "storage state" should be checked and charged every 30 days to maintain maximum life expectancy of the battery. Failure to follow these requirements will see an early failure of the battery which is not covered under warranty.

General Provisions:

Enerdrives Pty Ltd has no obligation under the limited warranty herein in the event the battery is damaged or destroyed as a result of one or more of the following:

- Wilful abuse, misuse, physical damage, neglect or if the decorative cover has been removed.
- Natural forces such as wind, lightning, hail; damage due to fire, collision, explosion, vandalism, theft, penetration or opening of the battery case in any manner.
- The supplied Enerdrive ePRO Plus battery monitor is pre-programmed by Enerdrive if and any changes are made to the pre-configuration programming of the meter, all warranty is void.
- The battery MUST be installed in an upright position. Installing it upside down or laid on its side will void warranty.
- Overcharging, undercharging, charging or installing in reverse polarity, improper maintenance, allowing the battery to be deeply discharged via a parasitic load or mishandling of the battery such as but not limited to using the terminals for lifting or carrying the battery.
- Charging sources that do not have programmable lithium profile configurations and charge voltage between 13.5V and 14.5V (no lower than 13.0V and no higher than 14.7V) will cause early failure of the battery. Use of such chargers with the battery will also void the battery's warranty. For applications where an alternator is present, the alternator must deliver between 13.5V and 14.2V when measured at the Battery's terminals. Alternators that do not have a regulated charge between 13.5V and 14.2V (no lower than 13.0V and no higher than 14.7V) will cause early failure of the battery. Use of such alternators with the battery will also void the batteries warranty.
- All Enerdrive batteries are supplied with an additional battery installation kit. Failure to install or properly install the battery and its installation kit will void the warranty
- Repair or attempted repair of the battery by anyone other than an authorized Enerdrive representative shall void this warranty.
- Normal or accelerated deterioration in the electrical qualities due to operating or application conditions.
- If the battery is used for an application that requires higher cranking power or a greater reserve rating than the battery is designed to deliver, or the battery capacity is less than the battery capacity specified by the manufacturer, or the battery is otherwise used in applications for which it was not designed.

- Prolonged storage of the battery with either no charge or a parasitic consumption load applied must be offset with a maintenance-float charger of no more than 13.5V or periodic charging or disconnecting the battery to prevent irreversible damage to the battery.
- A battery with an open circuit voltage (OCV) of equal to or less than 10.0V will be deemed as over discharged and void warranty due to misuse and/or neglect.



WARNING

Do NOT use any type of oil, organic solvent, alcohol, detergent, strong acids, strong alkalis, petroleum-based solvent or ammonia solution to clean the battery covers and end plates. These materials may cause permanent damage to the battery covers and end plates and will void the warranty.

Return and/or Repair Policy

If you are experiencing any problems with your unit, please contact our customer service department at support@enerdrive.com.au or Phone 1300 851 535 before returning product to retail store. After speaking to a customer service representative, if products are deemed nonworking or malfunctioning, the product may be returned to the purchasing store within 30 days of original purchase. Any defective unit that is returned to Enerdrive within 30 days of the date of purchase will be replaced free of charge.

If such a unit is returned more than 30 days but less than two years from the purchase date, Enerdrive will repair the unit or, at its option, replace it, free of charge. If the unit is repaired, new or reconditioned replacement parts may be used, at manufacturer's option. A unit may be replaced with a new or reconditioned unit of the same or comparable design. The repaired or replaced unit will then be warranted under these terms for the remainder of the warranty period. The customer is responsible for the shipping charges on all returned items back to Enerdrive.

Limitations

This warranty does not cover damage or defects resulting from normal wear and tear (including chips, scratches, abrasions, discolouration or fading due to usage or exposure to sunlight), accidents, damage during shipping to our service facility, alterations, unauthorized use or repair, neglect, misuse, abuse, failure to follow instructions for care and maintenance, acts of god, fire and flood.

If your problem is not covered by this warranty, contact our Support Team at support@enerdrive.com.au or phone 1300 851 535 for general information if applicable.

To Install & Commission Your Lithium System Please Complete The Following Steps.

FOR USE WITH ALL SYSTEM INSTALLATIONS

1. **Prior to Installation** please make sure you have the correct wiring diagram for your installation and the Main Battery Latching relay is in the OFF Position (Yellow button flush with the top of the switch).
2. Make sure the Dip Switch on the right hand side of the Enerdrive ADV-BMS Relay Driver is set to Program A.
3. Leave the main battery cables disconnected until complete.
4. Connect all DC & AC cables for the system taking note that the polarity is correct, Especially on the BMS Relay Driver.
5. All Positive DC cables for DC LOADS & Inverters are to be on the "SYSTEM" side of the Main Battery Latching Relay.
6. All Positive DC cables from the Enerdrive approved battery chargers & Tristar Solar to be installed on the "BATTERY" side of the Main Battery Latching Relay.
7. Make sure all High & Low protection cables to the Advance BMS Relay Driver from the Battery, Battery Monitor and all charging devices have been installed as per wiring diagram.
8. Make sure all High & Low protection cables to the Advance BMS Relay Driver from both the Battery & Battery Monitor have been installed as per the wiring diagram.
9. Connect DC Cables to the Battery.

LITHIUM COMMISSIONING CHECK SHEET

Refer Fault Finding Codes 1 Thru 11 Refer To Enerdrive Advanced Relay Driver And Charging Sources.

		YES	NO	
1	On activating the Long Term Storage Switch, does the GREEN – DC Power, Input 1,2,3 LEDs on the BMS Relay Driver come on?	<input type="checkbox"/>	<input type="checkbox"/>	see: F1
2	Engage the Main Battery Latching Relay – does the GREEN LED for the "Latching Relay" come on? <i>Please Note: If using an ePRO Combi Inverter/Charger, switch the rocker switch on the front of the unit to the ON position (number 1)</i>	<input type="checkbox"/>	<input type="checkbox"/>	see: F2
3	Remove the connector from Input 1 –the Green LED for Input 1 will now be off and the Status LED will start flashing GREEN?	<input type="checkbox"/>	<input type="checkbox"/>	see: F3
4	After a 40s delay, all TOR Outputs and Outputs 1-3 LEDs will come on (Red) and disengage all connected sources. Within a further 15s, the Main Battery Latching Relay will disengage. Within a further 10s all TOR Outputs and Outputs 1 & 2 LED's will go out turning all connected sources back on? Output 3 LED will still be on (RED) for an additional 30mins to keep a connected ePRO Combi inverter "Locked Out" to allow for the battery to charge before inverter use is possible. If an ePRO Combi is fitted, the "Inverter" LED on the front of the Combi unit should show RED? <i>Please Note: If using an ePRO Combi Inverter/Charger, Output 3 LED will still be on (RED) for an additional 30mins to keep the inverter "Locked Out". The "Inverter" LED on the front of the Combi unit will show RED?</i>	<input type="checkbox"/>	<input type="checkbox"/>	see: F4
5	Replace the connector back into Input 1 –the GREEN LED for Input 1 will turn on. If so, remove the DC Power Input connector on the Advanced Relay Driver and re-insert to reset the Advance Relay Driver to bypass the 30min delay on the inverter lock out to continue the commissioning process and re-engage the Main Battery Latching Relay.	<input type="checkbox"/>	<input type="checkbox"/>	see: F5
6	Input 2 commissioning process is the same as Input 1. Follow steps 3/4/5/ for Input 2 before proceeding to Step 7.	<input type="checkbox"/>	<input type="checkbox"/>	
7	Remove the connector from Input 3 – the Status LED will be now flashing Red and the Green LED for Input 3 will now be off? <i>Please Note: The 10 minute "stop charge" program is now engaged. Questions 8 thru 10 to be completed within the 10min program.</i>	<input type="checkbox"/>	<input type="checkbox"/>	see: F7
8	Did all TOR Outputs and Output LED's 1-2 turn on RED?	<input type="checkbox"/>	<input type="checkbox"/>	see: F8
9	Do all connected charge sources show a Fault Code on their respective screens?			
	<i>If using an Enerdrive ePOWER AC charger – (Fault Code – E06)</i>	<input type="checkbox"/>	<input type="checkbox"/>	see: F9A
	<i>If using an Enerdrive DC2DC charger – (Fault Code – E07)</i>	<input type="checkbox"/>	<input type="checkbox"/>	see: F9B
	<i>If using Morningstar Tristar - Fault Code - LEDs on the front of the controller will be flashing Red/Green</i>	<input type="checkbox"/>	<input type="checkbox"/>	see: F9C
	<i>If using an ePRO Combi Inverter/Charger, did the Combi "Charger" LED Turn RED</i>	<input type="checkbox"/>	<input type="checkbox"/>	see: F9D

Fault Finding.

F1	<p>A: Does the power circuit for the Enerdrive ADV-BMS Relay driver have a 10amp fuse in it?</p> <p>B: Check polarity of the “Power Input” in the Advanced BMS Relay Driver. If it is Reverse Polarity you will need to replace the Advanced Relay Driver as internal damage has occurred.</p>
F2	Check that all wires are connected between the Blue Sea Latching Relay and the Advanced Relay driver if this is correct and LED still does not light up - call Enerdrive.
F3	Make sure the connector is completely removed. If LED does not go out - Call Enerdrive.
F4	<p>A: Check that all wires are connected between the Blue Sea Latching Relay and the Advanced Relay driver.</p> <p>B: Does the Advanced Relay Driver still have power?..Check the fuse.</p> <p>C: If all wiring is ok - Call Enerdrive.</p> <p><i>Please note: If using the Combi Temp Sensor for Cabinet Fan operation from Program Relay 2 as per diagram, please connect this sensor and the EPC-TOR sensor lead into a 6C6P Splitter Box as shown on the wiring diagram.</i></p>
F5	<p>A: Make sure wire is connected correctly.</p> <p>B: If all wiring is ok - Call Enerdrive.</p>
F7	If Input 3 LED is out and the Red LEDs on TOR Outputs 1-4 and Outputs 1-2 are NOT ON - Call Enerdrive.
F8	If there are no Red LEDs turned on - call Enerdrive.
F9	<p>A: Check that the EN3TOR-G2 sensor lead is connected to the Temp Port on the Enerdrive AC Charger and connected to one of the TOR Ports on the Advanced Relay Driver.</p> <p>B: Check that the EN3TOR-G2 sensor lead is connected to the Temp Port on the Enerdrive DC2DC Charger/s and connected to one of the TOR ports on the Advanced Relay Driver.</p> <p>C: Check that the SR-TS-TOR-G2 sensor lead is connected to the Temp Port on the TriStar Controller and connected to a TOR Port on the Advanced Relay Driver.</p> <p>D: Check that there is a twin core cable between the Combi Trigger 1 INPUT & COM contact and into the NO/COM contact on OUTPUT 1 or 2 on the Advanced Relay Driver.</p>
F10	If Input 3 LED does not turn on - call Enerdrive.
F11	If fault codes are still active, you may still be within the 10 minute “Stop Charge” program. Wait a further 10 minutes and if the fault codes don’t disappear - call Enerdrive.
F12	If any of the charge sources are still in fault code, check sensor cable from Advanced Relay Driver to charge source. If connected correctly and fault is still active - call Enerdrive.



ENERDRIVE PTY LTD

P.O. Box 9159, Wynnum Plaza, Queensland, Australia 4178

Ph: 1300 851 535 / Fax: 07 3390 6911

Email: support@enerdrive.com.au

Web: www.enerdrive.com.au