



Gas Safety
Certified

Built-in Hotplate, Ovens, Stoves,
Minigrills,
Hotplate-Sink Combos for
Recreational Vehicles
and Marine.

Models: CU311 - CU311M - CU333 - CU333M - CU335 -
CU335M - CU401 - CU401PE - CU402 - CU402PE
- CU403 - CU403PE - FO311 - MO8103 - MO8123
PI0913 - PI0913A - PI8002 - PI8022 - PI8003 - PI8023
- PI8403 - PI8403GL - PI8423 - PI8423GL - PI8443 -
PI8463 - PI8621A - PI8621S - PI8621R - VN555

**Installation,
use and service manual**

CONTENTS

1	GENERAL INFORMATION	3
1.1	Symbols used in this manual	3
1.2	Using and keeping the manual	3
2.	WARNINGS	4
3.	USE	5
3.1	Precautions	5
3.2	Control panel	5
3.3	Hotplate	6
3.3.1	Selecting the burner	6
3.3.2	Electronic ignition hotplate (depending on model)	7
3.3.3	Manual ignition hotplate	7
3.3.4	Hotplate flame regulation	7
3.4	Oven	7
3.4.1	Electronic ignition oven	8
3.4.2	Manual ignition oven	8
3.4.3	Oven flame regulation with thermostat	8
3.5	Grill	8
3.5.1	Electronic ignition grill	9
3.5.2	Manual ignition grill	9
3.5.3	Flame regulation grill	9
3.6	Electric hotplate (depending on model)	10
3.7	Spit (depending on model)	10

3.8 Turntable (depending on model)10

3.9 Cleaning10

3.10 Abnormal Operation11

4. INSTALLATION 12

4.1 Dimensions of the appliance12

4.2 Fitting cavity12

4.3 Gas connection12

4.4 Electric connection14

4.5 Fixture15

4.6 Testing (before leaving)15

4.6.1 Test point16

4.7 Duplicate data16

plate.....16

5 SERVICING 17

FIGURES AND TECHNICAL DRAWINGS19-32

WHO TO CONTACT 36

1 GENERAL INFORMATION

1.1 Symbols used in this manual

Below are shown the various symbols used in the manual to highlight particularly important information. The safety symbols draw attention to potential hazards for personal safety.

Absolutely respect all safety messages by following these symbols.



WARNING

WARNING

Risk of injury or death.



CAUTION

CAUTION

To avoid possible injuries and/or malfunctions.

1.2 Using and keeping the manual



WARNING

WARNING

Always read the instructions provided in full before installing and using this appliance.

The aim of this manual is to supply all the information necessary to ensure that, as well as being used correctly, the appliance can be managed in the safest and most autonomous way possible.

Keep this manual and all the attached documentation in good condition, legible and complete in all its parts; it is forbidden to remove, rewrite or modify the pages of the manual and their content in any way.

Keep the documentation near the appliance, in an accessible place known to all users.

The manual must always accompany the appliance even in the event of sale and must therefore be handed over to the new user.

2. WARNINGS

Do not use or store flammable materials in the appliance storage drawer or near this appliance.

Do not spray aerosols in the vicinity of this appliance while it is in operation.

Do not modify this appliance.

Where this appliance is installed in marine craft or in caravans, it shall NOT be used as a space heater.

This appliance shall be installed only by authorised persons and in accordance with the manufacturer's installation instructions, local gas fitting regulations, municipal building codes, electrical wiring regulations, AS 5601-2004 - *Gas Installations* and any other statutory regulations.

This appliance must be used only in a well ventilated environment. Do not obstruct the flow of combustion and ventilation air.

This appliance is designed and manufactured for cooking food only. Any other use is considered improper and incorrect creating hazardous conditions. The manufacturer declines all responsibility for damage to things or injuries to persons caused by incorrect installation and / or incorrect and improper use.

If the appliance is to be left unused for any length of time, it is recommended that the gas supply be turned off at the cylinder or main supply valve feeding the appliance.

3. USE

3.1 Precautions



CAUTION

This appliance must only be used by responsible adults. During use and immediately after use the burner and other accessible parts may be hot; do not touch these parts

CAUTION and always keep children at a safe distance. After using the appliance ensure the knob/knobs are off.

After use always shut off the gas supply at the main gas tap.



WARNING

This appliance must not be used by persons (including children) who suffer from psychological and motor related disorders or who are not familiar with or who have no

WARNING experience with the appliance unless under supervision or are being instructed on how to use the appliance by the person responsible for their safety. Children must always be supervised to prevent them from playing with the appliance.



WARNING

The use of gas appliances generates heat and moisture in the immediate area. Always ensure a good ventilation in the cooking area: keep all air vents open for natural ventilation or install an extractor fan (cookerhood).



WARNING

An intense and prolonged use of the appliance may require additional ventilation, for example opening a window, or increasing the power of any mechanical extraction system.



CAUTION

Before cooking with the oven and grill for the first time turn on the oven or grill at high flame and leave the oven on for at least 30 minutes and the grill for 15-20 CAUTION minutes.

Before opening the glass cover of the hotplate, remove any liquids that may have spilled.





WARNING

This warning is affixed in a visible location on the hotplate glass lid. Glass hotplate lids may shatter when heated. Always raise the lid before igniting a burner/s (hotplate, oven and grill) and turn off all burners (hotplate, oven and grill) and let them cool down before lowering the hotplate glass lid.

3.2 Control panel

The following symbols identify which knob corresponds to which burner. **NOTE:**





Different models could have similar knobs and symbols.

- burner knob.  This symbol is positioned near the burner knobs on the hotplate. The black dot indicates the position of the burner on the hotplate.
- knob.  This symbol is positioned near the oven burner knob.
- knob.  This symbol is positioned near the grill burner knob.

This symbol is positioned near the grill burner knob.

The following symbols are for burner flame regulation and correspond to the position of the knob. **NOTE:**

Different models could have similar knobs and symbols.

-  Gas off
-  High flame
-  Low flame
- 0** Electric hotplate off
- 1 - 2 - 3 - 4 - 5 - 6** Oven and/or electric hotplate temperature
-  Grill

OTHER SYMBOLS



Electronic ignition pushbutton



This symbol is affixed in a clearly visible position near the oven control knob for all models fitted with electronic ignition which is activated by maintaining the control knob pressed.

CAUTION



Light switch



Spit switch



Turntable switch

In CU4... models it is also present as a turntable and light.

3.3 Hotplate

3.3.1 Selecting the burner



WARNING

The flame must never extend beyond the edge of the pan. Centre the pan over the burner ensuring stability on the pan support.

WARNING

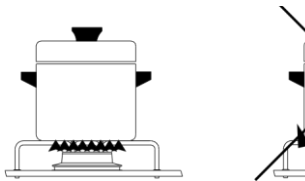

Burner	Pan diameter	
	Min	Max
Auxiliary Ø 47 mm	6 cm	16 cm
Semi-rapid Ø 62 mm	16 cm	22 cm
Rapid Ø 77 mm	16 cm	22 cm

3.3.2 Electronic ignition hotplate (depending on model)



WARNING

Make sure there are no pans or any other objects on the burners when igniting.

WARNING

To ignite the burner, gently push in and turn the control knob to position HIGH FLAME and, keeping the knob pushed in, at the same time press the electronic ignition pushbutton. Once the burner is lit, keep the knob pushed in for a few seconds to ensure the flame remains lit.



CAUTION

If the burner does not ignite immediately repeat ignition after having followed each step below:

CAUTION • Turn the knob to "Low flame"

- Proceed with manual ignition
- Check there is sufficient gas in the gas bottle.

If the appliance still does not ignite shut off the gas supply at the main gas tap and contact your local dealer.

3.3.3 Manual ignition hotplate

Manual ignition when the appliance is not fitted with the electronic ignition feature or in the event of failure in the electronic ignition.



WARNING

Make sure there are no pans or any other objects on the burners when igniting.

WARNING

To ignite the burner, gently push in and turn the control knob to position HIGH FLAME and, keeping the knob pushed in, at the same time light the burner with a match or gas lighter. Once the burner is lit, keep the knob pushed in for a few seconds to ensure the flame remains lit.



CAUTION

If the burner does not ignite immediately, check there is sufficient gas in the gas bottle.

CAUTION If the appliance still does not ignite, shut off the gas supply at the main gas tap and contact your local dealer.

3.3.4 Hotplate flame regulation

To regulate the flame turn the knob to the desired cooking flame.

3.4 Oven



CAUTION

The oven burner must be ignited only with the oven door fully open.

CAUTION



WARNING

The wire shelf, drip tray and oven dish when in the oven must be positioned so as to avoid coming into contact with the flames.

WARNING If the burner flame goes out accidentally, turn off the gas knob and wait one minute before re-igniting.

3.4.1 Electronic ignition oven

To ignite the burner, push in and turn the control knob to a position from 1 to 6 and, keeping the knob pushed in, at the same time press the electronic ignition pushbutton (for models that have  affixed to the oven door the electronic ignition button is not visible and is activated by pressing the gas knob down). Once the burner is lit, keep the knob pushed in for a few seconds to ensure the flame remains lit.



CAUTION

If the burner does not ignite immediately, repeat ignition after having followed each step below:

CAUTION • proceed with manual ignition

- check there is sufficient gas in the gas bottle.

If the appliance still does not ignite, shut off the gas supply at the main gas tap and contact your local dealer.

3.4.2 Manual ignition oven

Manual ignition when the appliance is not fitted with the electronic ignition feature or in the event of failure in the electronic ignition.

To ignite the burner, gently push in and turn the control knob to a position from 1 to 6 and, keeping the knob pushed in, at the same time light the burner with a match or gas lighter. Once the burner is lit, keep the knob pushed in for a few seconds to ensure the flame remains lit.



CAUTION

If the burner does not ignite immediately, check there is sufficient gas in the gas bottle.

CAUTION If the appliance still does not ignite, shut off the gas supply at the main gas tap and contact your local dealer.

3.4.3 Oven flame regulation with thermostat

Positions	1	2	3	4	5	6
Temperature	130 °C	160 °C	180 °C	200 °C	220 °C	240 °C

When the oven burner is ignited the flame remains at high flame in all knob positions. When the oven reaches the set temperature the flame automatically goes down to low flame.

3.5 Grill



CAUTION

The grill burner must be ignited only with the door fully open.

CAUTION



WARNING

If the burner does not ignite immediately, release the knob, wait for at least 10 seconds and ignite again.

WARNING As accessible parts may be very hot when using the grill, keep children at a safe distance from grill.

When using the grill the door must be kept open and with the heat guard fully extracted (FIG. 1 – PG. 19).

Never use the grill for more than 25 minutes. The grill cannot be used as an oven.

If the burner flame goes out accidentally, turn off the gas knob and wait one minute before re-igniting.

3.5.1 Electronic ignition grill



WARNING

Do not ignite the grill burner with the door closed.

WARNING

To ignite the burner, gently push in and turn the control knob to position GRILL or HIGH FLAME and, keeping the knob pushed in, at the same time press the electronic ignition button (for models with the  symbol affixed to the door, the ignition button is not visible and is activated by pressing the knob down). Once the burner is lit, keep the knob pushed in for a few seconds to ensure the flame remains lit.



CAUTION

If the burner does not ignite immediately, repeat ignition after having followed each step below:

CAUTION • proceed with manual ignition

- **check there is sufficient gas in the gas bottle.**

If the appliance still does not ignite, shut off the gas supply at the main gas tap and contact your local dealer.

3.5.2 Manual ignition grill

Manual ignition when the appliance is not fitted with the electronic ignition feature or in the event of failure in the electronic ignition.

To ignite the burner, gently push in and turn the control knob to position GRILL or HIGH FLAME and, keeping the knob pushed in, at the same time light the burner with a match or gas lighter. Once the burner is lit, keep the knob pushed in for a few seconds to ensure the flame remains lit.



CAUTION

If the burner does not ignite immediately, check there is sufficient gas in the gas bottle.

CAUTION If the appliance still does not ignite, shut off the gas supply at the main gas tap and contact your local dealer.

3.5.3 Flame regulation grill

For models CU311 - CU311M - CU333 - CU333M - CU335 - CU335M - FO311: the grill is to be used only at its maximum capacity.

For all other models:

to regulate flame, turn the knob to the desired cooking flame.

3.6 Electric hotplate (depending on model)



CAUTION

Before turning on the electric hotplate (or if the hotplate has remained unused for a long time) it is necessary to eliminate any moisture by turning on the hotplate and **CAUTION leaving it on for 30 minutes with the corresponding knob in position 1.**

Use pans with flat bottoms and with diameters no less than the diameter of the hotplate.

Dry the bottom of the pan before placing it on top of the hotplate.

When using the hotplate do not leave the appliance unattended and make sure children are nowhere near the appliance.

The electric hotplate is controlled by a 7-position knob: position off is 0 (zero) whereas positions 1 to 6 are for regulating the hotplate. Positions 1 to 6 correspond to an increase in temperature of the hotplate. There is a red LED positioned next to the knob which lights up when the hotplate is on.

3.7 Spit (depending on model)

Ignite the oven as described in the chapter 3.4 Oven. Turn the gas knob to the required position. Insert the drip tray with the spit already installed as illustrated in FIG. 2 - PG. 19. Press the spit button to turn on the spit motor.

3.8 Turntable (depending on model)

Ignite the oven burner as indicated in chapter 3.4 Oven. Insert the turntable as indicated in FIG. 3 - PG. 19 Press the switch to operate the turntable motor.

3.9 Cleaning

No regular maintenance is required except cleaning.



WARNING

Some cooking operations generate a considerable amount of grease. This, combined with spillage, can become a hazard if allowed to accumulate on the appliance through ^{WARNING} lack of cleaning.



CAUTION

Keep the appliance clean and in good working condition. To clean below the hotplate burners, remove the burner cap screws using a suitable screwdriver. Once the ^{CAUTION} screws are removed, the burner cap and burner head can be removed to provide access below the burner. Once cleaned, ensure the burner head and burner cap are refitted. It is recommended to have it serviced annually by authorized personnel.



WARNING

WARNING

Before cleaning the appliance always turn it off and disconnect from power supply and wait until it has cooled down.



CAUTION

CAUTION

Hot surfaces may be damaged on contact with cold water or with a wet cloth. Do not use abrasive, corrosive or chlorine-based products, pot scourers or steel wool. Do ^{CAUTION} not leave acid or alkaline substances (vinegar, salt, lemon juice, etc.) on the surfaces of the appliance. Stainless steel surfaces and enamelled parts must be washed with water and neutral soap or detergent, rinsed and dried. Use clean sponges and cloths.



WARNING

Never use abrasive and / or coarse cleaning materials or metal brushes to clean the glass oven door as these materials scratch the glass surface with the risk of shattering the glass.



WARNING

Never use steam cleaners to clean the appliance.



CAUTION

Do not leave heavy spillover to bake on, as this will make cleaning more difficult.



CAUTION

The trivet (pan support) can be removed by carefully pulling the extended pins evenly out of the plastic locaters in the hotplate. When replacing the trivet, ensure ^{CAUTION} that the plastic guides are not damaged.

3.10 Abnormal Operation

Gas valves, which are difficult to turn are considered to be abnormal operation and may require servicing. In case the appliance fails to operate correctly, contact the authorised service provider in your area.

4.1 Dimensions of the appliance

The overall dimensions are illustrated in FIG. 5 - PG. 21 with the cavity diagrams.

The overall dimensions include the trivet (pan support), control knobs, handles and gas connection.

4.2 Fitting cavity



WARNING

The appliance must fitted at an appropriate and safe distance from flammable materials.



WARNING

For the CU..., FO... and VN555 models, the cavity that the appliance is built into must be completely sealed off. It is important that the inside panels of the cavity are ^{WARNING} completely sealed and do not communicate with adjoining cavities or the outside. The openings in the cavity that allow access to the gas and electric connections should be sealed with rubber or foam.

The gas connection (1/4 BSPT female) is located at the rear for models CU..., FO... and for model VN555, whereas it is on the bottom for models PI... and MO...

The electric connection is located at the rear for models CU..., FO... and for model VN555, whereas it is on the bottom for models PI... and MO... (consult chapter 4.4 Electric connection to see whether the appliance needs this connection).

Minimum allowable distances from walls (FIG. 4 - PG. 20)

200 mm	From the external edge of the burner head nearest to a side and / or back wall.
600 mm	Between the top part of the burners and cabinets and / or shelves fitted above the hotplate.

100 mm	From the sides of the appliance and vertical walls.
170 mm	From the top side to the cabinets and / or shelves fitted above the appliance.

Dimensions of fitting cavity

Cut out a hole in the cabinet as illustrated in FIG. 5 - PG. 21 size will depend on appliance model. The cabinet must be appropriately constructed and aligned horizontally with the worktop and with the unit. The cabinet aperture must be perfectly squared and aligned. If there are apertures for cabinet ventilation, prevent flammable materials from entering these.

4.3 Gas connection



WARNING

This appliance shall be installed only by authorised persons and in accordance with the manufacturer's installation instructions, local gas fitting regulations, municipal

WARNING building codes, electrical wiring regulations, AS 5601-2004 - *Gas Installations* and any other statutory regulations.



WARNING

This appliance is not connected to a flue terminal which discharges the product of combustion to the outside. Any enclosed space in which the appliance is installed

WARNING must therefore be provided with permanent ventilation in accordance with relevant federal and state regulations in force, and the requirements of gas installations with particular attention being paid to the matter of room ventilation.



WARNING

The appliance is not suitable for connection with a hose assembly.

WARNING



WARNING

A manual shut-off valve shall be provided on the inlet connection of the appliance. The valve shall be accessible for operation and firmly fixed.

WARNING

Below are the gas characteristics for which the appliance is set (given also on the appliance data plate). A pressure reducer suitable for the type of gas used must be connected between the gas cylinder and the appliance:

GAS	PRESSURE	OUTPUT OF THE REGULATOR
UNIVERSAL LPG	2,75 kPa	2,5kg/h

NOMINAL GAS CONSUMPTION

Model №	AUXILIARY					SEMI-RAPID					RAPID					TOTAL NOMINAL GAS CONSUMPTION MJ/h
	Ø 47 mm		Ø 62 mm		Ø 77 mm		Grill		Oven		CONSUMPTION					
	№	MJ/h	№	MJ/h	№	MJ/h	№	MJ/h	№	MJ/h	№	MJ/h				
CU311	2	3.8	2	5.9			1	5.2	1	3.8					24.6	
CU311M	2	3.8	2	5.9			1	5.2	1	3.8					24.6	

CU333	1	3.8	1	5.9			1	5.2	1	3.8	14.9
CU333M	1	3.8	1	5.9			1	5.2	1	3.8	14.9
CU335	1	3.8	2	5.9			1	5.2	1	3.8	20.8
CU335M	1	3.8	2	5.9			1	5.2	1	3.8	20.8
CU401	1	3.8	3	5.9			1	5.2	1	3.8	30.5
CU401PE	1	3.8	2	5.9			1	5.2	1	3.8	24.6
CU402	1	3.8	3	5.9			1	5.2			26.7
CU402PE	1	3.8	2	5.9			1	5.2			20.8
CU403	1	3.8	3	5.9							21.5
CU403PE	1	3.8	2	5.9							15.6
FO311							1	5.2	1	3.8	5.2
MO8103	2	3.8	1	5.9							13.5
MO8123	2	3.8	1	5.9							13.5
PI0913	2	3.8	1	5.9							13.5
PI0913A	2	3.8	1	5.9							13.5
PI8002	1	3.8	1	5.9							9.7
PI8022	1	3.8	1	5.9							9.7
PI8003	1	3.8	2	5.9							15.6
PI8023	1	3.8	2	5.9							15.6
PI8403	1	3.8	2	5.9							15.6
PI8403GL	1	3.8	2	5.9							15.6
PI8423	1	3.8	2	5.9							15.6
PI8423GL	1	3.8	2	5.9							15.6

NOMINAL GAS CONSUMPTION

AUXILIARY SEMI-RAPID RAPID

**TOTAL
NOMINAL GAS**

Ø 47 mm Ø 62 mm Ø 77 mm Grill Oven CONSUMPTION

Model № MJ/h № MJ/h № MJ/h № MJ/h № MJ/h

MJ/h

PI8443	1	3.8	2	5.9							15.6
--------	---	-----	---	-----	--	--	--	--	--	--	------

PI8463	1	3.8	2	5.9							15.6
PI8621A	1	3.8									3.8
PI8621R					1	7.2					7.2
PI8621S			1	5.9							5.9
VN555							1	5.2			5.2

BURNER	INJECTOR ORIFICE (mm)	STAMPED №
AUXILIARY (Ø 47mm)	0.57	57
SEMI-RAPID (Ø 62mm)	0.72	72
RAPID (Ø 77mm)	0.80	80
GRILL	0.67	67
OVEN	0.57	57

The connection of the gas pipe to the appliance (1/4 BSPT female) must be made with a rigid metal pipe. The pipe work and fittings shall be free from defects and of an approved type.

Once installed, the installation must be checked for leaks by means of an approved testing method.

Do not use a solution of soap and water.



WARNING
Never use a naked flame to check for gas leaks.

WARNING

4.4 Electric connection

Low voltage 12 V ===

This chapter concerns only models marked 12 V === on the appliance data plate.



CAUTION
This appliance must be connected to a 12 V === source. The circuit must be protected by a fuse of no more than 3 Ampere.

CAUTION **Ensure that the polarity of the connection is correct!**



WARNING
Absolutely do not connect the appliance to the mains voltage (230 V~), this would destroy the components and cause a hazard for the user.

WARNING

To connect the appliance use a 1.5 mm² double red and black wire and wire to the terminal junction box located at the rear of the appliance with the wording “+12 V === – “. The red terminal is the positive pole and the black terminal is the negative pole.

High voltage 230-240 V~

This chapter refers only to the models listed in the table below.

Model	Nominal voltage	Nominal power
CU401PE - CU402PE - CU403PE	230-240V~	800 W

In these models there is an electric plate in the hotplate.



WARNING

When connecting direct to the mains supply, it is necessary to install a circuit breaker which allows for disconnecting and isolating the appliance from the mains WARNING in the event of overvoltage III conforming to installation regulations.

The supply cord must be positioned in such a way that it never reaches a temperature of 75 °C above ambient in any point.

The plug must be easy to access after installation.

Always disconnect electrical power before working on or servicing the appliance.

For connecting to the mains power supply use a socket.

If the supply cord (H05RR-F 3x0,75mm²) is damaged, it must be replaced by the manufacturer or its service agent or a similarly qualified person in order to avoid a hazard.

4.5 Fixture



CAUTION

This appliance is to be fixed and secured to the cabinet as described in FIG. 6 – PG. 26.

CAUTION

4.6 Testing (before leaving)

Ignite all burners both individually and concurrently to ensure correct operation of gas valves, burners and ignition. Turn gas taps to low flame position and observe stability of the flame for each burner individually and concurrently. Ensure correct operation of the flame failure protection.

Depending on the type of gas used, the appearance of the flame is as follows:

Propane: flame with blue centre and well-defined contour.

Butane: flame with light yellow tips when igniting the burner, gradually intensifying as the burner heats.



CAUTION

In case the appliance fails to operate correctly after all checks have been carried out, shut off the gas supply at the main gas tap and refer to the authorized service CAUTION provider in your area.

When satisfied with the appliance, please instruct the user on the correct method of operation.

4.6.1 Test point

For models PI... MO... CU...

The test point is supplied loose with the appliance (see picture in FIG. 7 - PG. 31). Remove one burner head, the injector and screw in test point fitting. The pressure is measured with the relevant burner gas valve on high flame and with an inlet pressure of 2.75 kPa.

For models FO...

The test point is fitted on the main gas pipe. Remove the front plastic plaque (see picture in FIG. 8 - PG. 31) and remove the screw. The pressure is measured with an inlet pressure of 2.75 kPa.

For models VN555

The test point is fitted on the main gas pipe. Remove the screw. The pressure is measured with an inlet pressure of 2.75 kPa.

4.7 Duplicate data plate

After installation, the data plate may be consulted by opening the door of the oven or of the grill compartments, or on the back of the instructions manual.

The date of manufacture can be deduced from the serial number: the 2nd and the 3rd figure indicate the year, the 4th and the 5th figure the week. See the example below.



5 SERVICING



WARNING

The servicing shall be carried out only by authorized personnel.

WARNING



WARNING

Do not modify this appliance.

WARNING



WARNING

Before any servicing intervention shut off gas supply, disconnect all the electrical power supplies and remove the appliance.

WARNING

Hotplate: burners, injectors, thermocouples and ceramic igniters 1.

Remove trivet (pan support) by pulling up from hotplate.

2. Remove screws from appropriate burner head disk. Remove head disk.
3. Remove burner by lifting straight up, taking care not to damage the thermocouple and ceramic igniter.
4. Using a 7mm spanner, unscrew the injector. When removing and fitting the injector, the injector holder must be held in place with the aid of a tool (FIG. 9 - PG. 32)
5. Remove retaining washer from thermocouple head.
6. Disconnect appropriate thermocouple lead from gas cock.
7. Remove the thermocouple.
8. Remove retaining spring from ceramic igniter head.
9. Disconnect appropriate ceramic igniter lead from electronic igniter unit.
10. Remove the ceramic igniter.

11. Replace/ refit in reverse procedure.

Oven: injector, burner, thermocouple and ceramic igniter

1. From right hand side of appliance, remove spring from the oven burner inlet.
2. Using a 7mm spanner, unscrew the injector. When removing and fitting the injector, the injector holder must be held in place with the aid of tool (FIG. 9 - PG. 32).
3. Remove lower heat shield at rear and tilt appliance forward.
4. Unscrew the oven burner mounts and lower burner.
5. Remove retaining nut from thermocouple head.
6. Disconnect the oven thermocouple lead from the gas cock.
7. Remove the thermocouple.
8. Remove retaining screw from ceramic igniter support.
9. Disconnect ceramic igniter lead from appropriate electronic igniter unit.
10. Remove the ceramic igniter.
11. Replace/ refit in reverse procedure.

Grill: injector, thermocouple, ceramic igniter and burner

1. From right hand side of appliance, remove spring from the grill burner inlet.
2. Using a 7mm spanner, unscrew the injector. When removing and fitting the injector, the injector holder must be held in place with the aid of tool (FIG. 9 - PG. 32)
3. Remove the protection disk (not present in the CU4... models)
4. Remove retaining nut from thermocouple head.
5. Disconnect the grill thermocouple lead from the gas cock
6. Remove the thermocouple.
7. Remove retaining screw from ceramic igniter support.
8. Disconnect ceramic igniter lead from appropriate electronic igniter unit.
9. Remove the ceramic igniter.
10. Remove the grill burner mounting screws (2) from top.
11. Remove the grill burner mounting spacers (only for CU4... models) and lower burner.

Gas cocks

1. Remove the control knob by pulling.
2. Unscrew gas cock retaining nut.
3. From the underside of the appliance, remove the thermocouple lead and the gas pipe from the gas cock.
4. Remove the appropriate gas cock clamp by unscrewing the screws.
5. Remove the gas cock from the manifold.
6. Replace/ refit in reverse procedure.

Oven thermostat

1. Remove the appropriate control knob by pulling.
2. Unscrew gas cock retaining nut.
3. From the underside of the appliance, remove the thermocouple lead and the gas pipe from the thermostat.
4. Remove the thermostat clamp by unscrewing the screws.
5. Remove the thermostat from the manifold.
6. Open oven door and remove the capillary bulb/ phial from its mount.
7. Remove capillary bulb/ phial through access hole.
8. Replace/ refit in reverse procedure.

Igniter unit/s

1. From the rear right-hand side of appliance, remove electrical connectors from igniter unit/s (noting connection locations).
2. Remove the retaining rivets from appropriate igniter unit.
3. Remove the igniter unit.
4. Replace / refit in reverse procedure.

Oven door

1. Open oven door fully.
2. Remove the door hinge screws (2 each) at either side of the bottom of oven compartment.
3. Remove door from appliance.
4. Replace/ refit in reverse procedure.

230-240 V~ WIRING DIAGRAM

Shown below is the wiring diagram for the 230-240 V~ connection for a stove with electric element on the hotplate.

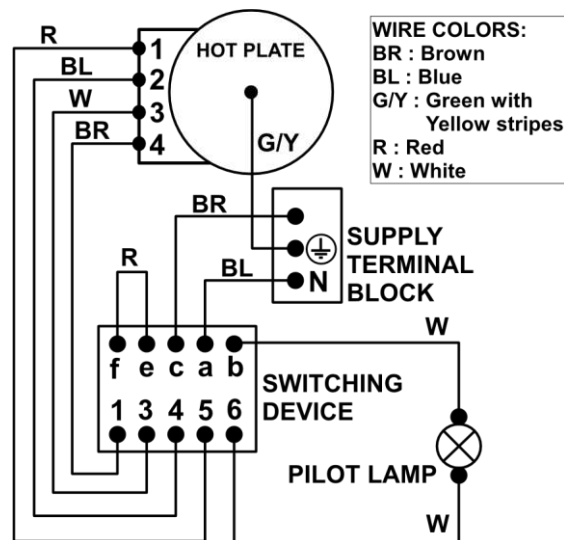

FIGURES AND TECHNICAL DRAWINGS

Figure 1

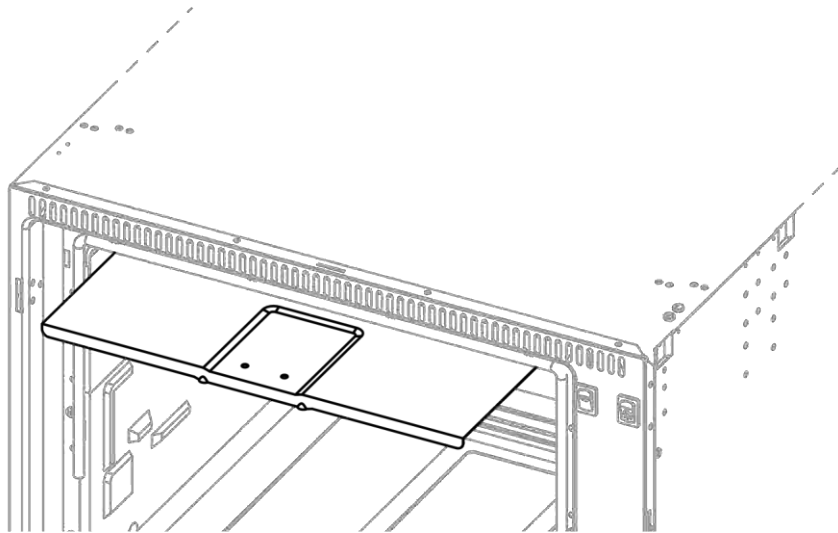

Figure 2

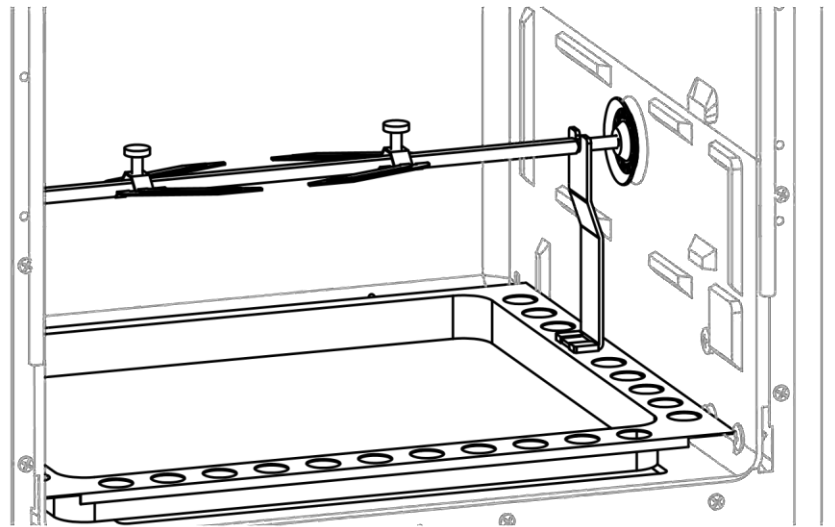

Figure 3

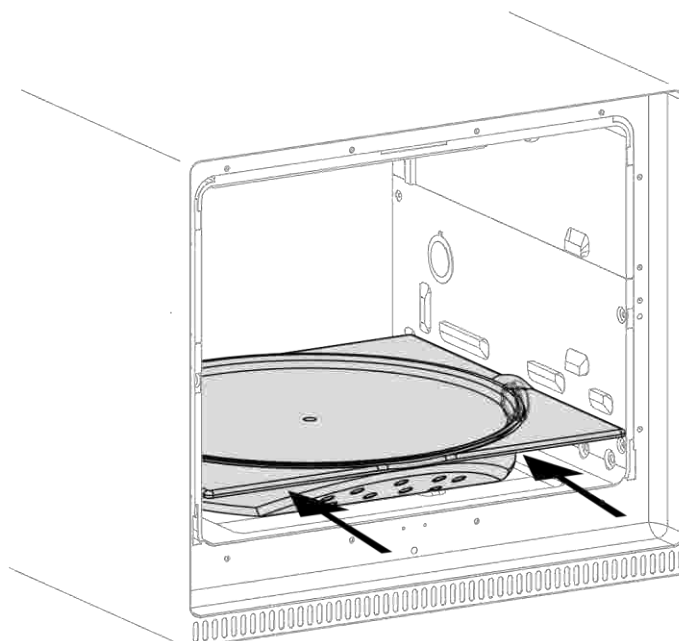
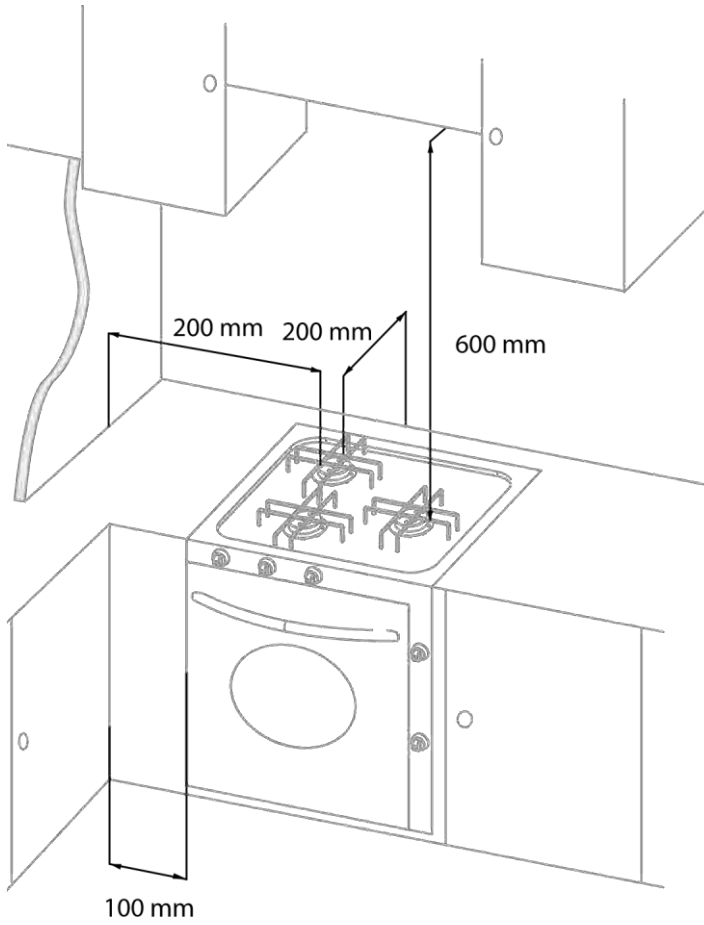
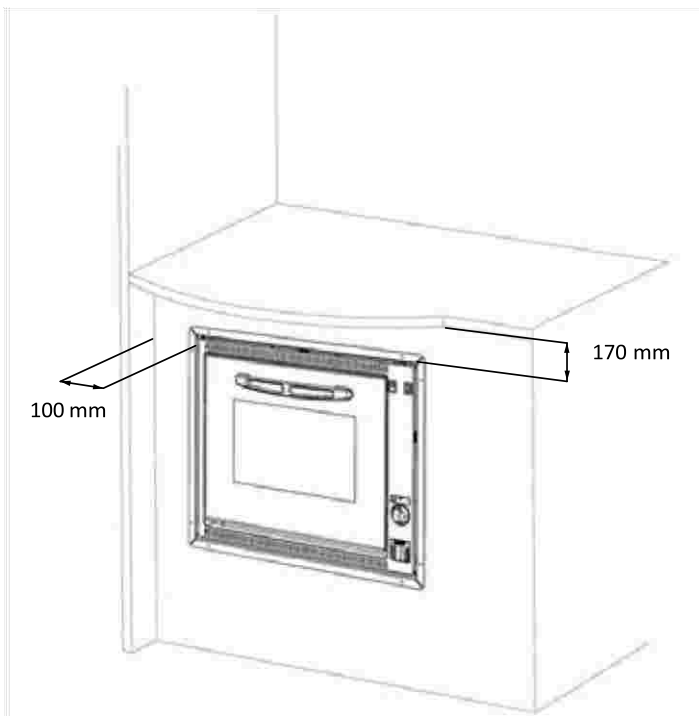

Figure 4



CU311 - CU311M - CU333 - CU333M
 - CU335 - CU335M - CU401 - CU401PE
 - CU402 - CU402PE
 - CU403 - CU403PE - MO8103 -
 MO8123 - PI0913 - PI0913A - PI8002
 - PI8022 - PI8003 - PI8023 - PI8403 -
 PI8403GL - PI8423 - PI8423GL - PI8443
 - PI8463 - PI8621A - PI8621S -
 PI8621R



FO311 - VN555

Figure 5

TECHNICAL DRAWINGS

CU311
CU333
CU335

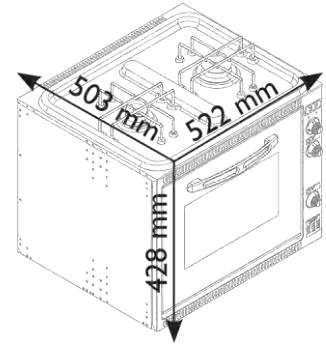

FRONT VIEW

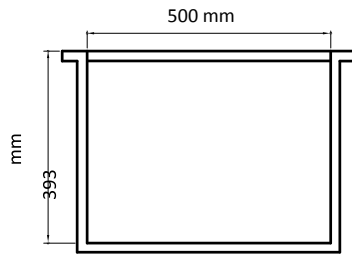

SIDE VIEW

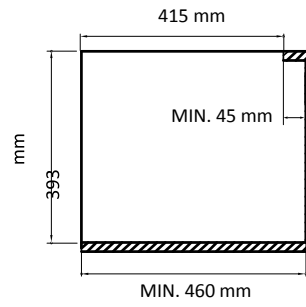

CU311M
CU333M
CU335M

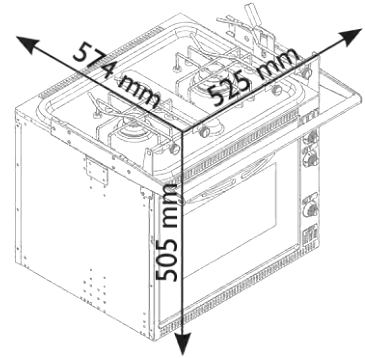

FRONT VIEW

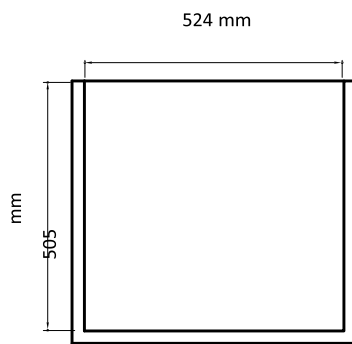

SIDE VIEW

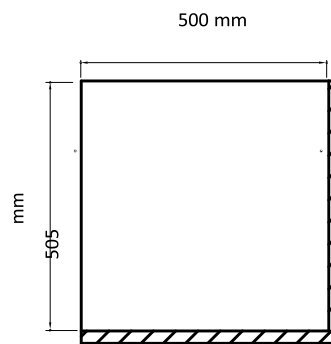

CU401
CU401PE

TOP VIEW

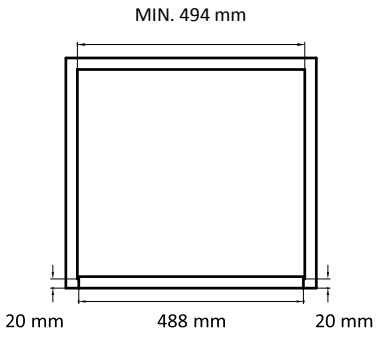

FRONT VIEW

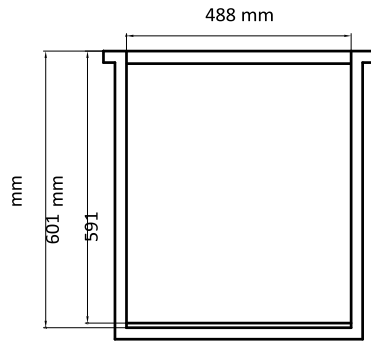

SIDE VIEW

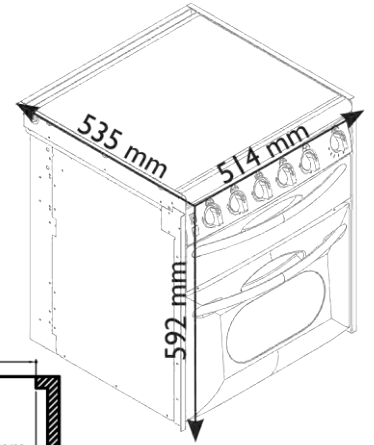
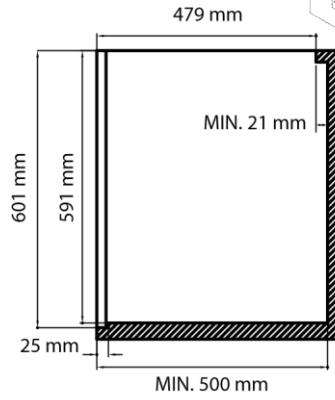

CU402
CU402PE

TOP VIEW

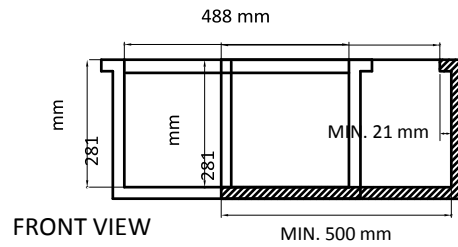
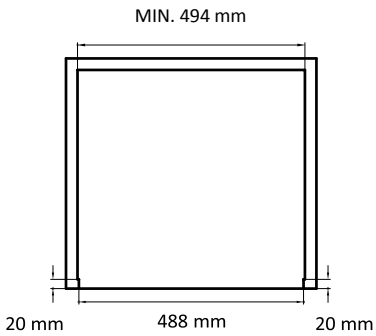

SIDE VIEW

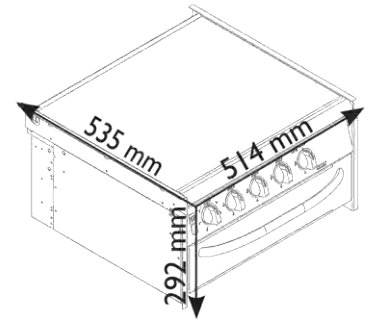

CU403
CU403PE

TOP VIEW

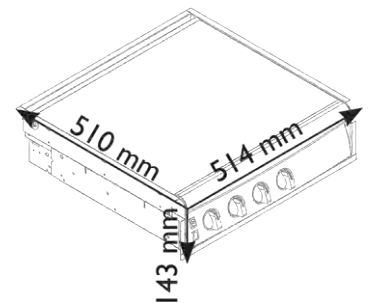

TECHNICAL DRAWINGS

MIN. 494 mm

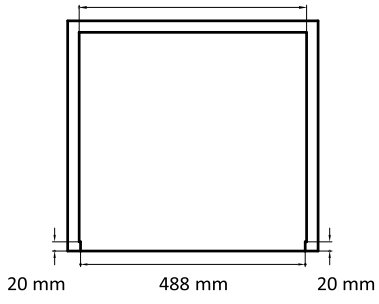

FRONT VIEW

488 mm



SIDE VIEW

479 mm

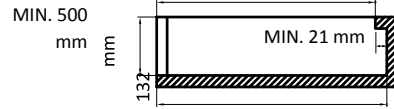

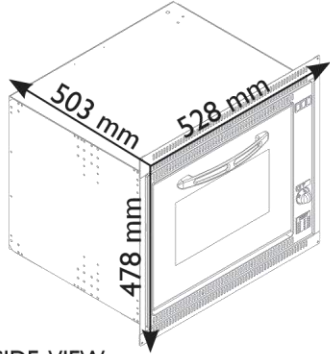

FRONT VIEW

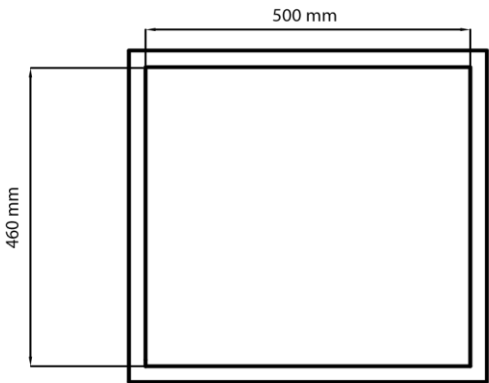

SIDE VIEW

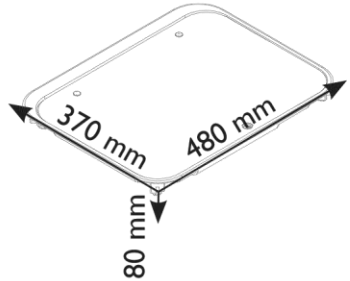
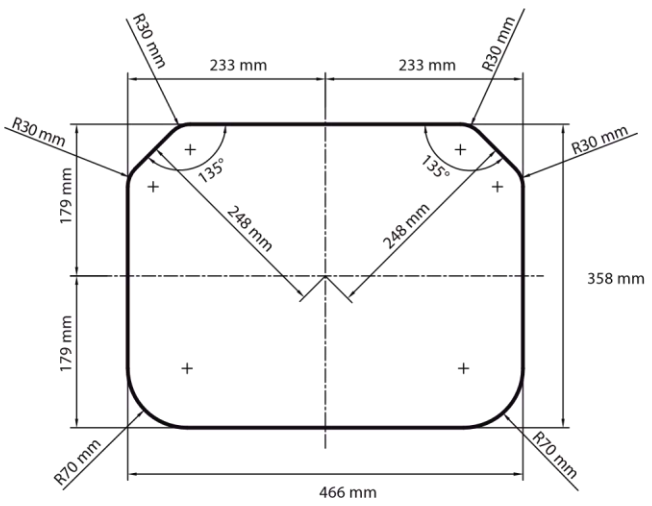
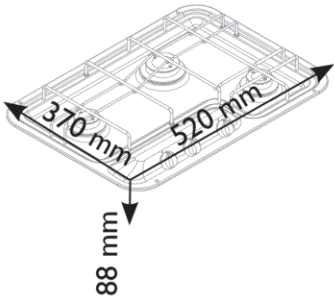
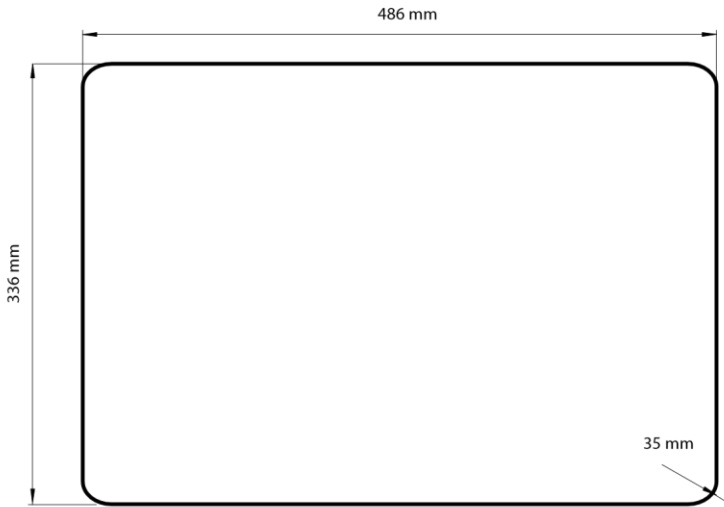
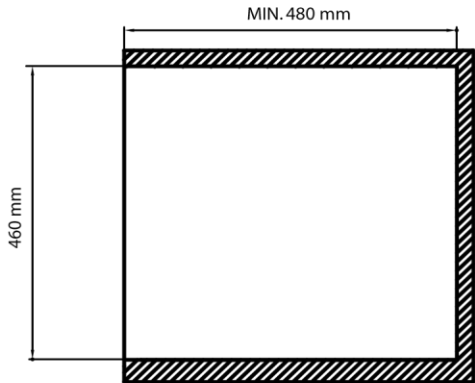

TECHNICAL DRAWINGS

PI0913

PI0913A

PI8002

PI8022

PI8003
PI8023

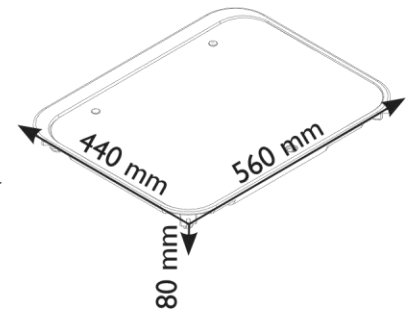
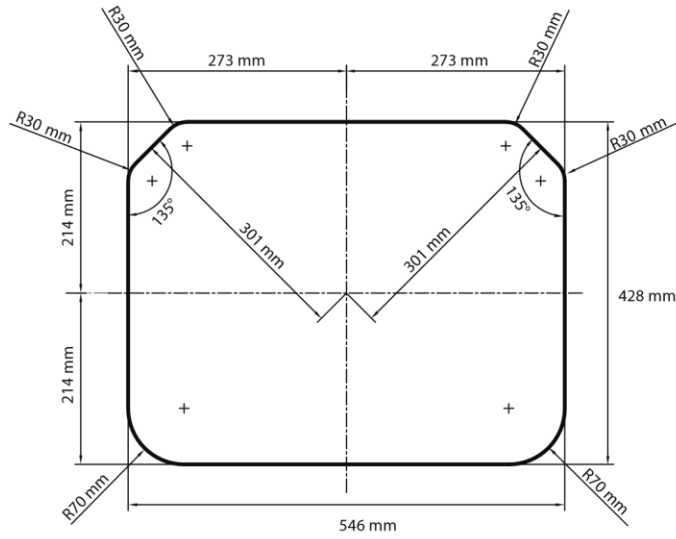

PI8403 - PI8403GL
PI8423 - PI8423GL
PI8443 - PI8463

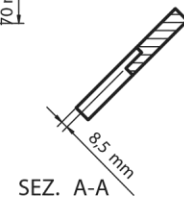
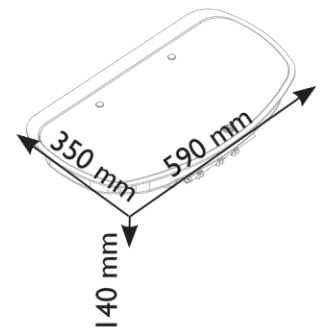
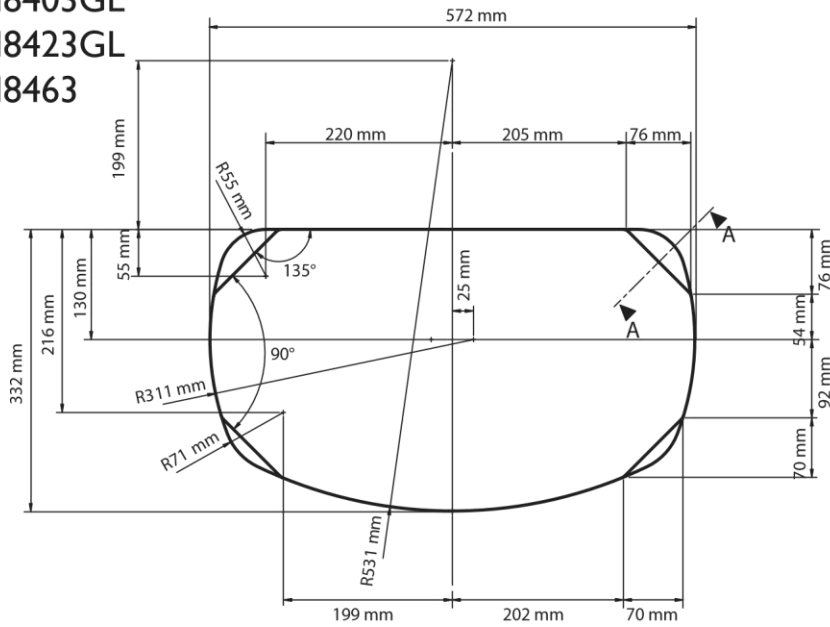

TECHNICAL DRAWINGS

PI8621A PI8621R

PI8621S

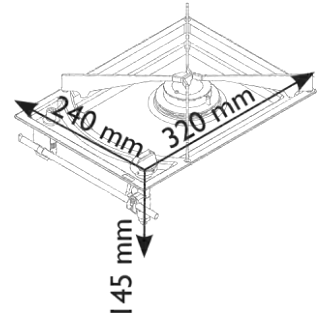
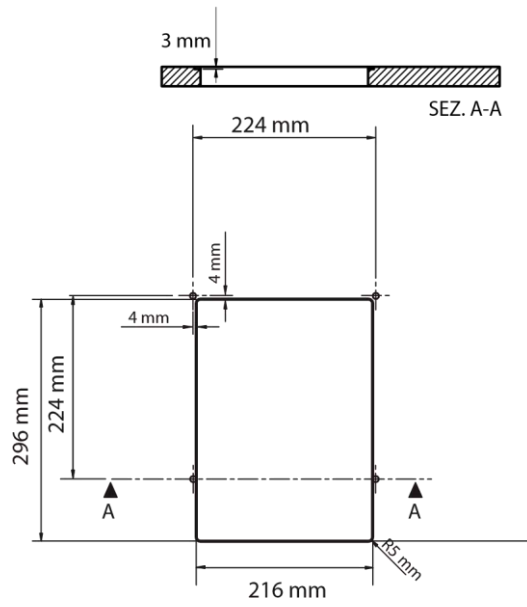

MO8103

MO8123

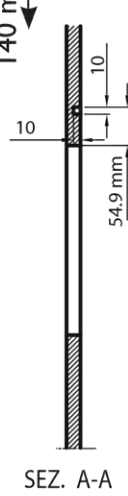
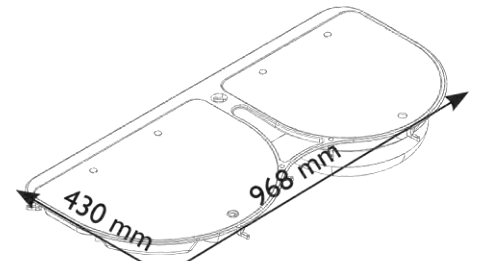
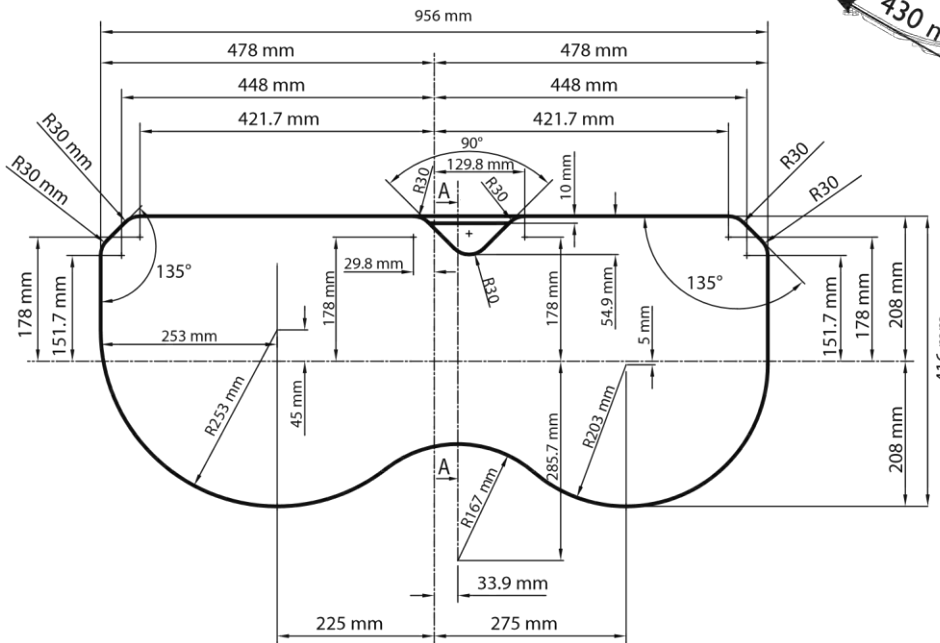

VN555

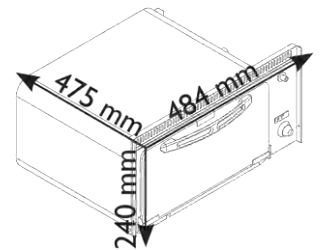



TECHNICAL DRAWINGS
SIDE VIEW

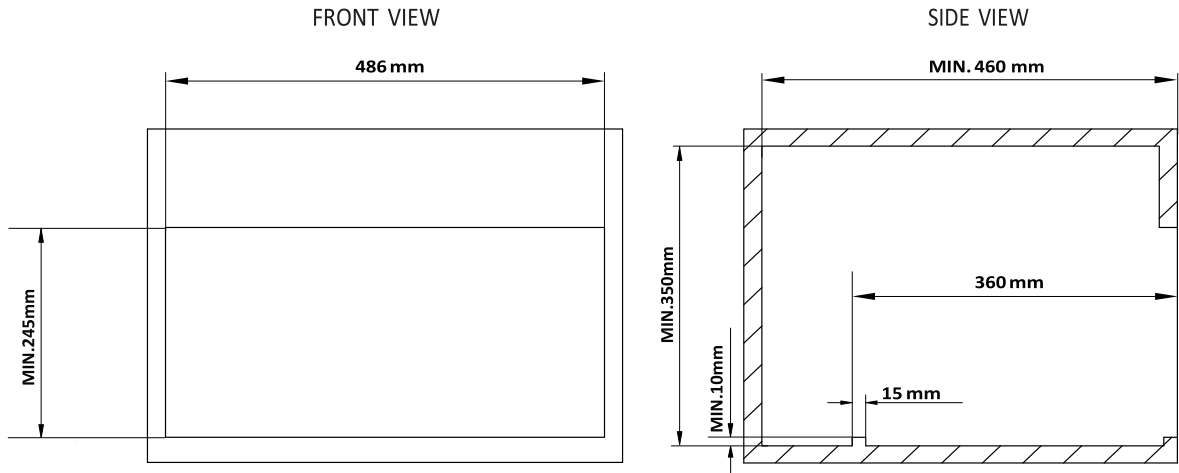
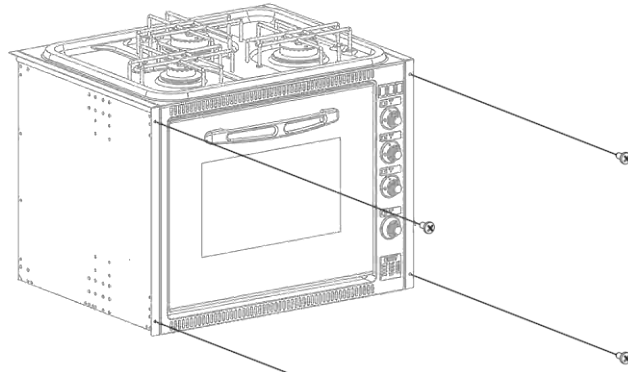

Figure 6

TECHNICAL DRAWINGS

CU311
CU333
CU335



CU311M
CU335M

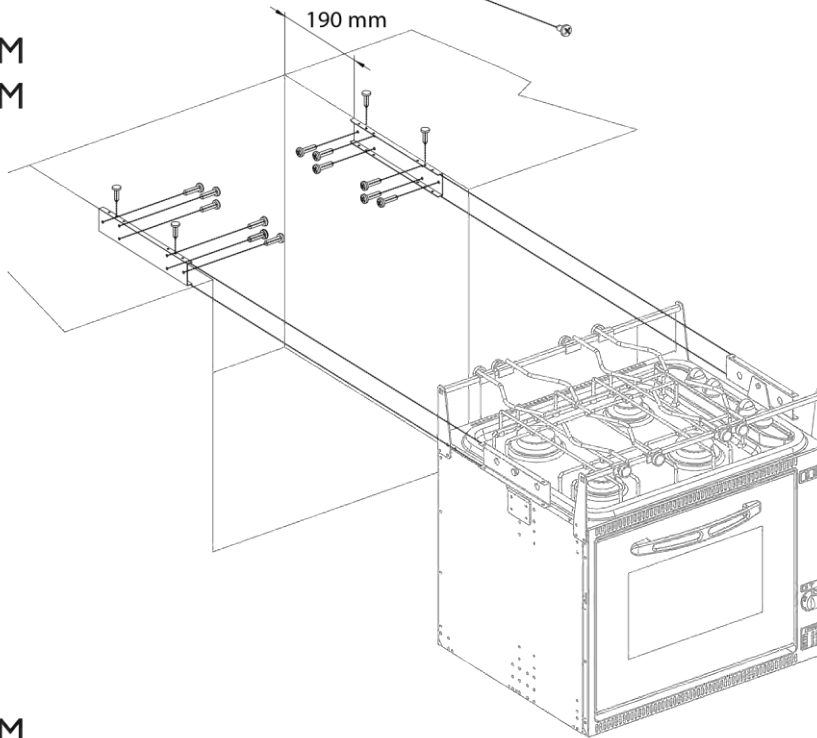

CU333M

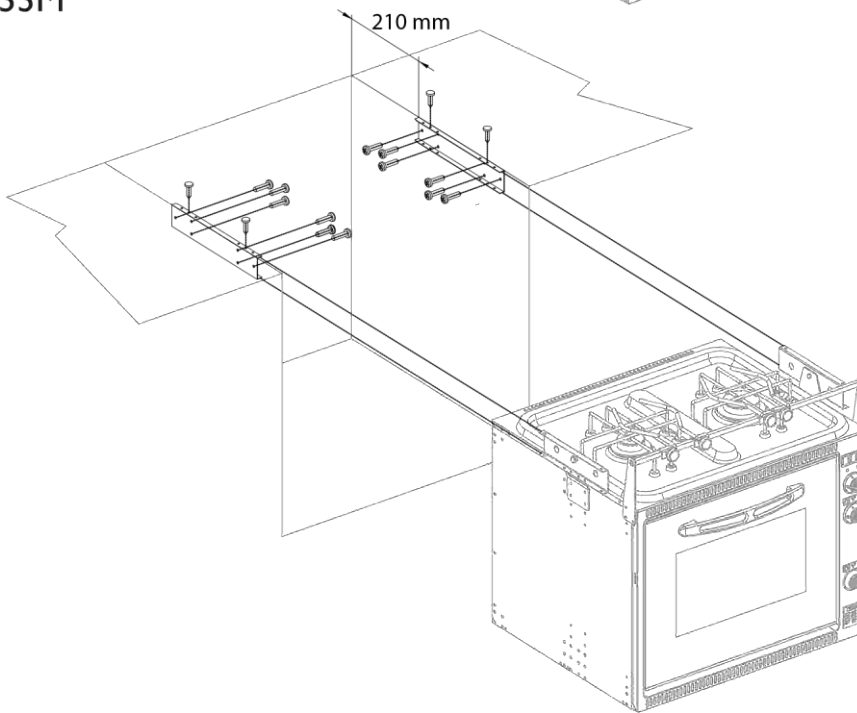

CU401
CU401PE

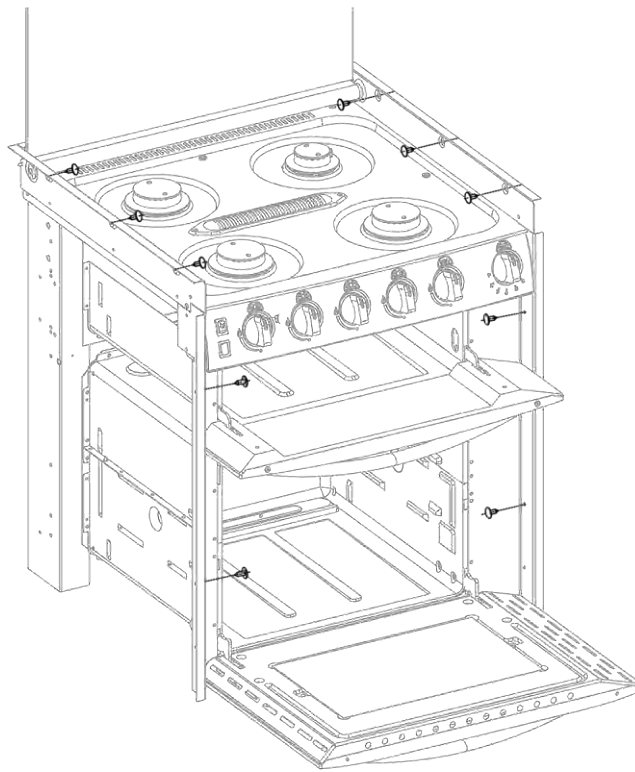

CU402 CU402PE

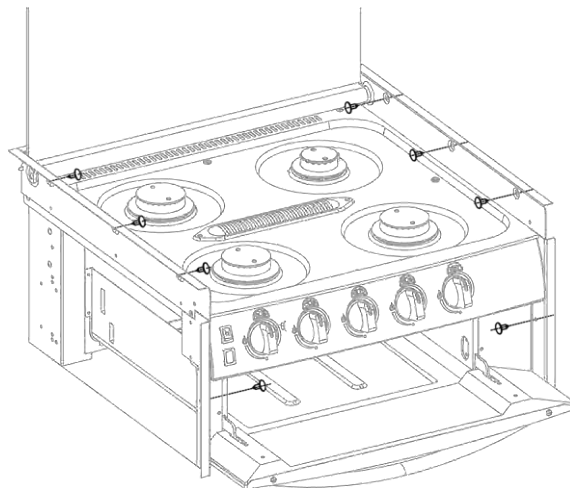

CU403
CU403PE

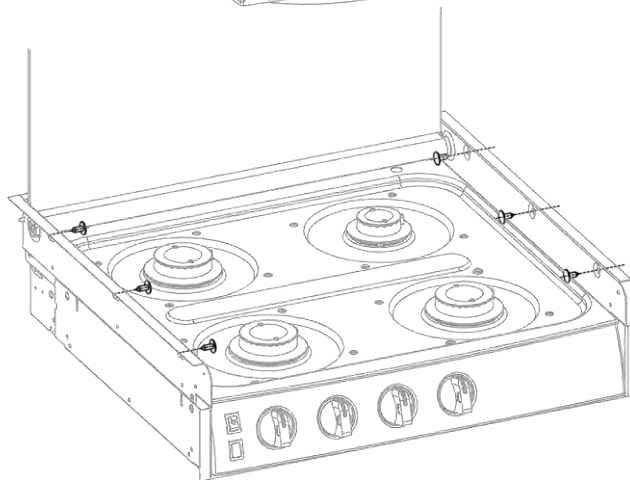

FO311

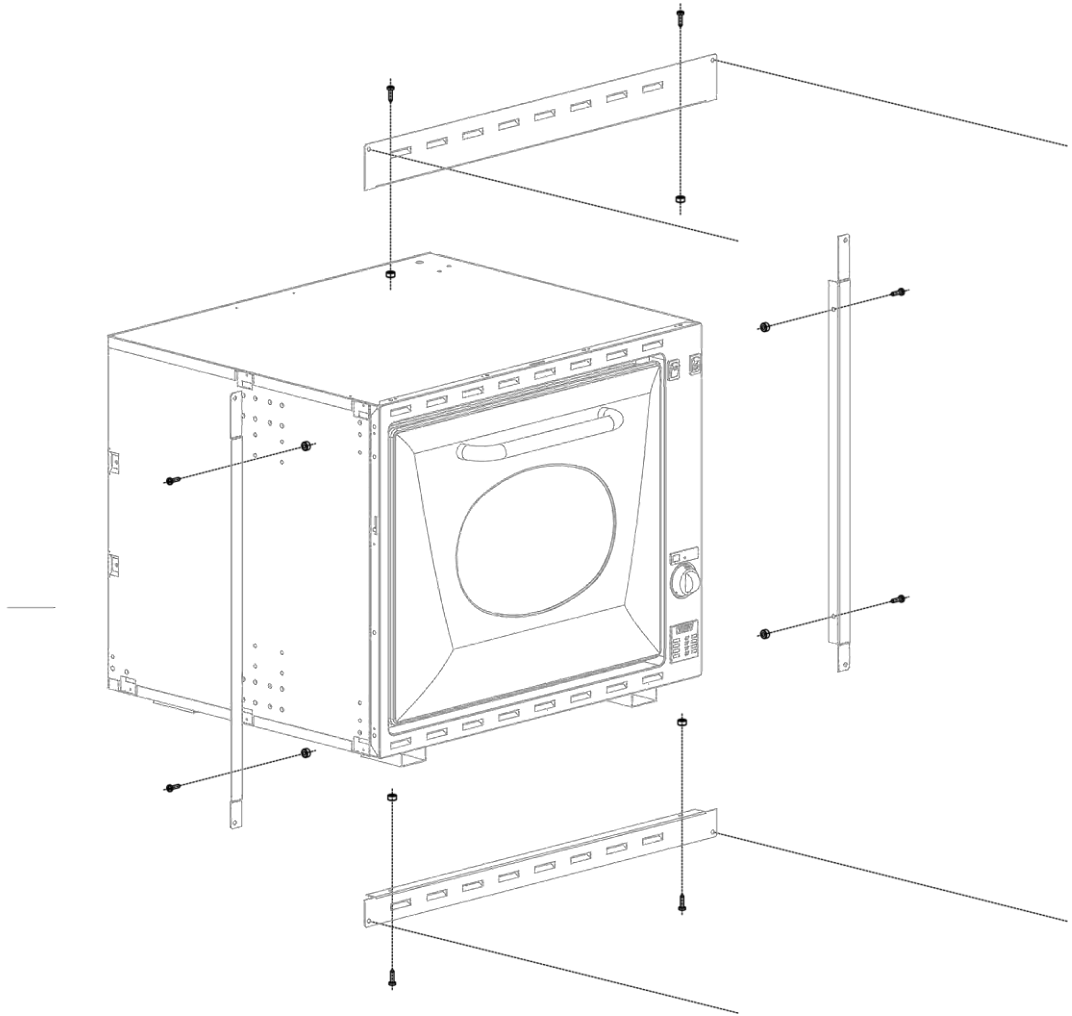

PI0913

PI0913A

PI8621A PI8621R

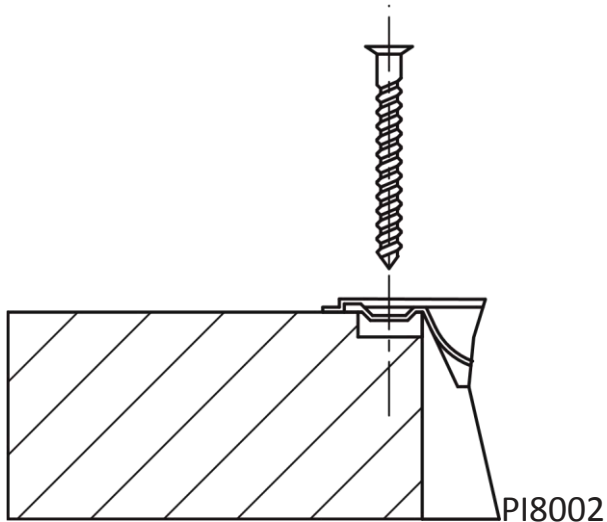

PI8621S

PI8002

PI8022

PI8003

PI8023

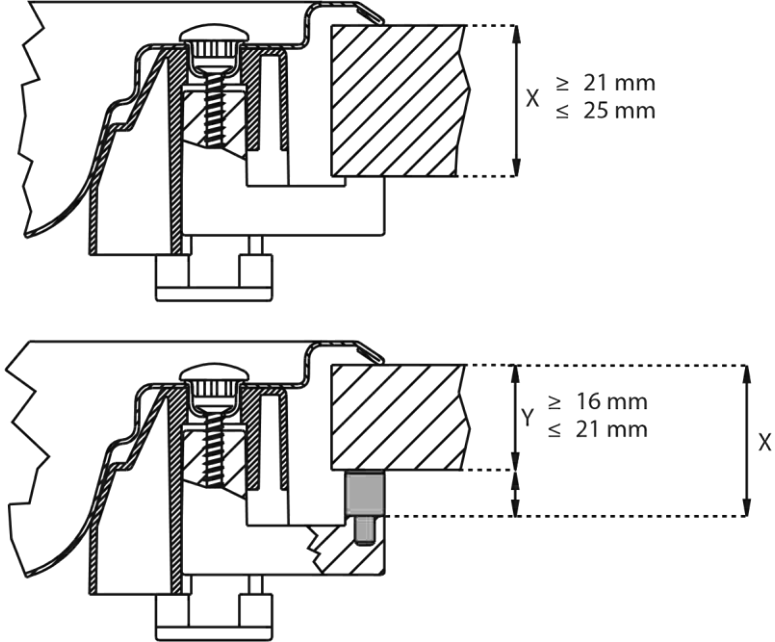

PI8403 - PI8403GL
PI8423 - PI8423GL
PI8443 - PI8463

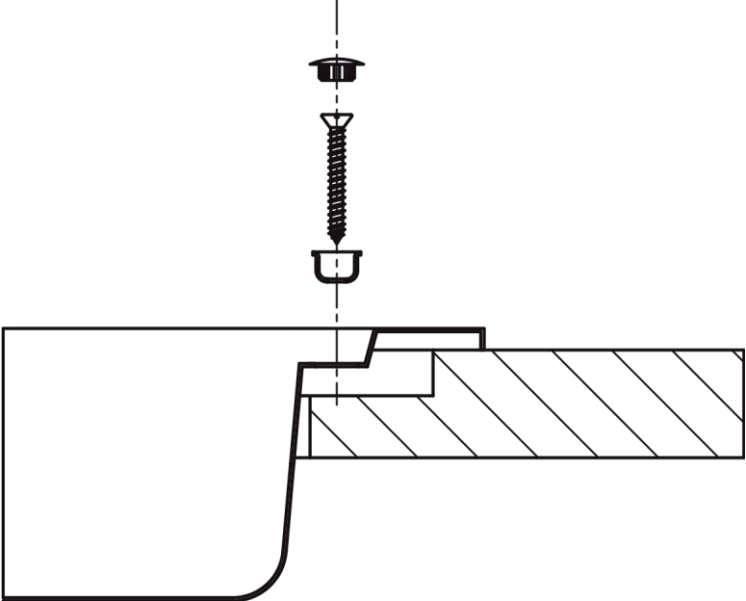

MO8103
MO8123

TECHNICAL DRAWINGS

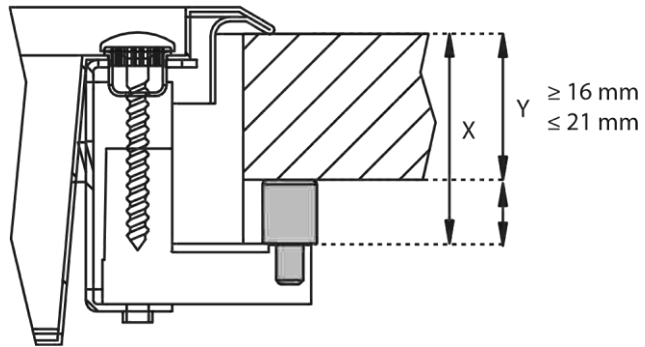
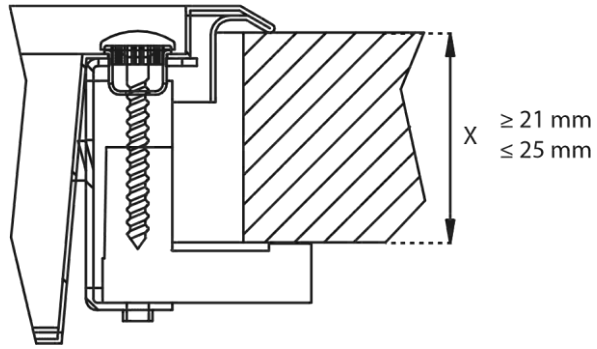

VN555

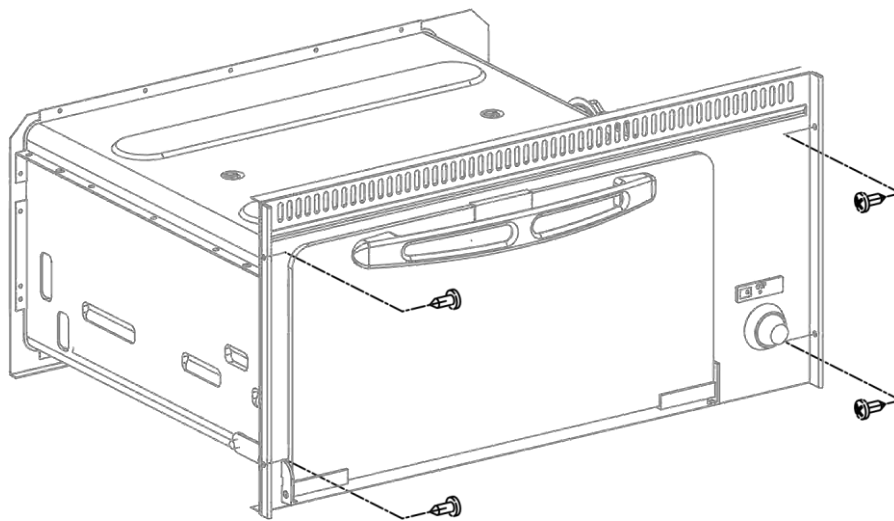

Figure 7



Figure 8

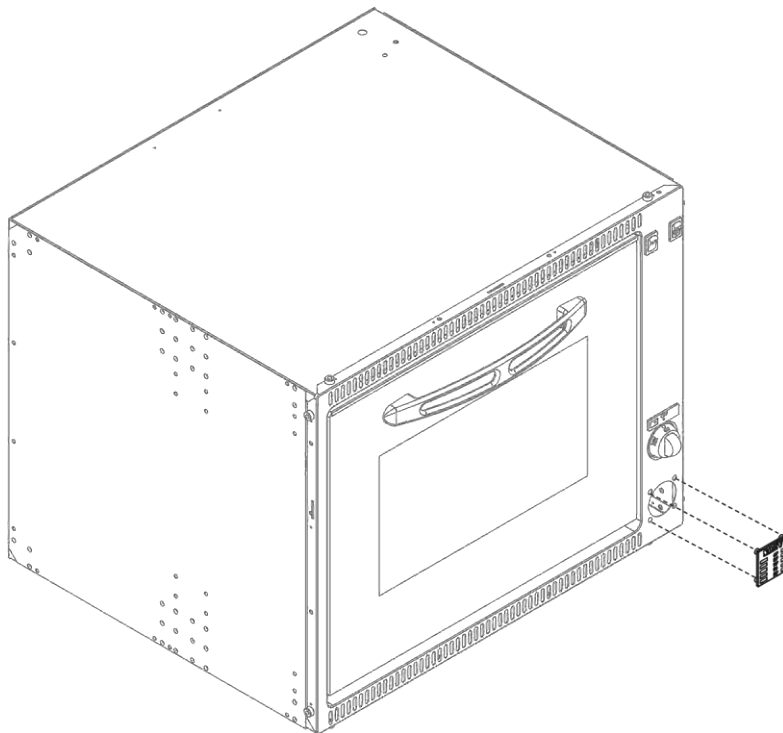
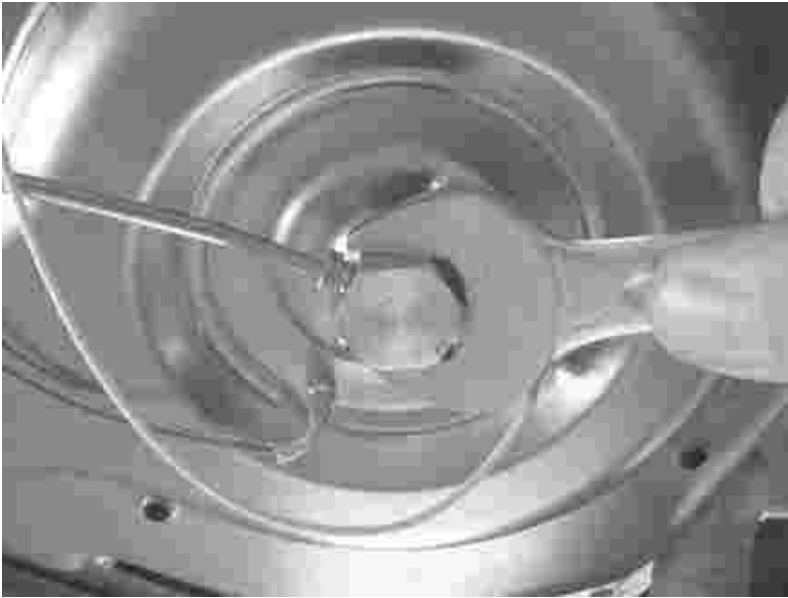

Figure 9

TECHNICAL DRAWINGS



Notes

.....
.....

.....
.....

.....
.....

.....
.....

.....
.....

.....
.....

.....
.....

.....
.....

.....
.....

.....
.....

.....
.....

.....
.....

.....
.....

.....
.....

.....
.....

.....
.....

WHO TO CONTACT

For service of your appliance, firstly contact your selling agent.

Australia

Dometic Australia, Queensland 1

1 John Duncan Court Varsity Lakes QLD
4227 phone: +61 (0)7 5507 6000 fax:
+61 (0)7 5507 6001 e-mail:
sales@dometic-waeco.com.au web:
www.dometic-waeco.com.au

Dometic Australia, Queensland 2

2/129 South Pine Road Brendale QLD
4500 phone: +61 (0)7 3205 7599 fax:
+61 (0)7 3881 1405 e-mail:
sales@dometic-waeco.com.au web:
www.dometic-waeco.com.au

Dometic Australia, Victoria

New Zealand

Dometic New Zealand Limited, Auckland

Unit 15, 180 Montgomerie Road
Airport Oaks, Auckland 1701
phone: +64 (0)9 256 0018 fax:
+64 (0)9 256 0017 e-mail:
sales2@dometic.co.nz web:
www.dometic.co.nz

Bldg 3B, Clayton Business Park 1508
Centre Rd, Clayton VIC 3168 phone:
+61 (0)3 9239 1000 fax: +61
(0)3 9239 1099 e-mail:
sales@dometic-waeco.com.au web:
www.dometic-waeco.com.au

Dometic Australia, Western Australia

12 Prosperity Ave, Wangara WA 6065
phone: +61 (0)8 9209 3033 fax: +61
(0)8 9209 3577 e-mail:
sales@dometic-waeco.com.au web:
www.dometic-waeco.com.au

Dometic New Zealand Limited, Wellington

26 Cashew Street Grenada North,
Wellington 6440 phone: +64 (0)4 232
3898 fax: +64 (0)4 232 3878 e-mail:
customerservices@dometic.co.nz web:
www.dometic.co.nz

