

Model:3J-EDS



Content

Use

Names of Main Parts-----	02
Functions & Parameters-----	03
Causions-----	04
Use of the EDS-----	05

Installation

Installation Spec-----	08
Packing List-----	10
EDS Installation-----	11
Trouble Shooting-----	14

Others

Warranty Articles-----	15
Warranty Card-----	16

○ We appreciate your fondness for our product! Please read through this manual before mounting, and keep it properly in case of re-using it someday.

Name of the Main Parts

Electric Door Step

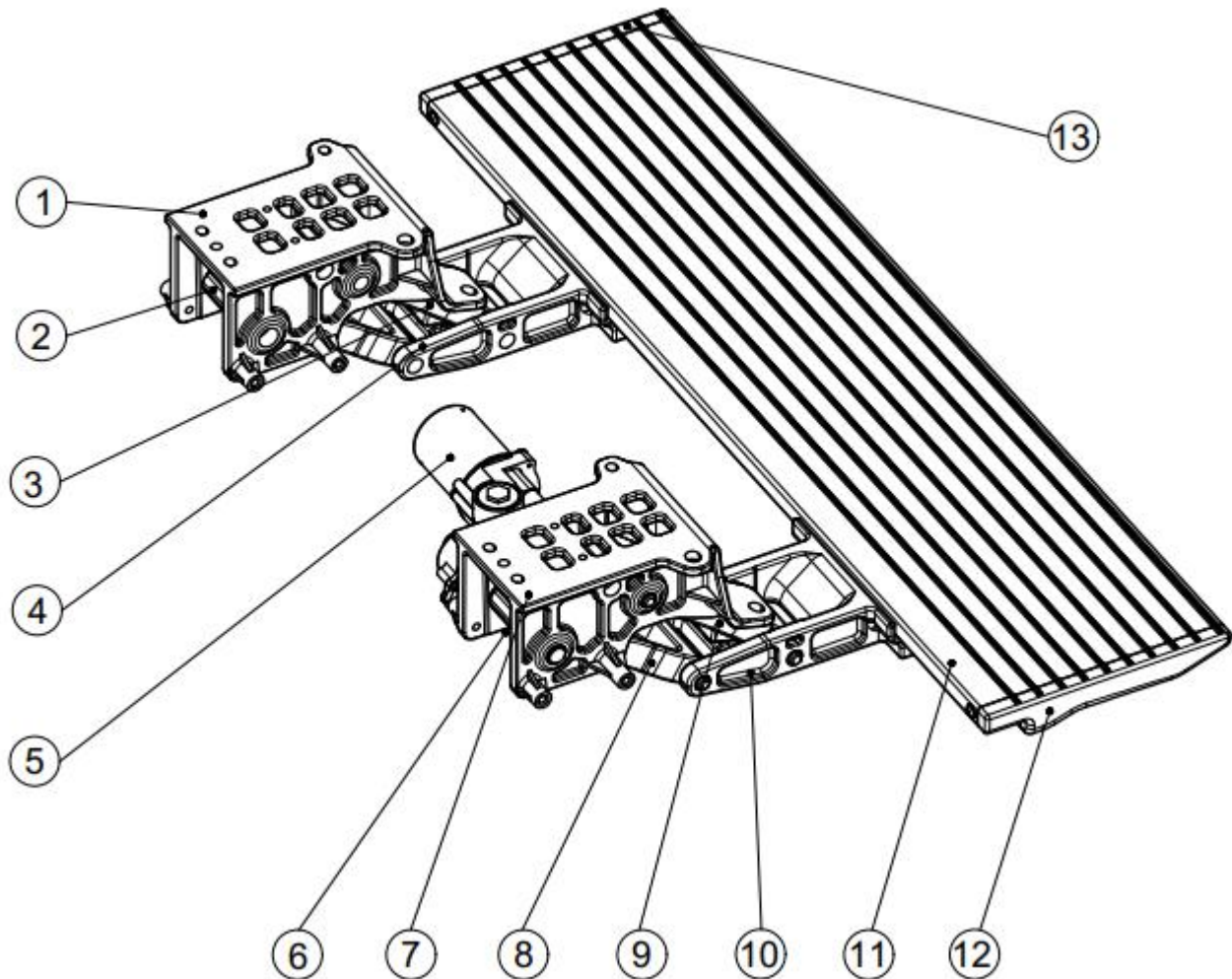

- | | | |
|-----------------------------|-----------------------------|-----------------------|
| ① Fixed Supports(Left) | ⑦ Fixed Supports(Right) | ⑬ Pedal End Cap(Left) |
| ② Main Drive Swing Arm B | ⑧ Main Drive Swing Arm A | |
| ③ Auxiliary Drive Swing Arm | ⑨ Auxiliary Drive Swing Arm | |
| ④ Pedal Supports(Left) | ⑩ Pedal Supports(Right) | |
| ⑤ Motor for EDS | ⑪ Pedal | |
| ⑥ Wedge Bolt | ⑫ Pedal End Cap(Right) | |

Functions & Parameters

Functions for Safety and Protecting	
Protection	The Door Step will be inextensible when the vehicle is linked to CAN/LIN signals and the driving speed is $\geq 8\text{km/h}$; the vehicle will be unable to be started under its own power when the EDS is extended;
Anti-Pinch	In the process of being turned on/off, the EDS will retract back to the off/on position if the resistance $\leq 100\text{N}$;
Voltage-Protection	When the input voltage of the EDS is $< 9\text{V}$ or $> 16\text{V}$, it will stop working, activating the voltage-protection in case of storage battery feeding and any damage to the EDS;
Central Locking Protection	High level signal(unlocked) of the Central Locking Protection is the default signal. If the Central Locking line touches with the earth line, the signal of central locking line will be turned into low level signal(locked), retracting the EDS and locking its use.





Property Parameters	
Pedal Spec	W*L=230mm*600mm(adjustable Length, 550mm~1100mm)
Motion Spell	2.0S for the EDS extension from beginning to the fullest extent and 2.0S for the EDS retraction from beginning to the fullest extent
Voltage	Normal Voltage: 12V; Work Voltage: 6-12V(EDS stops working if the voltage $< 9\text{V}$ or $> 16\text{V}$)
Electric Current	Non-load current of the motor: 2A; Max Instantaneous Current $\leq 7\text{A}$; Locked Rotor Current $\leq 30\text{A}$
Anti-Pinch Force	Protect users from being pinched as the EDS extends/retracts, with anti-pinch force $\leq 100\text{N}$
EDS Endurance	100,000 cycles of extension and retraction without anomaly.
Working Noise	Motor noise $\leq 50\text{dB}$, overall noise $\leq 60\text{dB}$
Working Temp	Working temp range for EDS: -40°C to 85°C
Static Bearing Capacity	Greater than 280Kg
Motor Protection Grade	Protection Grade: IP67
Vehicle Communication Interface	Communication Interface: CAN/LIN
Surface Spraying	Salt Spray Test for over 720h and no surface corrosion detected
H/L Temp Endurance	The machine could still perform the two states(extension/retraction) over 100 times respectively after being placed in an environment with a temp of -40°C for 40 hours, and then heated the environment to $(+23\pm 3)^{\circ}\text{C}$ and kept it there for 4 hours.
H/L Temp Shock	The machine managed to demonstrate a smooth cycle of extension and retraction, and qualified anti-pinch force and the noise level;

Cautions

Please read over this manual before mounting, and perform the mounting in strict accordance with the instructions. Keep the manual properly after reading.

Please obey the safety warnings and cautions in case of any injury or financial loss to the users or someone else.

○ Signs and corresponding Meanings

	Caution! It's possible to cause severe injury or damage.
	Caution! It's possible to cause damage if the instructions are not followed in the operation process.
	This sign means such an operation is banned.
	This sign means a remark on related information.

Warning!

1. The installation of this product should be handled by professionals as far as possible;
2. The manufacturer will not take on any responsibility if the product, damaged by external forces, is refitted without express permission of the manufacturer;
3. Please retract the EDS before driving the vehicle,. Otherwise, it will be potentially hazardous to drive;
4. The distance of the EDS pedal and the bottom of the vehicle shell shall be $\geq 50\text{mm}$ in case the EDS pedal interferes with the vehicle shell when extending;
5. The distance of the bottom position of the moving EDS pedal and the floor shall be $\geq 50\text{mm}$ in case the pedal touches the floor when extending or retracting;
6. The EDS installation side on the chassis shall be guaranteed to be on the same horizontal level with the chassis, and the height error of both end of the installation side shall be $\leq 5\text{mm}$;
7. The power supply system of the vehicle shall be capable of supporting 30A current, the extension and retracting of the EDS generates Instantaneous Current of $\leq 7\text{A}$; Locked rotor current of the EDS is $< 30\text{A}$.

Attention!

1. Please consult the dealer with any solution if any malfunction occurs.
2. Please check whether the EDS has been properly retracted before driving and the commencement of your journey.
3. Please check the surrounding conditions as far as possible before using the EDS and guarantee a proper use of it.

Use of the EDS

Door Signal Switch and Control

Door Linked Switch	Door signal with black wires- red wires touching	Door signal with black wires- red wires detecting	Central Locking Signal wires connecting the earth wire
Corresponding Function	EDS extension	EDS retraction	EDS retraction and lock

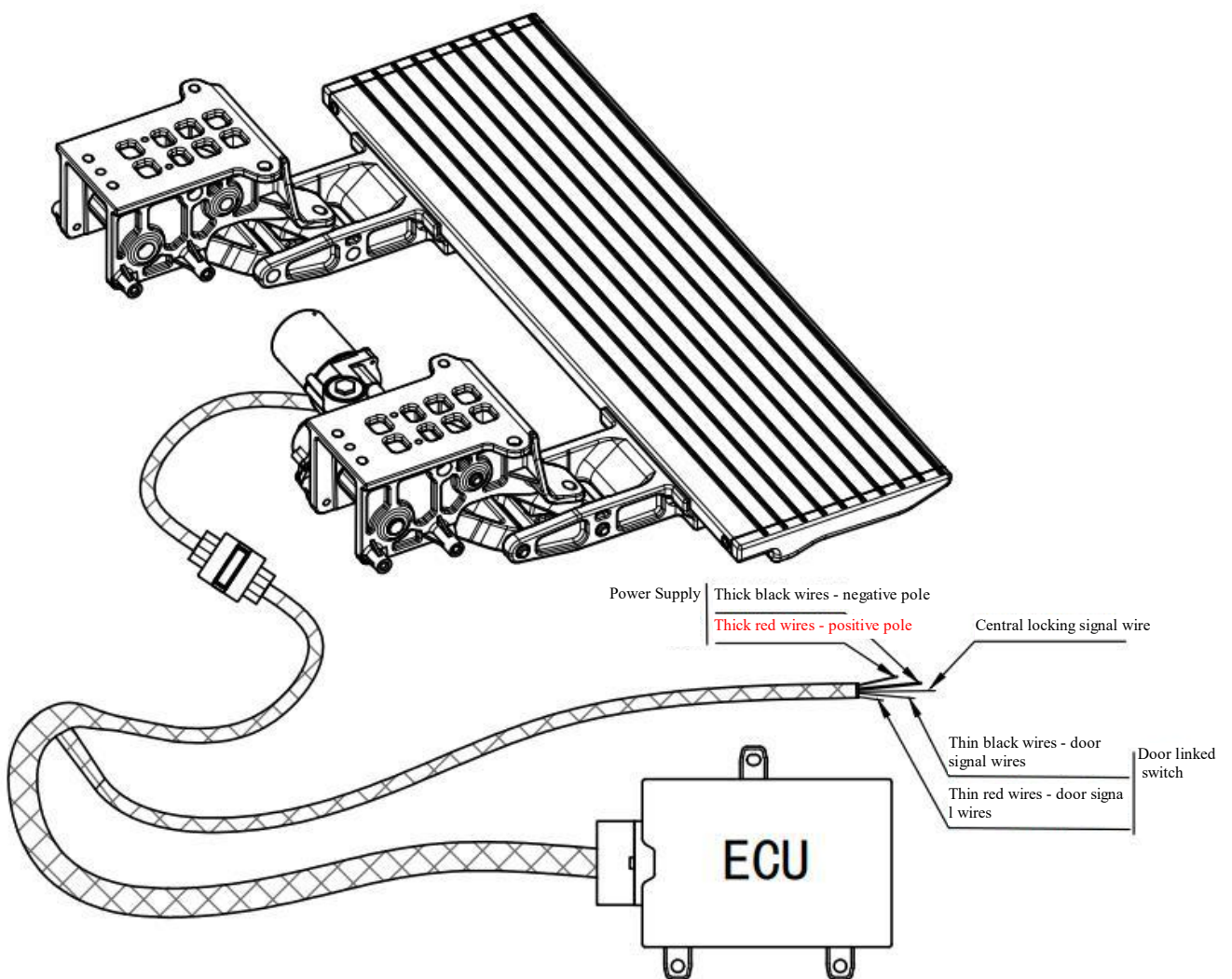

Please retract the EDS if you are to leave the vehicle for a long time!

Use of the EDS

EDS Extension

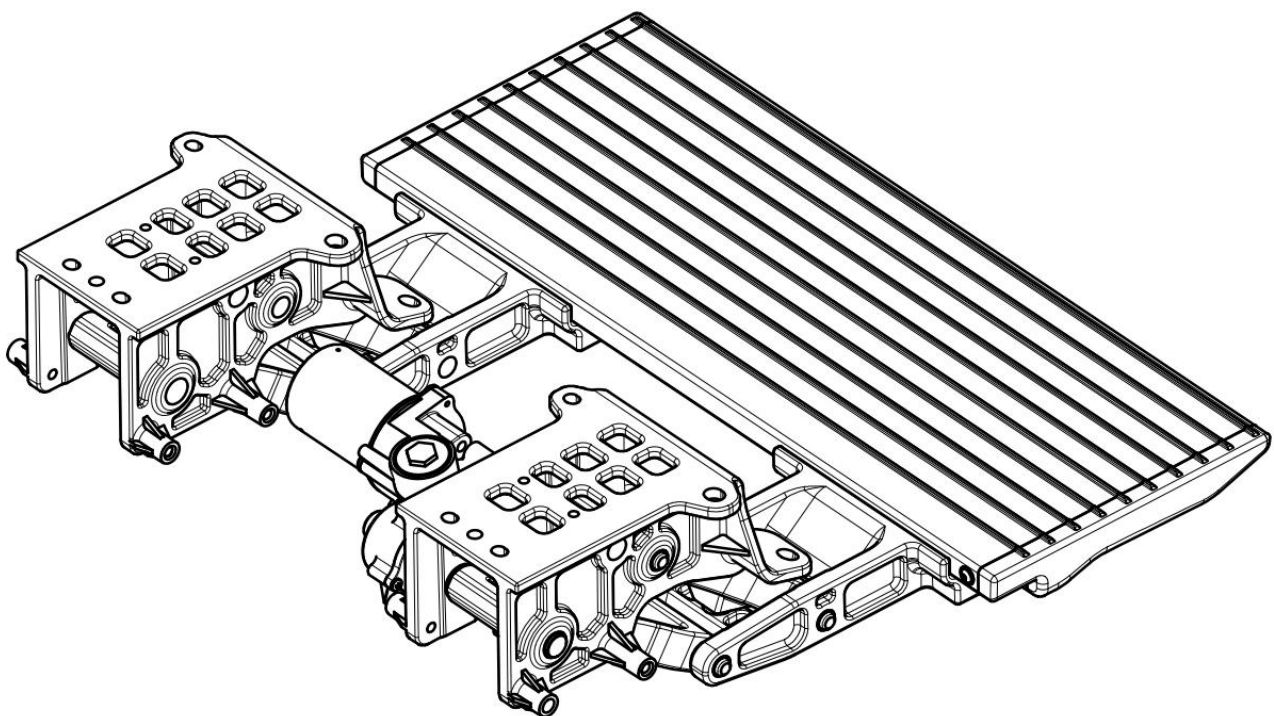
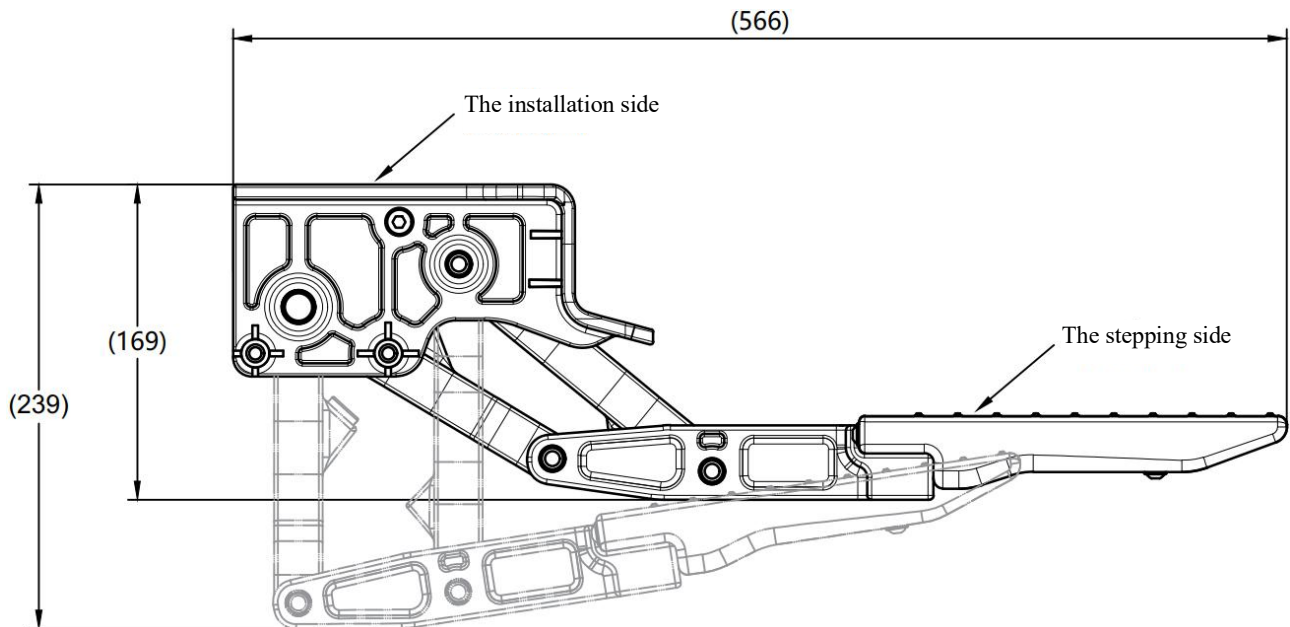

It's suggested to the users not to step onto the electric pedal until it's fully extended.

Use of the EDS

EDS Retraction

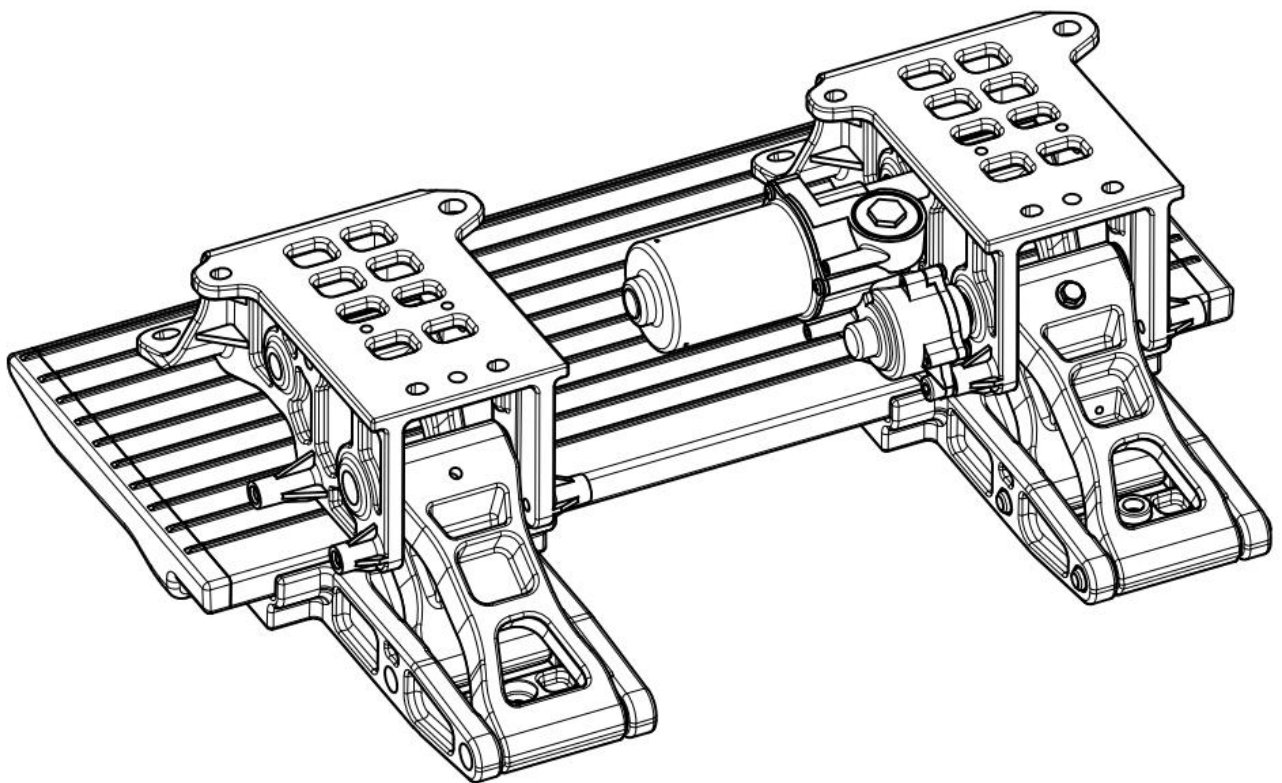
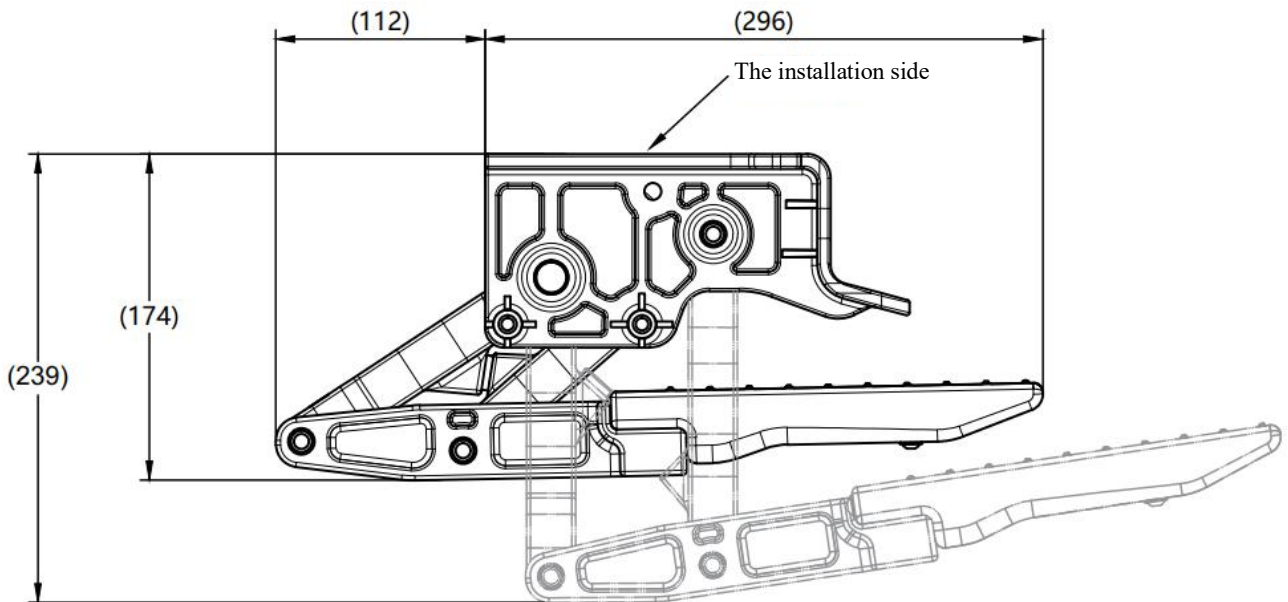

 Please make sure the EDS is retracted before driving!

Installation Spec

EDS

Unit:mm

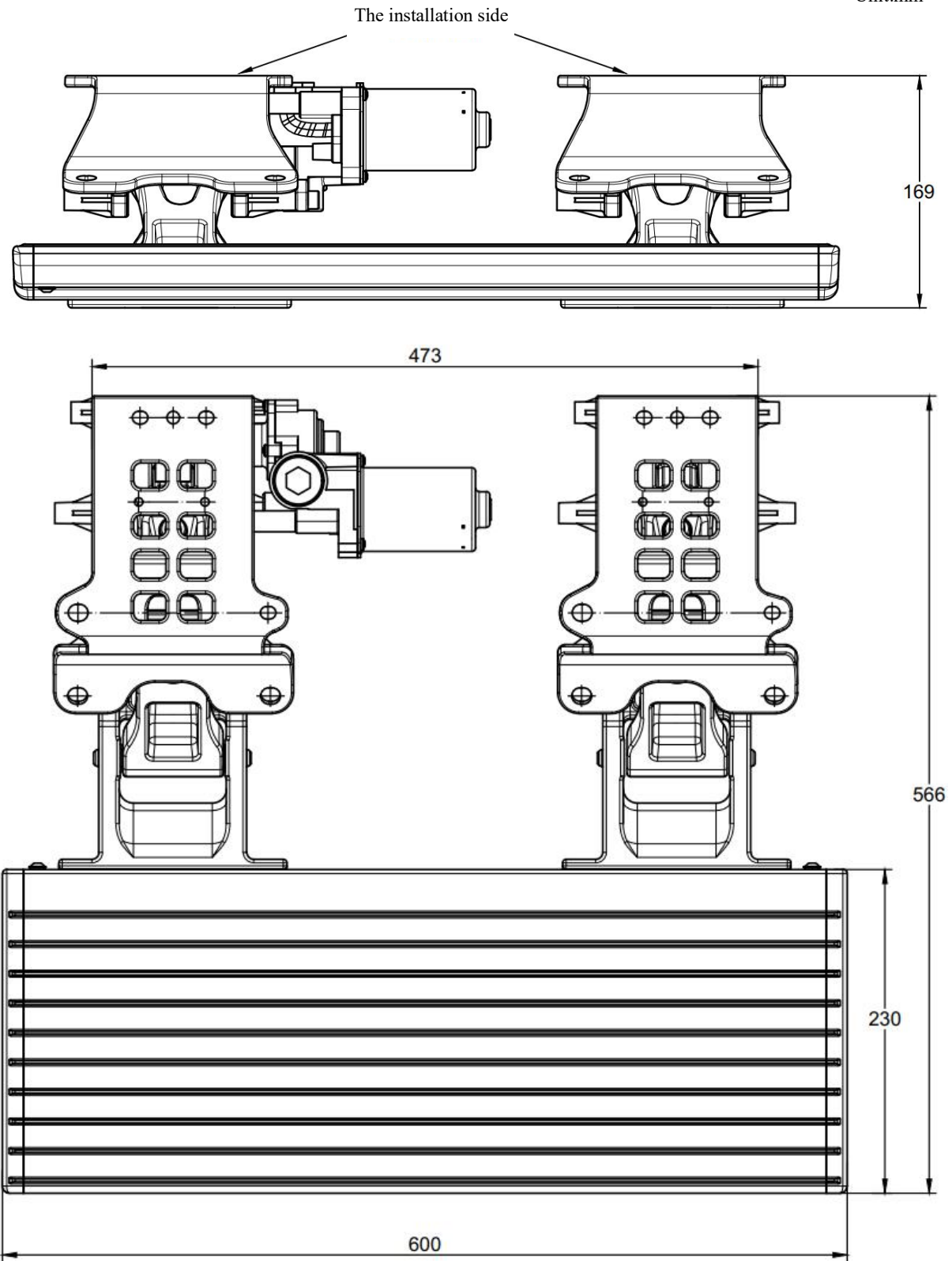

Installation Spec

ECU

Unit:mm

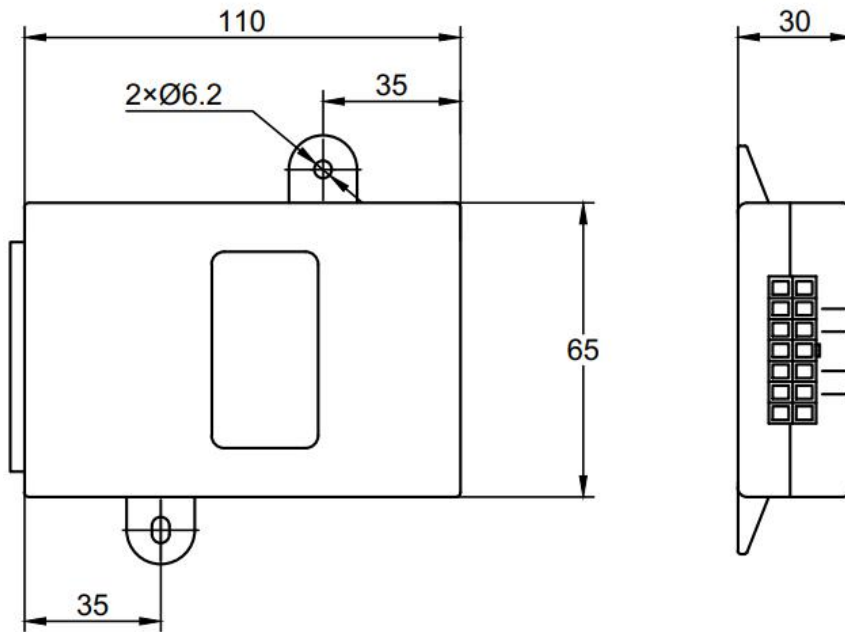

Wiring Harness

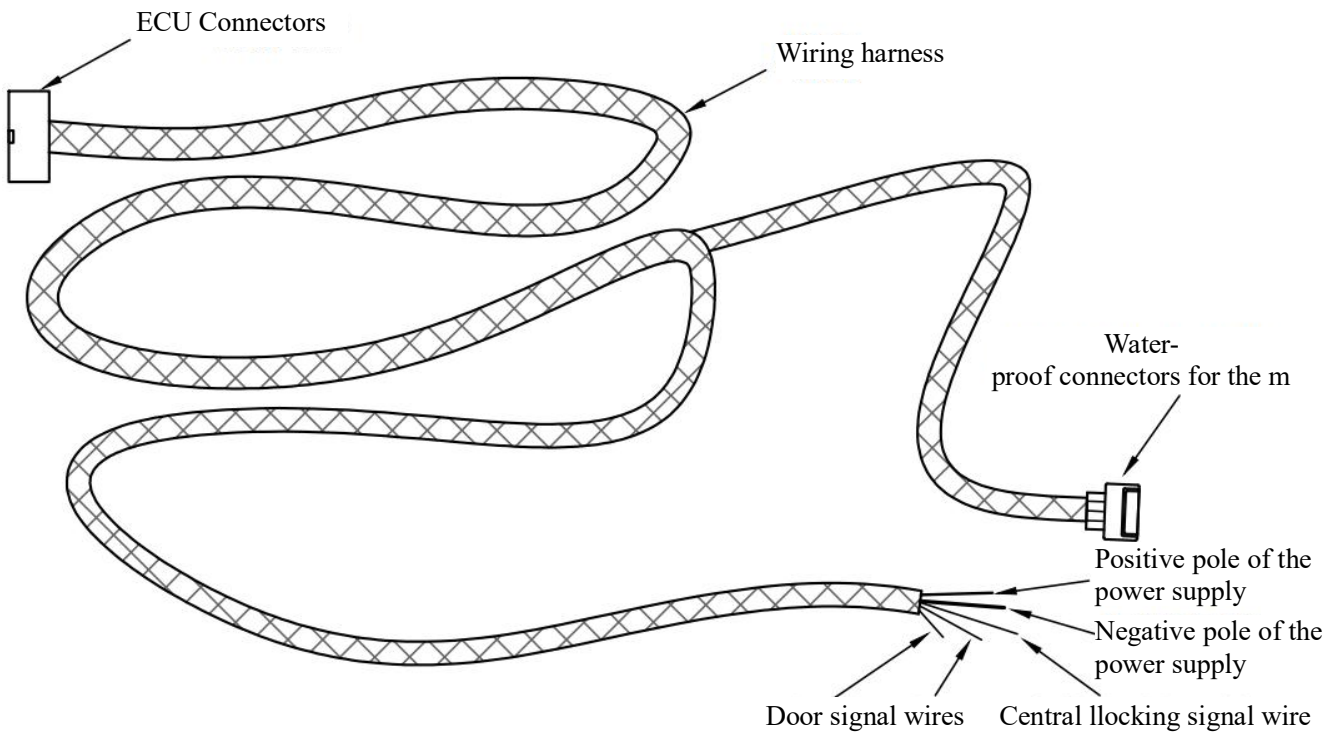

Packing List

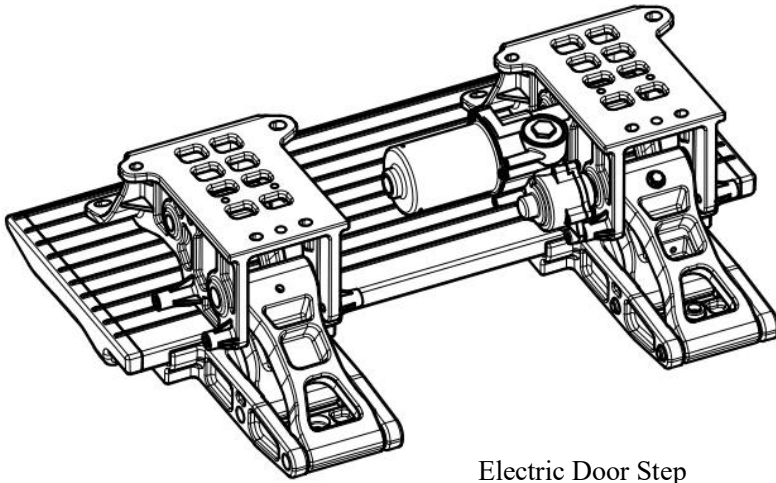

Electric Door Step

1

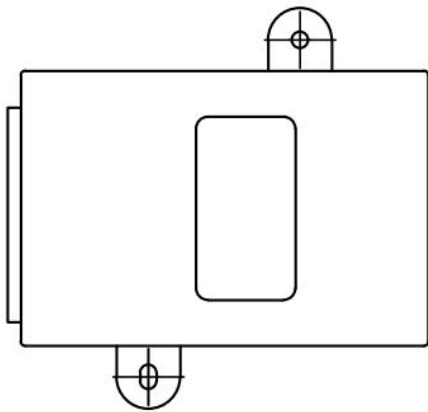

ECU

1

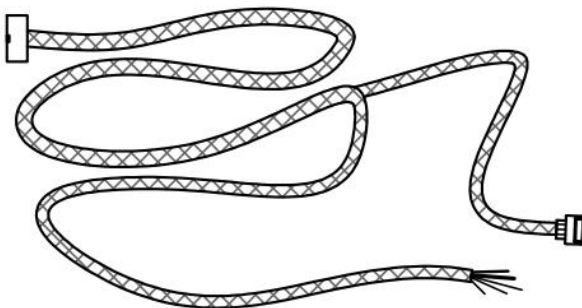

Wiring Harness

1

EDS Installation

1. The installation position is right beneath the RV's door(as shown of the image below), and is at the central position of the door's opening.

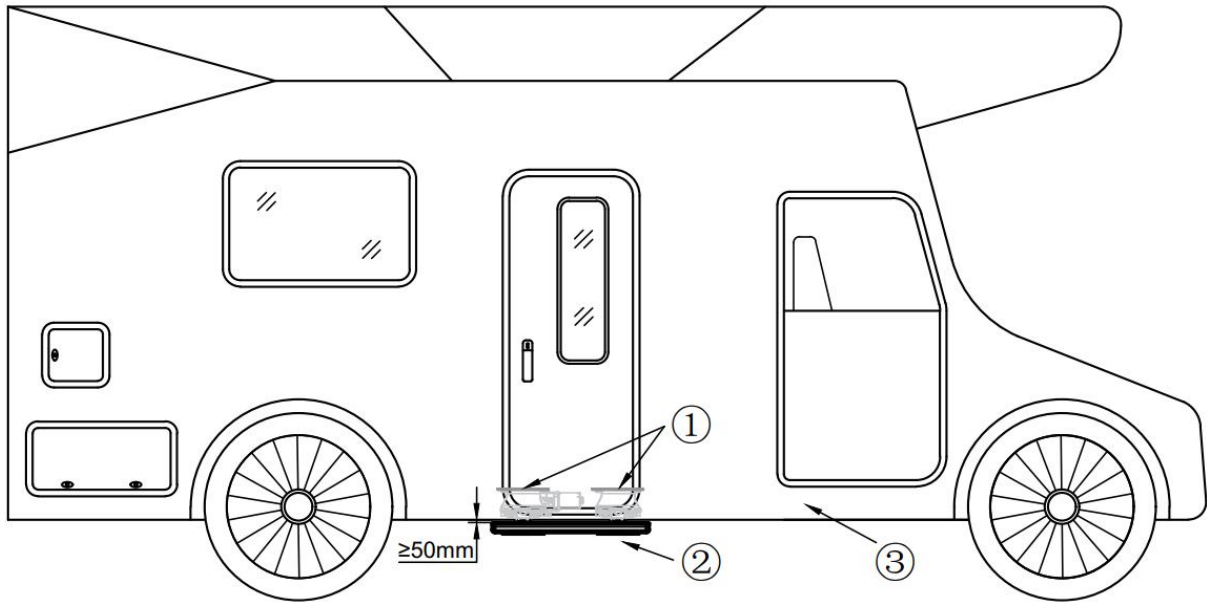

2. Diagrammatic Drawing of EDS Mounting Board(It's suggested to install the EDS Mounting Boards as a integrated whole so as to guarantee that the EDS installation sides are all on a same horizontal level, reducing EDS errors caused by installation)

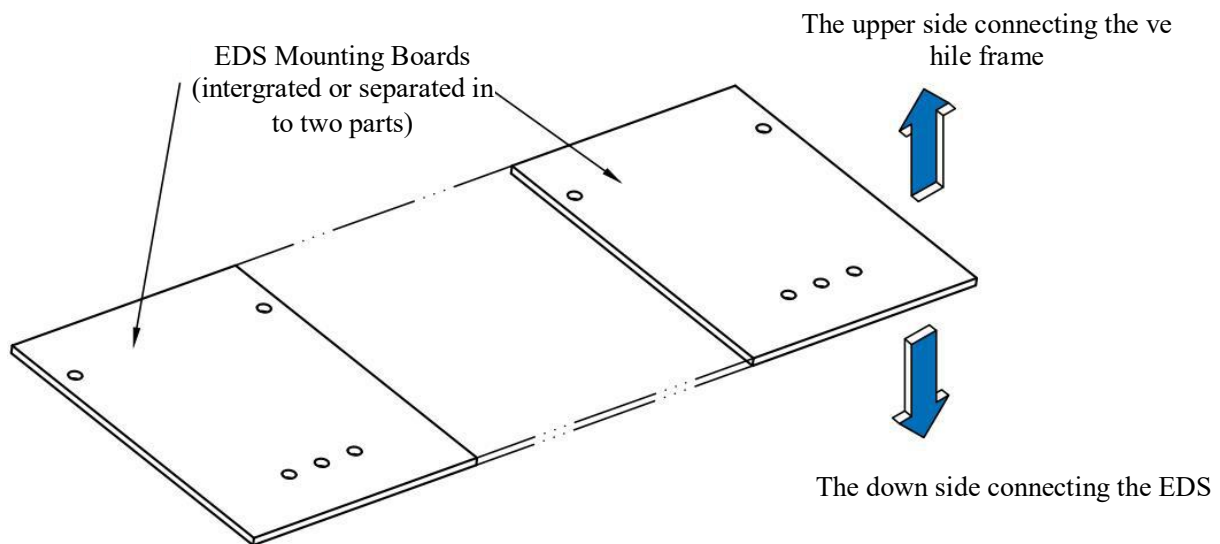

! Attention! The distance of the pedal and the bottom of the vehicle shell shall be $\geq 50\text{mm}$ in case of any interference in the EDS extension against the vehicle shell!

i The EDS should be kept align with the center of the door's opening and the pedal should be kept horizontal;

EDS Installation

3. Line the EDS mounting holes up with the corresponding holes of the installation boards, and use M8×25 hexagon socket bolts(10 PCS) to fix the EDS on the installation boards

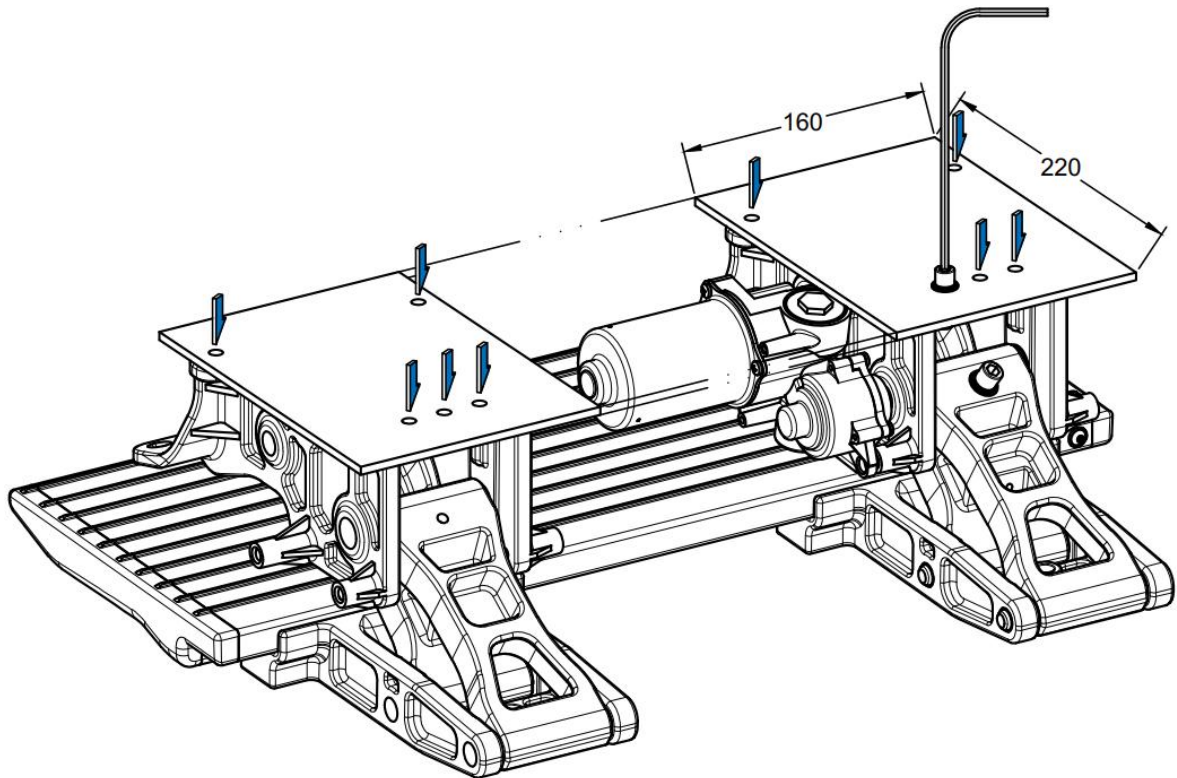

Materials & Tools for the Mounting

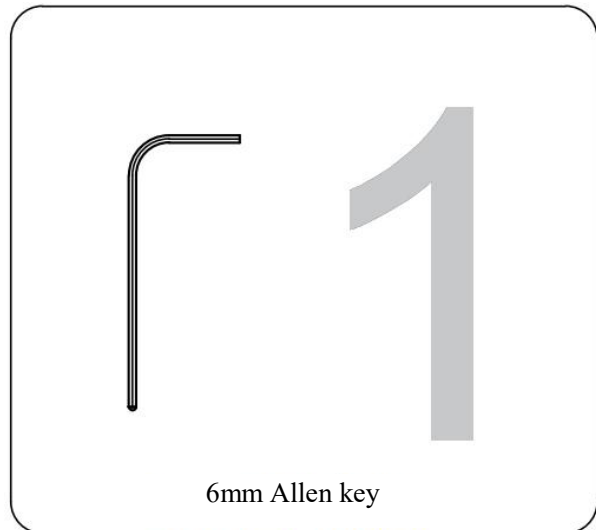
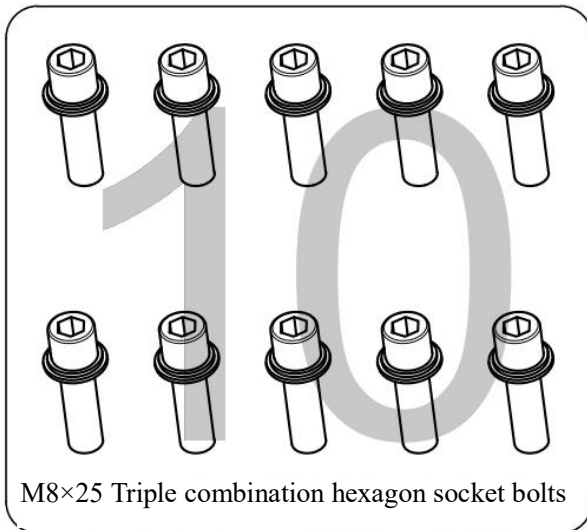

The EDS Installation Boards should be fixed at the bottom of the vehicle shell to guarantee them on the same level in case of warping after the installation.



The ECU must be kept inside the car with a dry environment in case of malfunction caused by damp.

EDS Installation

4. Connect the Door Linked Switch after installing the EDS properly, and start the EDS testing & commissioning

①	Power on the EDS, and wait for the completion of auto-learning	Initial Power-on and the CL Signal gets disconnected; Open the door, waiting for the EDS to extend to the fullest extent automatically; close the door, waiting for the EDS to retract to the fullest extent automatically; Completing the above steps represents the completion of auto-learning; No anti-pinch function in the process of auto-learning.
②	Open & Close the door 3-5 times to check if there's any anomaly in the extension and retraction of the EDS;	Check if there's any anomaly in the linkage between the door opening and closing signals and the EDS;
③	Step it several times after the EDS fully extended to check if any anomaly in the installation exists	Check whether the installation is completed and if there's any looseness;
④	Use a hard object to block the extension in the middle when extending the EDS to check the anti-pinch for extension	Anti-pinch force test: the EDS will automatically retract when it gets blocked to protect the users;
⑤	Use a hard object to block the retraction in the middle when retracting the EDS to check the anti-pinch for retraction	Anti-pinch force test: the EDS will extend and retract again automatically when it gets blocked, and extend and retract again(if get blocked again), and the buzzer will be buzzing in the whole process, so as to protect the users;
⑥	In-off Central Locking Signal Test	Connect the CL signal to the earth wire, and retract the EDS, and the using function will be locked; Disconnect the CL signal to the earth wire, and the using function will be unlocked;

Trouble Shooting

Trouble Shooting	
EDS fails to move	Check whether the power voltage of the whole vehicle is lower than 9V or more than 16V or not;
	Check whether the Water-proof connector for the motor is loose or damaged;
	Check whether the ECU box is exposed or damped;
EDS Anomaly	Check whether the EDS is on the same level, and whether the whole mechanism is affected;
	Anti-pinch gets triggered by mistake. Check each rotating parts of the mechanism to see whether there's a hard object jammed in;
	Please clean the sand, mud, grass and other foreign matters on the EDS, and apply lubricating oil on the links after cleaning;
The EDS can not extend or retract to the preset position	Check the rotating parts of the mechanism to see whether there's a hard object jammed in;
	Please power off and re-start the EDS, and it will adjust itself to the initial position;

Warranty Article

1. The warranty period for the whole machine lasts for one year.
2. Please contact the manufacturer or the dealer for repair if any defect is discovered during the warranty period.
3. Paid repair and lifetime service will be offered during the warranty period if:
 - 1) The user cannot provide this Warranty Card and valid purchase evidence;
 - 2) The invoice is altered;
 - 3) The malfunction or damage is caused by accidents or improper usage;
 - 4) The malfunction or damage is caused by self-repair without the company's permission;
 - 5) The damage is caused by the usage of power supply or voltage beyond designation;
 - 6) It is a product beyond the valid period of "Three Guarantees" that remains in service after repair;
4. No other explicit or implicit guarantees(including implicit guarantees on marketability, and the reasonableness and fitness of some specific application) is made except the above-mentioned ones. The company holds no responsibility for any special, occasional or indirect damage, be it matters in regard to the contract, civil negligence or others.
5. The valid period of "Three Guarantees" starts from the date of issuance of the invoice, excluding the time of repair and wait-to-repair. Repair service, changing and refunding will be offered to the customer during the valid period of "three Guarantees" by providing the invoice and the "Three Guarantees" receipt.
6. Refunding, changing and repair will be offered to the customer as options within 7 days of the purchase if any malfunction happens.
7. Changing and repair will be offered to the customer as options within 15 days of the purchase if any malfunction happens.

Contact of Customer Service:

Warranty Card

Product Name: _____

Product Model: _____

Manufacturing No.: _____

Date of Production: _____

Customer Name: _____ Contact: _____

Customer Address: _____

Warranty Inclusion: _____

Customer Service: _____

Customer Signature: _____ Satisfied Unsatisfied

Warranty Inclusion: _____

Customer Service: _____

Customer Signature: _____ Satisfied Unsatisfied

Warranty Inclusion: _____

Customer Service: _____

Customer Signature: _____ Satisfied Unsatisfied
