



FLUSH MOUNT GAS BURNER COOKTOP

SPHERE 2 BURNER COOKTOP

Model: (GR-587)
Product Code: 700-05560

SPHERE 3 BURNER COOKTOP

Model: (GR-888)
Product Code: 700-005562

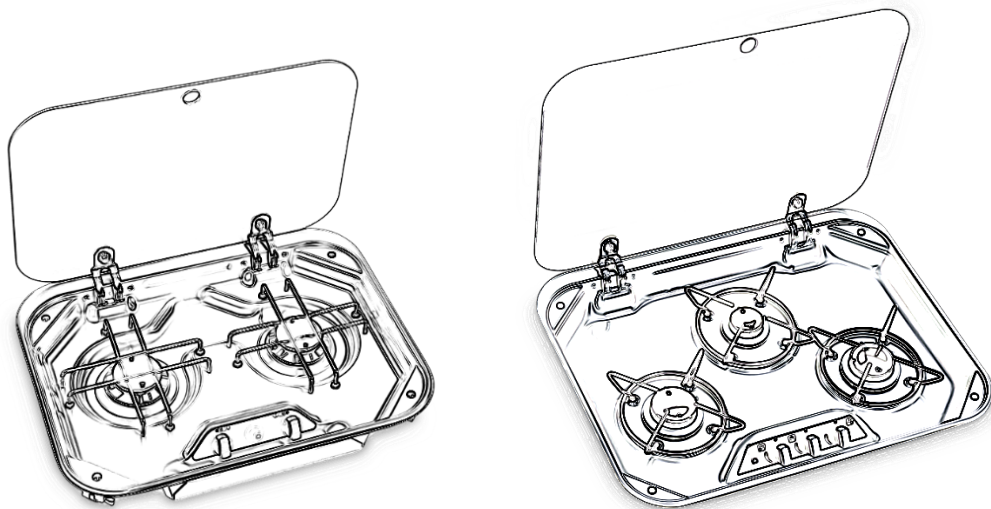

INSTALLATION, OPERATING AND MAINTENANCE INSTRUCTIONS FOR SPHERE COOKTOPS

IMPORTANT: Please carefully read this manual before using the heater. Operate strictly in accordance with the instructions & especially pay attention to " WARNINGS AND IMPORTANT NOTES ". Please store this booklet carefully after reading for future reference.

CONTENTS

WARNINGS AND IMPORTANT NOTES	2
MODELS & BENCH CUT OUTS	3
INSTRUCTIONS FOR USE	4
CLEANING AND MAINTENANCE	5
INSTALATION RECOMMENDATIONS	6
SERVICING	8
TECHNICAL SPECIFICATION	9
WARRANTY INFORMATION	9

WARNINGS AND IMPORTANT NOTES

Never leave the appliance unattended during operation. Ensure there are no children in the near vicinity during use. Make sure pot and pan handles are correctly positioned to avoid reach access by children.

Closely monitor the food being cooked at all times. Oil and grease can easily catch fire. Always keep a fire blanket and fire extinguisher nearby as a safety precaution.

This appliance must not be used by people (including children) with impaired mental or physical capacities, or without experience of using electrical devices, unless supervised or instructed by an expert adult responsible for their care and safety.

This appliance has been certified for domestic use only. Glass could shatter when exposed to excessive heat so do not use oversized or commercial size pots and pans.

If you see any cracks on the surface of the glass, discontinue use of the appliance and seek authorised repair. Children should be supervised to ensure that they do not play with the appliance.

- **DO NOT USE AN AFTERMARKET LID OR COVER.**
- **DO NOT USE OR STORE FLAMMABLE MATERIALS NEAR THIS APPLIANCE.**
- **DO NOT SPRAY AEROSOLS IN THE VICINITY OF THIS APPLIANCE WHILE IT IS IN OPERATION.**
- **DO NOT MODIFY THIS APPLIANCE.**
- **DO NOT USE THIS APPLIANCE AS A HEATER.**

IMPORTANT: Remove all transit protection before installation or before the first use.

WARNING: If the information in this manual is not followed exactly, a fire or explosion may result, causing property damage, personal injury, or death.

- Do not store or use gasoline or other flammable vapors and liquids in the vicinity of this or any other appliance.

- WHAT TO DO IF YOU SMELL GAS

- Do not try to light any appliance.
- Do not touch any electrical switch.
- Do not use any phone in your recreational vehicle.
- Clear the recreational vehicle of all occupants.
- Turn off the gas supply tank valve(s) or main gas supply.
- Immediately call your gas supplier for instructions.
- If you cannot reach your gas supplier, call the fire department.
- To test leakage of the appliance before using.

- Have the gas system checked and leakage source corrected by a qualified installer, service agency, manufacturer or dealer, or the gas supplier.

MODELS & BENCH CUT OUTS

GR-587

2 burner, rectangular insert model with glass top.
(Large is 4.15MJ/h & Small 1.6MJ/h)

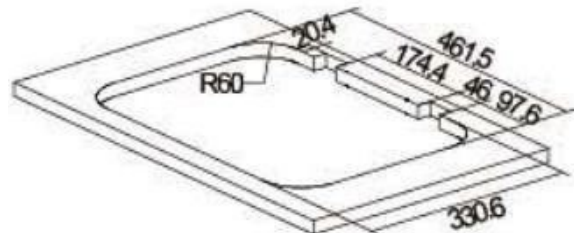

GR-888

3 burner, rectangular insert model with glass top.
(2 x Large is 4.15MJ/h & 1 x Small 1.6MJ/h)

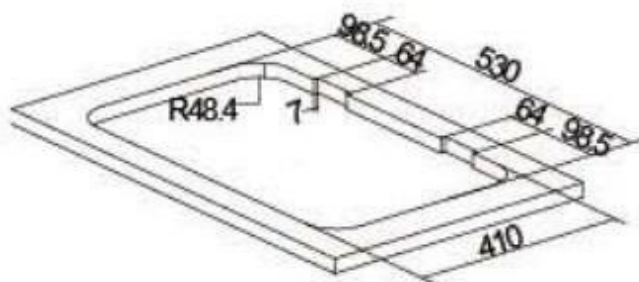

INSTRUCTIONS FOR USE

The burners are graduated in their size and rating to provide the exact heat required for each style of cooking.

All burners are equipped with FFD which means the Flame Failure Device (TC is the FFD Thermocouple in fig. 5 below). The Flame failure device will shut off the gas supply to the burner automatically if the burner flame is extinguished by wind or boil over.

All burners are also equipped with electric ignition, provided by the electrode (AC is the electrode in fig. 5 below). The ignition is actuated by either an electronic switch or via piezoelectric push button.

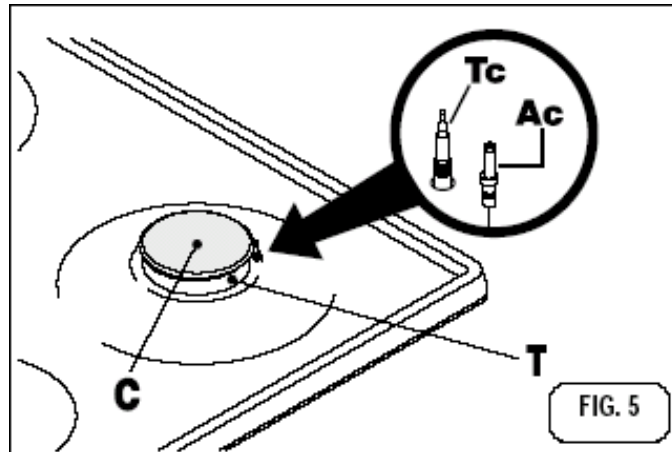

GAS BURNERS IGNITION

- The glass lid must be open when the burners are alight.
- To light a burner, select the knob corresponding to the burner you wish to use,
- The icons next to the control knobs identify each burner and its associated control knob.

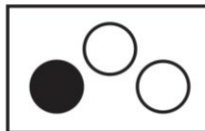

- Then press and turn anti clockwise from "Off" position to the large flame position as shown below.

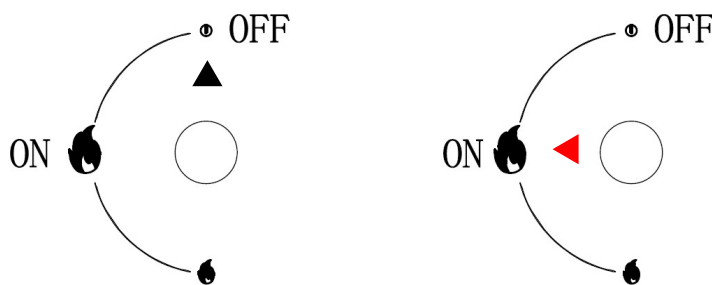

- Press the spark igniter button repeatedly until the burner ignites or if fitted with electronic ignition, press and hold the electronic igniter button until the burner ignites.
- Keep the knob pressed for 10 seconds after the burner is alight to allow the Flame Failure Device (FFD = Thermocouple) to warm up. If, at the end of this time, the burner fails to alight, it means the Flame Failure Device is not sufficiently heated. Repeat the lighting procedure.
- To turn "OFF" the burner, turn the knob clockwise to the "OFF" position

MANUAL IGNITION

Matches can be used to light the burners if necessary. To light manually, place a long, lit match next to the burner you wish to use before turning the control knob to the "Maximum" position, then follow the above steps.

To get the maximum yield with the minimum consumption of gas it is handy to keep the following points in mind:

- Once the burner is alight, adjust the flame according to your needs, from "Maximum" to "Minimum" position.
- Use proper vessel size (with flat bottom only) for each burner (see the table below and fig. 2).
- When the contents of the vessel starts to boil, turn the knob down to "Reduced rate position" (small flame).
- Put a lid on the vessel to reduce heating time.

PRACTICAL ADVICE

Practical Advice on Using the Burners:

For best performance, follow these general guidelines:

Use the appropriate cookware for each burner (see table below) in order to prevent the flame from reaching the sides of the pot or pan; Always use cookware with a flat bottom and keep the lid on; When the contents come to a boil, turn the knob to "Low"

Note: The table below is a basic guide only. Do not use large overhanging pots or cooking vessels which may transfer excess heat to the control knobs or other sensitive areas.

Burner	Ø cookware diameter (cm)
Small	10-14
Large & Wok	16-20

CLEANING AND MAINTENANCE

The stainless-steel surface of the hob, pan supports, burner caps and burner heads should be cleaned when they become tarnished. Clean with warm soapy water, rinse and then dry well to keep them in good condition.

Never clean when the top and components are still warm. Do not use metal or abrasive pads, abrasive powders or corrosive spray products. Never leave vinegar, coffee, milk, salty water, lemon or tomato juice for any length of time on the surfaces.

Comply with the following instructions, before remounting the parts:

- Check that the burner heads and burner caps, are correctly positioned before assembly.
- Check that burner head ports have not become clogged by foreign material or cooking residue.
- If any valve taps become difficult to open or close, call for technical assistance. Do not force the valve shut with tools.
- If any liquid spills over the glass top it must always be removed with a sponge.
- Use stainless steel cleaner and protector to maintain your stainless-steel top and prevent corrosion.

WARNING

Accessible parts may be hot, when the pan support is in use. Young children should be kept away.

ABNORMAL OPERATION

Abnormal operation which may require service can be identified by the following:

- A yellow burner flame
- Thick black soot on cooking utensils.
- Control knobs which are difficult to open or close.

INSTALLATION RECOMMENDATIONS

This appliance shall be installed by authorised persons only and in accordance with these installation instructions, AS5601.2, local gas fitting regulations, municipal building codes, electrical wiring regulations, local water supply regulations and any other statutory regulations.

CABINET CONSTRUCTION

For proper operation, the cabinet must:

- Be properly constructed of wood or metal, to the dimensions shown below
- The benchtop must be level.

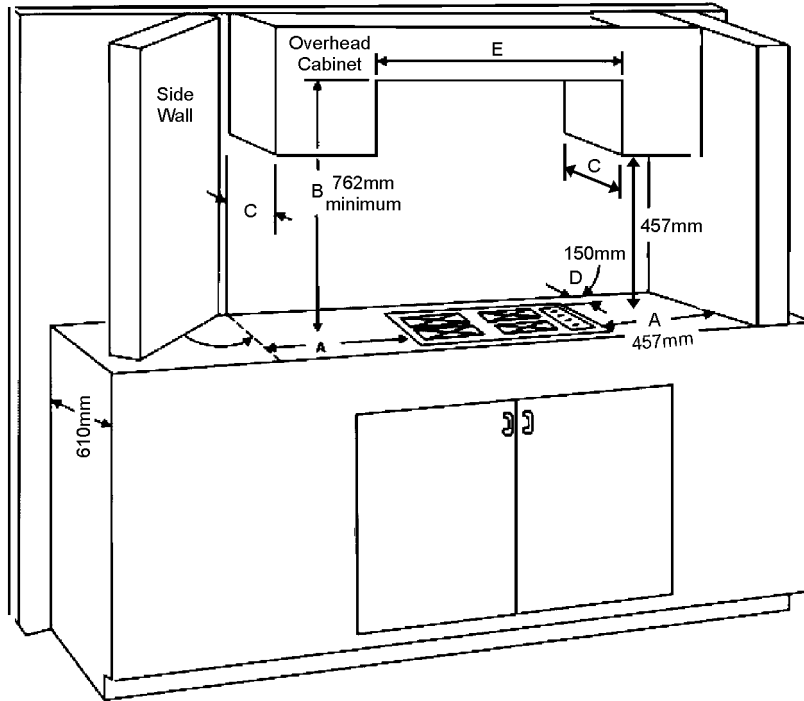

A	B	C	D	E
18.0"	30.0"	10.25"	5.9"	23.6"
457 mm	762 mm	260 mm	150mm	600 mm

Note: The height of the top of the pan support is located 15mm below the benchtop.

Any adjoining wall surface situated within 457mm from the edge of any hob burner must be a suitable non-combustible material for a height of 150mm for the entire length of the hob. Any combustible construction above the hotplate must be at least 762mm above the top of the pan supports, no construction overhanging the hob shall be within 457mm above the top of the pan supports.

BENCH CUT OUT

The hotplate is provided with a cardboard template to help the installer cut the correct shape in the benchtop.

Apply the sealing strip (where provided) to the edge of the hotplate, then lower the hotplate into the bench cut out and lock it in place with the brackets and fixing screws provided.

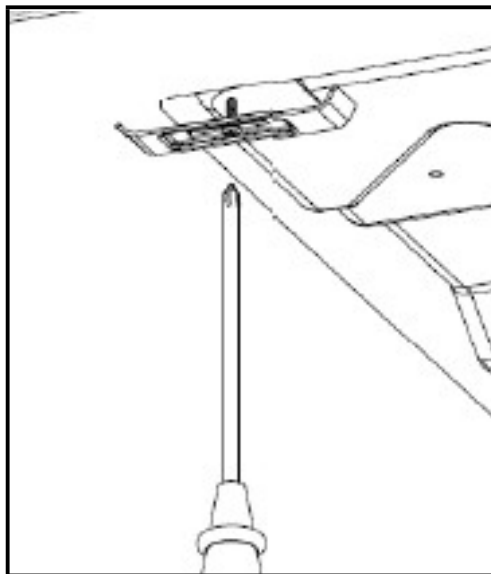

VENTILATING THE ROOMS

Ventilation must be in accordance with AS/NZS5601.2. In general, the appliance should have adequate ventilation for complete combustion of gas, proper flueing and to maintain temperature of immediate surroundings within safe limits.

INSTALLING AND FIXING THE HOB

The measurements of the cavity made in the top of the modular cabinet and into which the hob will be recessed are indicated in fig. 9. Cupboards or hoods have to maintain a least distance of 762 mm from the top.

GAS CONNECTION

The gas connection is 5/8 SAE 45° Flare male and is situated below the control knobs, and approximately 40mm below the underside of the burner mounting surface.

The hotplate can be connected to the gas supply using rigid pipe as specified in AS/NZS5601 OR

A flexible hose assembly which is AGA certified to AS/NZS 1869, 10mm ID, class B or D and the length must not exceed 1.2m. Ensure that the hose does not contact the hot surfaces of the hotplate, oven, dishwasher or other appliance that may be installed underneath or next to the hotplate.

WARNING: Ensure that the hose assembly is restrained from accidental contact with the flue or flue outlet of an under bench oven. The hose should not be subjected to abrasion, kinking or permanent deformation and should be able to be inspected along its entire length.

The supply connection point and isolating supply valve shall be accessible with the appliance installed.

In the case where a connecting hose is not easily accessible for regular inspection without the use of tools, installation with hose assembly is not permitted and the appliance must be installed using rigid pipe.

COMMISSIONING

The appliance is factory set for Universal LPG. The test point pressure shall be adjusted to 2.75kPa with the largest burner operating at maximum.

The installer must test the operation of the appliance after installation.

Where the data label is not visible in the installed position, attach the duplicate data label to an adjacent, accessible area.

BEFORE LEAVING

Check all connections in accordance with AS/NZS5601.2. Use soap and water to check for leaks, then rinse connections immediately after confirming all connections are gas tight. DO NOT use a naked flame for detecting leaks. Ignite all burners both individually and concurrently to ensure correct operation of gas valves, burners and ignition. Turn gas taps to low flame position and observe stability of the flame for each burner individually and concurrently. When satisfied, instruct the consumer on the correct method of operation. In the event the appliance fails to operate correctly after all checks have been carried out and the appliance cannot be adjusted to perform correctly, contact an authorised service person.

GAS CONVERSION

This range of hotplates are not convertible to different gas types. For use with universal LPG Only

ELECTRICAL CONNECTION

THE ELECTRICAL CONNECTION MUST BE CARRIED OUT IN ACCORDANCE WITH THE CURRENT STANDARDS AND LAWS IN FORCE.

SERVICING

Warning: Servicing should be carried out only by authorised personnel. DO NOT MODIFY THIS APPLIANCE.

We recommend the hotplate is checked annually by a licenced installer or service provider. For service and spares contact Pinnacle Wholesale on 03 5342 9651.

ANNUAL SERVICE & MAINTENANCE SCHEDULE

- Check supply pressure
- Test for leakage
- Observe flame for signs of flame abnormality
- Observe burners for deposits
- Inspect injector profiles for obstructions
- Check for satisfactory ignition
- Observe flame stability at turn down
- Check for soot deposits
- Check operation of control knobs, re-grease if required.

TECHNICAL SPECIFICATION

BURNERS INJECTORS AND CONSUMPTION RATES

Burners		Gas and pressures	Rates	Injectors diameter
no	Description	kPa	MJ/h	1/100 mm
1	Small	U- LPG at 2.75 kPa	1.6	0.40
2	Large - All models except GR-910	U- LPG at 2.75 kPa	4.15	0.60



Model No.	GR-587
Gas Type	Universal LPG
Pressure	2.75kPa
Total GC	5.75 MJ/h

	Injector/Jet	Consumption per burner
Small burner	0.40mm	1.6 MJ/h
Large burner	0.60mm	4.15 MJ/h

DOM/Serial No

DO NOT REMOVE



AUSTRALIA AND NEW ZEALAND
GAS SAFETY CERTIFICATION

Made in China



Piezo electric 28979



Gas Safety Certified

Licence Number:
SAI-400407

Standard:
AS/NZS 5263.1.1

If connected using a hose assembly, ensure the hose is restrained from contact with an under bench oven or grill. Hose must not come into contact with the hot underside of this stove. Hose must not be subjected to abrasion, kinking or contact with moving parts such as drawer runners.



Model No.	GR-888
Gas Type	Universal LPG
Pressure	2.75kPa
Total GC	9.9 MJ/h

	Injector/Jet	Consumption per burner
Small burner	0.40mm	1.6 MJ/h
Large burner	0.60mm	4.15 MJ/h

DOM/Serial No

DO NOT REMOVE



AUSTRALIA AND NEW ZEALAND
GAS SAFETY CERTIFICATION

Made in China



12VDC 28979



Gas Safety Certified

Licence Number:
SAI-400407

Standard:
AS/NZS 5263.1.1

If connected using a hose assembly, ensure the hose is restrained from contact with an under bench oven or grill. Hose must not come into contact with the hot underside of this stove. Hose must not be subjected to abrasion, kinking or contact with moving parts such as drawer runners.

WARRANTY AGAINST DEFECTS

1 WHAT THIS WARRANTY RELATES TO

1.1 This warranty covers goods supplied by Coast RV Pty Ltd T/A Coast to Coast RV Services ("Supplier") to the Client ("Goods") and relates to any defects in materials and workmanship under normal use and maintenance ("Defect").

2 WHAT THE SUPPLIER WILL DO TO HONOR THE WARRANTY

2.1 The Supplier will:

- (i) replace or repair the Goods or the defective part of the Goods free of charge;
- (ii) arrange for the Goods or the defective part of the Goods to be repaired or replaced by a qualified repairer free of charge.

2.2 The Supplier reserves the right to replace defective parts of the Goods with parts and components of similar quality, grade or composition where an identical part or component is not available.

2.3 Goods presented for repair may be replaced by refurbished goods of the same type rather than being repaired. Refurbished parts may be used to repair the goods.

3 WHAT THE CLIENT MUST DO TO CLAIM THE WARRANTY

3.1 To claim the benefit of the warranty, the Client will need to (sequentially):

- (i) first contact the Supplier; and
- (ii) present the defective Goods to the Supplier for inspection, including inspection for defective workmanship, or otherwise provide evidence of the claimed Defect, accompanied by evidence of proof of purchase and date of delivery, and if applicable, evidence of maintenance performed in accordance with the relevant maintenance schedules.

3.2 The claim listed in clause 3.1 may be made in person, or the claim may be sent to the address listed on this form, including the particulars required under clauses 3.1(i) and 3.1(ii).

3.3 The appropriate form for making a claim for warranty is as attached.

4 DURATION OF WARRANTY

4.1 This warranty will cease:

- (i) where the Goods are purchased already fitted in or as a component of a vehicle or RV: from the date that is twelve (12) months after the Client takes delivery of the vehicle or RV; and
- (ii) where the Goods are purchased separately or as an after-market item: from the date that is twelve (12) months from the date of purchase.

4.2 If a Defect does not materialise in the Goods prior to the date provided in clause 4.1, the Supplier will have no liability to the Client under this warranty.

5 RESPONSIBILITY FOR COSTS OF CLAIM UNDER THIS WARRANTY

5.1 The Supplier is responsible for the costs directly associated with repairing or replacing the Goods in accordance with clause 2.1 only.

5.2 Any works required to be completed in addition to fixing the Defect are the responsibility of the Client. Additional works includes any costs associated with any testing or repair of the Goods or any goods to which they are fitted, undertaken by a third party in relation to any defect without prior authorisation from the Supplier.

5.3 Where it is determined that the Goods do not have a Defect, the Client will be charged a GST exclusive inspection fee of forty-five dollars (\$45.00AUD in Australia or \$45.00NZD in New Zealand) plus freight costs for the return of the Goods, this is subject to change without notice.

5.4 The cost of delivery and insurance of the Goods to and from the Supplier, travel costs to and from the Supplier, and the cost of inspecting and testing the Goods are the sole responsibility of the Client.

6 WARRANTY LIMITATIONS

6.1 The Supplier makes no warranties or representations other than those set out in this warranty document except as is required by law.

6.2 The Supplier will not be liable under this warranty:

- (i) to the Client or any other person for any consequential, direct or indirect loss, damage or costs incurred or suffered by the Client or any other person, including but not limited to damage to persons, other property, loss of turnover, loss of profits, loss of business or goodwill;
- (ii) to the Client for transportation or travel costs which are the Client's responsibility;
- (iii) for damage or defects in any Goods caused by improper transportation, storage or any other misuse, neglect or accident.
- (iv) for the installation of the Goods. Any fault or defect due to installation should be referred to the installer. The Goods must be installed in accordance with the Manufacturer's instructions and any relevant legislation or code.

6.3 This warranty covers the Client only and it is not transfer able if the Goods are sold by the Client during the warranty period.

7 WARRANTY EXCLUSIONS

7.1 This warranty will not apply where:

- (i) the Goods have been improperly modified or repaired or the Good's defect has arisen due to the Client's failure to properly install, fit, maintain, service or use the Goods in accordance with the specifications and instructions provided by the Manufacturer, including a failure to comply with the relevant maintenance schedule (where applicable);
- (ii) the Supplier cannot establish any Defect in the Goods after testing;
- (iii) the Goods have been used other than for the purpose for which they were designed;
- (iv) the Goods have been subject to abnormal conditions, including but not limited to temperature, pressure, stress, load or similar;
- (v) the Client or installer have used or fitted non-genuine or non-approved parts and accessories to the Goods or have failed to use recommended parts and accessories;
- (vi) the Good's defect has arisen due to abuse, misuse, neglect or accident;
- (vii) the Goods have not been installed in accordance with the relevant instructions;
- (viii) the Good's defect is caused by use or fair wear and tear of the Goods (or expendable parts).



Distributed by:
Coast to Coast RV Services

Australian Head Office
P: +612 9645 7600
E: salesnsw@coastrv.com.au
W: www.coastrv.com.au

New Zealand Head Office
P: +614 9 274 8700
E: enquiry@coastrv.co.nz
W: www.coastrv.co.nz