

HEAVY DUTY DUAL BATTERY TRAY

Tray Fitting Instructions to suit Auxiliary battery for
Mitsubishi Pajero NM-NW

Years: 2000 onwards

Models: 4M41 DID 3.2 Litre, 6G74 3.5 Litre V6 Petrol

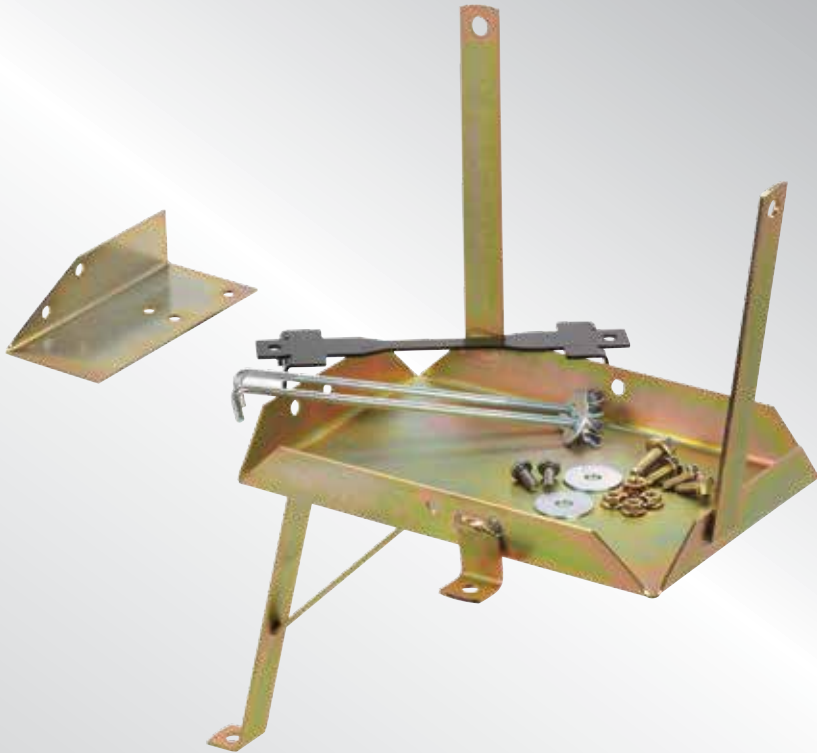

IMPORTANT SAFETY INFORMATION

Please read this instruction thoroughly before fitting the tray.

This product is recommend to be fitted by a workshop or qualified mechanical person.

WARNINGS

- Before installation, make sure that the vehicle is stationary and the wheels chocked.
- Be careful when laying wires, not to cause any electrical shorts or wire breakage.
- After installation ensure the bonnet can close without hitting the newly installed battery and battery tray.

SPECIFICATIONS

| | |
|--|--|
| Max Battery Size (mm) | L265x W174 x H220 |
| Max Battery Weight | 18Kg |
| Recommended batteries | Exide LCS 24-86 & Century NS70T |
| Approximate fitting time | 2 hours |
| Special tools | None required |
| Recommended Dual Battery System | If NW P/n: IDC25 Other vehicles can fit IDC25, DBC150 or VSR200 |
| Tray Location | Engine Bay, Passenger Side near Fire Wall |

KIT INCLUDES

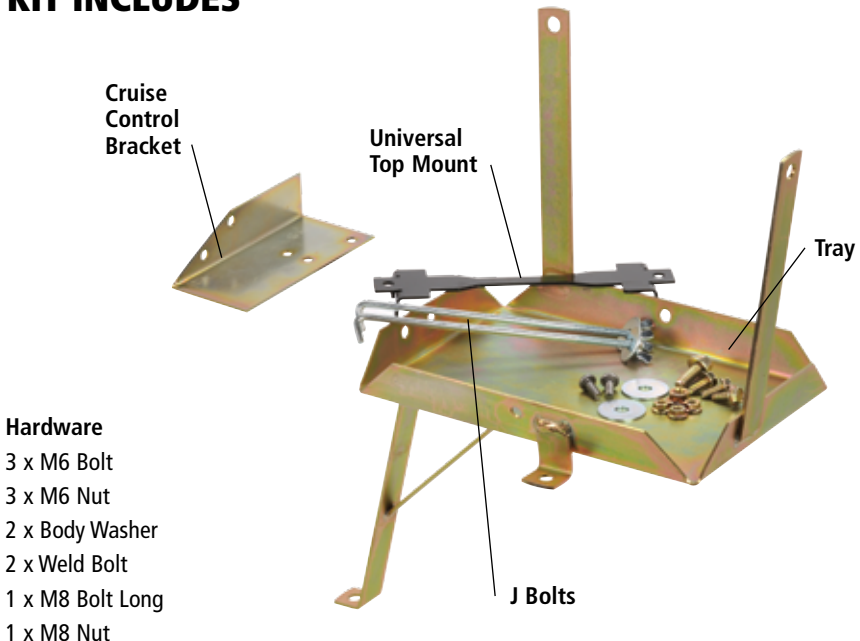

Hardware

3 x M6 Bolt

3 x M6 Nut

2 x Body Washer

2 x Weld Bolt

1 x M8 Bolt Long

1 x M8 Nut

FITTING INSTRUCTIONS

1. Make sure that the vehicle is stationary, the engine is switched off and cool. Disconnect the negative battery terminal from the main battery.
2. Early petrol models had a charcoal canister which will need to be moved to drivers side and lengthen vacuum hoses (not supplied).
3. Early petrol models will need cruise control relocated to battery with bracket and 2 x weld bolts & M6 nuts provided.
4. Bolt tray using 1 x M6 Bolt to firewall which is captive. 1 X M6 bolt with nut to drivers side of tray. 1 x M8 nut to stud at front of tray. 1 X M8 bolt and nut to inner guard with body washer. Will need to partially remove outer guard inner lining to get to bolt.



5. Fit the battery, J bolts and Universal top mount.
6. Reconnect the negative battery terminal to the main starter battery or install the desired Dual Battery System. Before closing the bonnet make sure the battery, tray and J bolts do not hit the bonnet.

For assistance throughout the installation procedure please call our customer service representatives on 1800 113 443.

WARRANTY STATEMENT

APPLICABLE ONLY TO PRODUCT SOLD IN AUSTRALIA

Brown & Watson International Pty Ltd of 1500 Ferntree Gully Road, Knoxfield, Vic., telephone (03) 9730 6000, fax (03) 9730 6050, warrants that all products described in its current catalogue (save and except for all bulbs and lenses whether made of glass or some other substance) will under normal use and service be free of failures in material and workmanship for a period of one (1) year (unless this period has been extended as indicated elsewhere) from the date of the original purchase by the consumer as marked on the invoice. This warranty does not cover ordinary wear and tear, abuse, alteration of products or damage caused by the consumer.

To make a warranty claim the consumer must deliver the product at their cost to the original place of purchase or to any other place which may be nominated by either BWI or the retailer from where the product was bought in order that a warranty assessment may be performed. The consumer must also deliver the original invoice evidencing the date and place of purchase together with an explanation in writing as to the nature of the claim.

In the event that the claim is determined to be for a minor failure of the product then BWI reserves the right to repair or replace it at its discretion. In the event that a major failure is determined the consumer will be entitled to a replacement or a refund as well as compensation for any other reasonably foreseeable loss or damage.

This warranty is in addition to any other rights or remedies that the consumer may have under State or Federal legislation.

IMPORTANT NOTE

Our goods come with guarantees that cannot be excluded under the Australian Consumer Law. You are entitled to a replacement or refund for a major failure and compensation for any other reasonably foreseeable loss or damage. You are also entitled to have the goods repaired or replaced if the goods fail to be of acceptable quality and the failure does not amount to a major failure.

Distributed by

AUSTRALIA

Brown & Watson International Pty Ltd

Knoxfield, Victoria 3180

Telephone (03) 9730 6000

Facsimile (03) 9730 6050

National Toll Free 1800 113 443

NEW ZEALAND

Narva New Zealand Ltd

22–24 Olive Road

PO Box 12556 Penrose

Auckland, New Zealand

Telephone (09) 525 4575

Facsimile (09) 579 1192