

TECHNICAL DESCRIPTION

HYDRONIC S3 ECONOMY

i **WICHTIG für den elektrischen Anschluss der Hydronic S3 CS Heizgeräte an EasyFan: Bitte beachten Sie die Hinweise in diesem Dokument (S. 33)!**
IMPORTANT NOTE for the electrical connection of Hydronic S3 CS heaters to EasyFan: Please read the reference inside this document (p. 33)!



The technical description and installation instructions are valid for these engine-independent water heaters:

	Order No.	→ 05/2020	05/2020 →
Heaters for petrol			
B 4 E – 12 V CS		20.2007.05.0000	20.2050.05.0000
B 5 E – 12 V CS		20.2008.05.0000	20.2051.05.0000
Heaters for diesel			
D 4 E – 12 V CS		25.2933.05.0000	25.2992.05.0000
D 5 E – 12 V CS		25.2934.05.0000	25.2993.05.0000
Heaters for diesel with inlet pressure resistant metering pump			
D 4 E – 12 V CS VDP		25.2943.05.0000	25.2995.05.0000
D 5 E – 12 V CS VDP		25.2942.05.0000	25.2994.05.0000

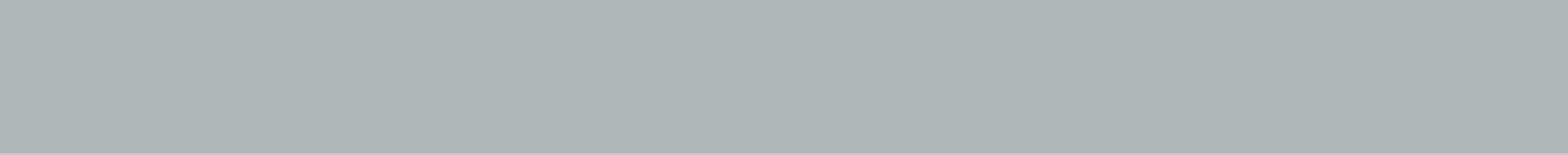

Chapter	Chapter title	Page
	Chapter contents	
1	Introduction	
	1.1 Concept of this document	6
	1.2 General information	6
	1.3 Reference documents	6
	1.4 Special text formats and presentations	6
	1.4.1 Lists	6
	1.4.2 Cross references	6
	1.5 Picture symbols	7
	1.6 Intended use	7
	1.6.1 Range of application of the heater	7
	1.6.2 Intended use of the heater (via the vehicle's own heat exchanger)	7
	1.7 Non-intended use	7
	1.8 Disclaimer	8
	1.9 Target groups of this document	8
	1.10 Duty to instruct of the target groups	8
	1.11 Statutory regulations	9
	1.12 Hazard information and warnings for installation and operation	10
	1.13 Accident prevention	10
2	Product Information	
	2.1 Order No. and scope of supply	11
	2.1.1 Petrol heater	11
	2.1.2 Diesel heater	11
	2.1.3 Heater scope of supply	11
	2.1.4 Standard installation kit scope of supply	11
	2.1.5 Scope of supply of Hydronic S3 Economy installation kit for leisure vehicles and boats	11
	2.1.6 Parts which, if required, must be ordered separately	11
	2.1.7 Connection cables / cable looms	11
	2.2 Overview – heater and installation kit	12
	2.3 Technical data	13
	2.3.1 Petrol heater	13
	2.3.2 Diesel heater	14
	2.4 Main heater dimensions	15
	2.5 Main water pump dimensions	15
3	Installation	
	3.1 Heater installation positions	16
	3.1.1 Installation position – heater upright / on its side	16
	3.1.2 Installation position – heater horizontal / vertical	16
	3.2 Water pump installation position	16

3.3	Installation location	16
3.3.1	Installation example: Petrol heater in a car	17
3.3.2	Installation example: Diesel heater in a transporter (van)	17
3.4	Mounting the heater	18
3.4.1	Installation steps	18
3.4.2	Mounting instructions for thread-forming screws	18
3.5	Mounting the water pump	18
3.6	Fix the nameplate	19
3.7	Fix the fuse holder and diagnostics connector	19
3.8	Fixing the fan relay block	19
3.9	Mounting the water socket	19
3.9.1	Installation steps	20
3.9.2	Installation instructions	20
3.10	Connection to the coolant liquid circuit	20
3.10.1	Coolant liquid circuit “inline integration”	21
3.10.2	Coolant liquid circuit “inline – engine preheating only”	21
3.10.3	Cooling liquid circuit with non-return valve and thermostat	21
3.10.4	Coolant liquid circuit with combination valve	22
3.11	Exhaust system	23
3.11.1	Installing the exhaust system	23
3.12	Combustion air system	24
3.12.1	Mounting the combustion air system	24
3.13	Fuel supply	25
3.13.1	Installing the metering pump	25
3.13.2	Preferred fuel extraction with tank connector or adapter (diesel, petrol)	25
3.13.3	Fuel extraction for heaters with inlet pressure resistant metering pump up to 2.0 bar (diesel)	27
3.13.4	Installation position of the T-piece	28
3.14	Installing the metering pump	28
3.14.1	Allowable suction and pressure head of the metering pump	28
3.15	Fuel quality for petrol heaters	28
3.16	Fuel quality for diesel heaters	29
3.17	Heating oil operation with additional tank	29

4	Operation and Function	
4.1	Operating instructions	29
4.1.1	Initial commissioning of the heater	29
4.1.2	Safety test after the summer break	29
4.1.3	Before switching on	29
4.1.4	Parking ventilation	29
4.2	Functional description	30
4.2.1	Switching on	30
4.2.2	Heating mode	30
4.2.3	Residual heat mode	30
4.2.4	Pre-heater mode following lengthy stoppage	30
4.2.5	Heating at high altitudes	30
4.3	Control and safety devices	30
5	Electrics	
5.1	Heater wiring	31
5.2	Parts list for circuit diagram for heater and cable harness, normal and ADR version	31
5.3	Heater circuit diagrams	32
5.3.1	Heater	32
5.3.2	Cable harness	33
5.4	Circuit diagrams for control units	34
5.4.1	Easy Start Pro	34
5.4.2	Easy Start Remote+	35
5.4.3	Easy Start Remote	36
5.4.4	EasyStart Web	37
6	Troubleshooting / Maintenance / Service	
6.1	Troubleshooting	38
6.2	Maintenance instructions	38
6.3	Service	38
7	Environment	
7.1	Certification	38
7.2	Disposal	38
7.2.1	Disposal of materials	38
7.2.2	Dismantling the heater	38
7.2.3	Packaging	38
7.3	EU Declaration of Conformity	38

1 Introduction

1.1 Concept of this document

This document supports the service company or installation company installing the heater and provides the user with all important information about the heater. The document is divided into the following chapters to make it easier to find information quickly:

1 Introduction

Important, introductory information about use and the structure of this document

2 Product Information

Information about the scope of supply, technical data and dimensions.

3 Installation

Information and notes concerning installation of the product

4 Operation and Function

Information on operation and function of the product

5 Electrics

Information on the electronics, circuit diagrams and components

6 Troubleshooting / Maintenance / Service

Information on possible faults, maintenance and support

7 Environment

Information about certification, disposal of the heater and the EC Declaration of Conformity

1.2 General information

This document is used to install the heaters listed on the title page and applies to the exclusion of all liability claims. The installation work may only be carried out by appropriately trained personnel of an Eberspächer service partner.

Depending on the version or revision status of the heater, differences may occur compared to this documentation. Please check this before carrying out the installation and take into account possible differences.

1.3 Reference documents

Spare parts list

Contains the information necessary for ordering spare parts.

Repair instructions

Contains the necessary information for troubleshooting and for repair of the heater.

Installation suggestion

Describes vehicle-specific installation situations.

Installation Instructions Plus

Supplementary information on heaters and control units.

1.4 Special text formats and presentations

Special text formats and picture symbols are used in these instructions to emphasise different situations and subjects. Refer to the following examples for their meanings and appropriate action.

1.4.1 Lists

- This dot (▪) indicates a list or action step, introduced by a heading.
 - If an indented dash (–) follows a “dot”, this list/action step is a sub-section/secondary step of the black dot.

1.4.2 Cross references

Underlined blue text denotes a cross-reference, which can be clicked in the PDF format. The part of the document named in the text is then displayed.

1.5 Picture symbols

Regulation!

This information indicates a statutory regulation. Any violation of these regulations results in expiry of the type-approval for the heater and exclusion of any guarantee and liability claims against Eberspächer Climate Control Systems GmbH & Co. KG.

Danger!

“Danger” indicates a situation that can directly result in death or serious injuries if not avoided.

→ This arrow indicates the appropriate measures to avert the imminent danger.

Warning!

“Warning” indicates a situation that can potentially result in death or serious injuries if not avoided.

→ This arrow indicates the appropriate measures to avert the potential danger.

Caution!

“Caution” indicates a situation that can potentially result in minor or slight injuries if not avoided.

→ This arrow indicates the appropriate measures to avert the potential danger.

Note

This note contains recommendations for use and useful tips for the operation, installation and repair of the product.

1.6 Intended use

1.6.1 Range of application of the heater

The water heater operating independently of an engine is intended for installation in the following vehicles:

- All kinds of vehicles
- Construction machinery
- Agricultural machinery

1.6.2 Intended use of the heater (via the vehicle's own heat exchanger)

- Pre-heating, de-misting windows
- Heating and keeping the following warm:
 - Driver and working cabs
 - Freight compartments
 - Passenger and crew compartments
 - Vehicle engines and units
- Residual heat heating mode (dependent on Easy Start control unit)
- Ventilation of the vehicle interior

Note

- Use with a 230 V connection to the public power system (e.g. houseboats and camper vans) only with the “CE application” installation kit.
- Only use and operate the heater within the scope of the intended use stated by the manufacturer and in compliance with the documentation enclosed with each heater.

1.7 Non-intended use

On account of its functional purpose, the heater is not approved for the following applications:

- Long-term continuous operation, e.g. for heating:
 - Residential rooms
 - Garages
 - Work huts, weekend homes and hunting lodges
 - Houseboats, etc.

Caution!

Risk of undercooling!

- The heater does not replace a temperature-monitored and controlled heating system, which ensures that a constant temperature is maintained and thus ensures survival in adverse weather conditions. It is not suitable for the continuous heating of vehicle interiors at low outdoor temperatures.
 - Use, operation and deployment of the product outside the intended use stated by the manufacturer can cause considerable injuries to people and/or damage to machinery and property.
- Only use the project for the stipulated purpose and in the approved area of use.

1.8 Disclaimer

The manufacturer is not liable for damage caused by improper use or incorrect operation. Failure to comply with the safety instructions makes the guarantee null and void and this leads to the exclusion of any liability of Eberspächer Climate Control Systems GmbH & Co. KG.

1.9 Target groups of this document

This document is aimed at the following target groups:

Service company

The “service company” target group includes all service companies trained by Eberspächer that purchase heaters and air-conditioners and their control units, accessories and spare parts from Eberspächer or the trade and install, repair or service these on behalf of an end user.

Installation company

The “installation company” target group includes all companies trained by Eberspächer that purchase heaters and air-conditioners and their control units, accessories and spare parts from Eberspächer and install, repair or service these on behalf of another company (usually the automotive / body manufacturer).

End user

The “end user” target group includes all natural persons who operate a heater or air conditioner with the help of a control unit, regardless of whether they act as a consumer or as part of their job.

1.10 Duty to instruct of the target groups

Each named target group must fulfil their duty to instruct in full. The duty to instruct relates to the passing on of technical documents.

Technical documents are all documents published by Eberspächer for the installation, operation, use, maintenance or repair of heaters and air conditioners and their control units, accessories and spare parts.

Note

- If not explicitly defined in the following, the technical documents can be passed on printed out as hard copies, on a data carrier or by internet download.
- Current technical documents can be downloaded from the Eberspächer website.

Responsibility of the installation company

The installation company must pass on the following technical documents to the company that employs them, and it in turn is obliged to pass on the documents to the end user:

- Technical description
- Operating instructions

Responsibility of the service company

The service company must pass on the following technical documents to the end user, even if they employ a subcontractor:

- Technical description
- Operating instructions

Note

The named target groups must ensure that the operating instructions produced by the manufacturer for the product are made available to the end user in printed form and in their own national language. If necessary this can be a short form of the detailed operating instructions, which are additionally enclosed with the product on a data carrier or are available to download from the internet.

1.11 Statutory regulations

The Federal Motor Transport Authority has issued an approval for a component according to ECE-R122 and ECE-R10 for the heater for installation in motor vehicles, with the following official type-approval markings noted on the heater's nameplate.

Heater type:	ECE type approval mark:
Hydronic S3	 122 R – 000449 10 R – 057330

Regulation!

Excerpt from ECE regulation No. 122 of the European Parliament and the Council

General regulations

- Operating state display
 - A clearly visible operating display in the user's field of vision must indicate when the heater is switched on and off.

Regulations concerning installation in the vehicle

Scope

- Subject to differing stipulations in the following section, combustion heaters must be installed according to the regulations 5.3 of ECE-R122.
- It is assumed that Class O vehicles with heaters for liquid fuel conform to the regulations 5.3 of ECE-R122.

Arrangement of the heater

- Parts of the structure and other components near the heater must be protected from excessive heat exposure and possible fuel or oil contamination.
- The combustion heater shall not constitute a risk of fire, even in the case of overheating. This requirement shall be deemed to be met if the installation ensures an adequate distance to all parts and suitable ventilation, by the use of fire resistant materials or by the use of heat shields.
- Do not install the heater in the passenger compartment of class M₂ and M₃ vehicles. However, a heater in a hermetically sealed enclosure which also complies with the aforementioned conditions may be used.
- Attach the nameplate, or a duplicate, so that it can be easily read when the heater is installed in the vehicle.
- Take every reasonable precaution in positioning the heater to minimize the risk of injury or damage to items carried in the vehicle.

Fuel supply

- If a separate fuel tank is used, the fuel filler neck may not be located in the passenger compartment and must be fitted with a properly closing cap to prevent any fuel leaks.
- In heaters for liquid fuel where the heater fuel supply is separate from the vehicle fuel supply, the type of fuel and filler neck must be clearly marked.
- Attach a notice to the filler neck informing that the heater must be switched off before refuelling.

Exhaust system

The exhaust outlet must be arranged so as to prevent any penetration of exhaust fumes into the vehicle interior through the ventilation system, warm air intakes or open windows.

Combustion air intake

- Do not draw the air for the combustion chamber of the heater from the passenger compartment of the vehicle.
- Position or protect the air inlet so that it cannot be blocked by objects.

Automatic control of the heating system

If the engine fails, the heating system must be switched off automatically and the fuel supply stopped within 5 seconds. The heater may remain in operation if a manual device has already been activated.

Notes

- The heater is **not** approved for installation in the driver's cab or passenger compartment of Class M₁ vehicles (vehicles for passenger transport / cars) and N vehicles (vehicles for the transport of goods).
- Compliance with the statutory regulations, the additional regulations and the safety instructions is prerequisite for guarantee and liability claims.
- Failure to comply with the statutory regulations and safety instructions and incorrect repairs, even if original spare parts are used, make the guarantee null and void and exclude any liability whatsoever of Eberspächer Climate Control Systems GmbH & Co. KG.
- The statutory regulations are binding and must also be observed in countries which do not have any special regulations.
- Subsequent installation of this heater must comply with these installation instructions.
- When installing the heater in vehicles not subject to the German Road Traffic Licensing Regulations (StVZO), the respective specially valid regulations and installation instructions must be observed.
- Installation of the heater in special vehicles must comply with the regulations applying to such vehicles.
- Further installation requirements are printed in the relevant sections of these installation instructions.

1.12 Hazard information and warnings for installation and operation

Danger!

Risk of injury, fire and poisoning!

- Disconnect the vehicle battery before starting any kind of work.
- Before working on the heater, switch the heater off and let all hot parts cool down.
- Do not start up the heater in enclosed spaces, e.g. garage or multi-storey car park.

Caution!

Safety instructions for installation and operation!

- Have the heater installed only by a service partner authorised by the manufacturer according to the instructions in this manual, possibly according to special installation recommendations; the same applies to any repairs to be carried out in the case of repairs or guarantee claims.
- Repairs by third-parties not authorised by the manufacturer and / or with non-original spare parts are dangerous and therefore not allowed. They result in expiry of the type-approval of the heater; and thus, when installed in motor vehicles, they can cause expiry of the vehicle's operating licence.
- The following measures are not allowed:
 - Changes to heating-relevant components.
 - Use of third party parts not approved by the manufacturer.
 - Installation or operation deviating from the statutory regulations, safety instructions or specifications relevant to safe operation as stated in the installation instructions and operating instructions. This applies in particular to the electrical wiring, fuel supply, combustion air system and exhaust system.
- Only use original accessories and original spare parts for installation and repairs.
- Only use the control units approved by the manufacturer to operate the heater. Use of other control units can cause malfunctions.
- Before the heater is installed again in another vehicle, rinse the heater parts carrying water with clear water.
- When carrying out electric welding on the vehicle, disconnect the positive cable at the battery and attach it to ground to protect the control box.
- Replace defective fuses only with fuses with the specified fuse rating.
- It is not permitted to operate the heater where there are readily flammable materials (e.g. dry grass, leaves, paper, etc.) in the area of the exhaust system or where ignitable fumes and dust can form, e.g. near a
 - fuel depot
 - coal depot
 - wood depot
 - grain store or similar
- Switch off the heater before refuelling.

- If the heater is fitted in a safety casing, etc., the heater's installation box must not be used as storage space and must be kept clear. In particular, do not store or transport fuel canisters, oil cans, spray cans, gas cartridges, fire extinguishers, cleaning rags, items of clothing, paper etc. on or next to the heater.
- If fuel escapes from the heater's fuel system (leak), arrange for immediate repair of the damage by an Eberspächer partner.
- Use only anti-freeze products approved by the vehicle manufacturer to top-up; please refer to the vehicle's operating manual. Blending with unapproved anti-freeze can cause damage to the engine and heater.
- Do not cancel the after-running of the heater prematurely, e.g. by pressing the battery isolating switch, except for an emergency stop.

Note

- All deviations from the safety requirements for installation and operation are to be agreed with the manufacturer in writing before they are implemented.
- Following installation, attach the "Switch off heater before refuelling!" sticker near the tank filler neck.

1.13 Accident prevention

Always follow all general accident prevention regulations and shop and operating safety instructions.

2 Product Information

2.1 Order No. and scope of supply

2.1.1 Petrol heater

Figure No.	Designation	Order No.	
		→ 05/2020	05/2020 →
1	B 4 E – 12 V CS	20.2007.05.0000	20.2050.05.0000
1	B 5 E – 12 V CS	20.2008.05.0000	20.2051.05.0000

2.1.2 Diesel heater

Figure No.	Designation	Order No.	
		→ 05/2020	05/2020 →
1	D 4 E – 12 V CS	25.2933.05.0000	25.2992.05.0000
1	D 4 E – 12 V CS VDP ¹⁾	25.2943.05.0000	25.2995.05.0000
1	D 5 E – 12 V CS	25.2934.05.0000	25.2993.05.0000
1	D 4 E – 12 V CS VDP ¹⁾	25.2942.05.0000	25.2994.05.0000

1) Heater with inlet pressure-resistant metering pump (VDP)

To be ordered separately:

Quantity	Designation	Order No.
1	Universal installation kit	25.2933.80.0000
1	Hydronic S3 Economy installation kit for leisure vehicles and boats (designed for connection to the public 230 V power system)	25.2652.82.0000
1	Control unit ¹⁾	---

1) For control unit see price list or "Product Information" document.

2.1.3 Heater scope of supply

see Fig. [on page 12](#)

Figure No.	Quantity	Designation
1	1	Heater
2	1	Metering pump
3	1	Water pump
4	1	Sensor cover
5	2	Water connection
6	2	O-ring
7	1	Screw M5 × 18
---	---	Technical documentation

2.1.4 Standard installation kit scope of supply

see Fig. [on page 12](#)

Figure No.	Quantity	Designation
8	1	Bracket, heater
9	1	Lead harness, heater
10	1	Lead harness, water pump
11	1	Tank connection
12	2	Water connection socket, 90°
13	1	Bracket
14	1	Bracket
15	1	Bracket, water pump
16	1	Flexible exhaust pipe, 900 mm long
17	1	Water hose

Figure No.	Quantity	Designation
18	1	Lead harness, fan
19	1	Exhaust silencer
20	1	Fuel pipe, 4 x 1
21	1	Combustion air intake silencer, 760 mm long
22	1	Flexible exhaust pipe end, 300 mm long
23	1	Combined bracket
24	1	Diagnostics connector
-	1 set	Cable tie
-	1 set	Fastening parts
-	1 set	Connection parts, water
-	1 set	Fastening parts, exhaust / combustion air
-	1 set	Fastening parts, electrics
-	1 set	Fastening parts, fuel
-	1 set	Fastening parts, heater

2.1.5 Scope of supply of Hydronic S3 Economy installation kit for leisure vehicles and boats

The scope of supply is identical to that of the standard installation kit; however, it is equipped with the Hydronic S3 Economy lead harness for leisure vehicles and boats. This lead harness is designed for connection of the heater to a 12 V direct voltage system, in which the connection to a public 230 V power supply system via a voltage transformer is also located.

2.1.6 Parts which, if required, must be ordered separately

Quantity	Designation	Order No.
1	Fuel filter	25.1226.89.0037
2	Adapters for the fuel filter	25.1888.80.0102
1	Kit, water circuit with thermostat	24.0347.80.0000
1	Kit, interior or engine preheating water circuit kit	24.0349.80.0000
To be purchased from the trade:		
-	Solenoid valve, 2/2 way	

2.1.7 Connection cables / cable looms

see Fig. [on page 12](#)

- A Minus supply connection
- B Diagnosis query plug connection
- C Plus supply connection
- D EasyFan module connection
- E Control units and plus supply fan relay connection
- F Minus supply fan relay
- G Activation, vehicle fan

i Note

- Parts without a figure number are small parts and are packed in a bag.
- The self-tapping screws included in the installation kit can be used for metal thickness of 2 – 6 mm (tightening torque 9⁺¹ Nm).
- Please refer to the "product information" document if any other parts are required for the installation.

2.2 Overview – heater and installation kit

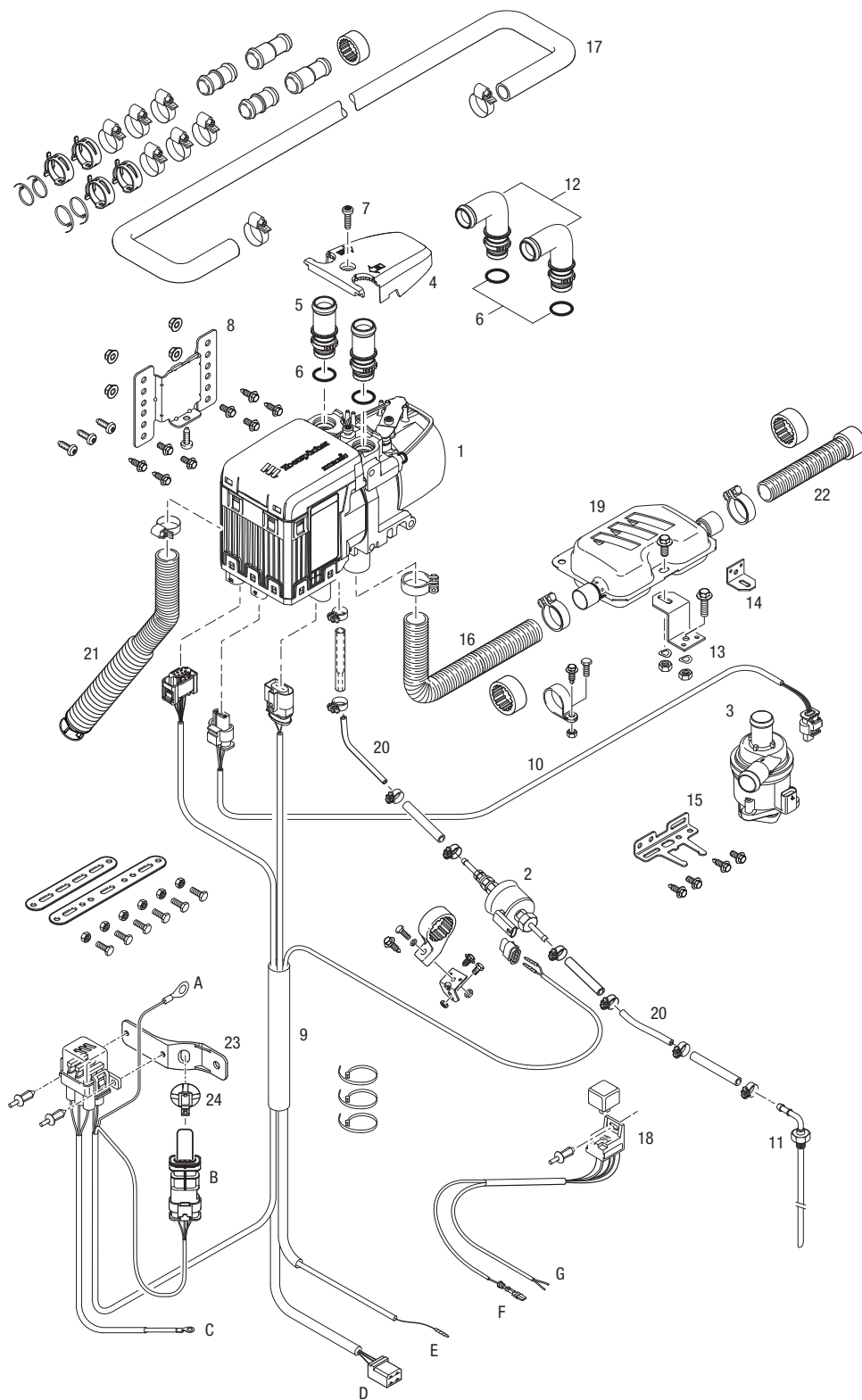

2.3 Technical data

2.3.1 Petrol heater

Heater type	Hydronic S3 Economy			
	B 4 E CS		B 5 E CS	
Heater version	B 4 E CS		B 5 E CS	
Heating medium	Mixture of water and anti-freeze (Proportion of antifreeze at least 10 % up to 50 % maximum)			
Fuel	Petrol – standard commercially available (DIN 51600 and EN 228)			
Rated voltage	12 volt			
Control of the heat flow	Maximum	Minimum	Maximum	Minimum
Heat flow (watt)	4300	1800	5000	1800
Fuel consumption (l/h)	0.57	0.23	0.67	0.23
Average electrical power consumption (watt)	during operation		while starting	
without water pump, without vehicle fan relay	24	7	32	7
Operating range	135			
Lower voltage limit: Undervoltage protection installed in the control box switches off the heater if the lower voltage limit is reached.	10.5 volt			
Upper voltage limit: Overvoltage protection installed in the control box switches off the heater if the upper voltage limit is reached.	16 volt			
Allowable operating pressure	up to 2.5 bar overpressure max.			
Water volume in the heater	approx. 0.09 l			
Minimum water flow rate of the heater	300 l/h			
Allowable ambient temperature (Also note and follow the information for installation of the heater and metering pump!)	Heater	during operation	–40 °C to +60 °C	
		not in operation	–40 °C to +105 °C, short-term +125 °C (5 x 2 h)	
	Metering pump	during operation	–40 °C to +20 °C	
		Storage drawn-in combustion air	–40 °C to +105 °C max. +25 °C, short-term +45 °C (15 minutes)	
Interference suppression class	5 (EN 55025)			
Weight – without coolant liquid and additional parts	2 kg			
Degree of protection DIN 40050, Part 9	Heater (in operation)		IP5K6K ⁽¹⁾	
	Heater (not in operation)		IP5K9K ⁽¹⁾	
Technical data, water pump				
Rated voltage	12 volt			
Nominal current	max. 1.6 A			
Nominal delivery pressure	0.2 bar			
Delivery rate	≥ 500 l/h			

1) The heater is protected against harmful quantities of dust, powerful water jet under increased pressure and water during high-pressure/steam cleaning (provided it is not in operation). The control box is dustproof, completely protected against powerful water jet under increased pressure and water during high-pressure/steam cleaning (provided it is not in operation).



Caution!

Operating the heater outside the specified technical data can cause malfunctions.

→ The technical data must be complied with at all times.



Note

Provided no other values are given, the technical data provided is with the usual tolerances of ±10 % at rated voltage, 20 °C ambient temperature and reference altitude Esslingen.

2.3.2 Diesel heater

Heater type		Hydronic S3 Economy			
		D 4 E CS		D 5 E CS	
Heater version		D 4 E CS		D 5 E CS	
Heating medium		Mixture of water and anti-freeze (Proportion of antifreeze at least 10 % up to 50 % maximum)			
Fuel		Diesel – standard commercially available (EN 590) Blending with max. 30 % FAME according to EN 14214 is permitted.			
Rated voltage		12 volt			
Working range		Maximum	Minimum	Maximum	Minimum
Heat flow (watt)		4300	1300	5000	1300
Fuel consumption (l/h)		0.53	0.15	0.59	0.15
Average electrical power consumption (watt)		during operation		while starting	
without water pump, without vehicle fan relay		27	5	32	5
Operating range		135			
Lower voltage limit: An undervoltage protection installed in the control box switches off the heater if the lower voltage limit is reached.		10.5 volt			
Upper voltage limit: An overvoltage protection installed in the control box switches off the heater if the upper voltage limit is reached.		16 volt			
Allowable operating pressure		up to 2.5 bar overpressure max.			
Water volume in the heater		approx. 0.09 l			
Minimum water flow rate of the heater		300 l/h			
Allowable ambient temperature (Also note and follow the information for installation of the heater and metering pump!)		Heater		during operation	
				not in operation	
		Metering		during operation	
		pump		not in operation	
		drawn-in combustion air		max. +45 °C, short-term +80 °C (15 minutes)	
Interference suppression class		5 (EN 55025)			
Weight – without coolant and attachments		2 kg			
Degree of protection DIN 40050, Part 9		Heater (in operation)		IP5K6K ⁽¹⁾	
		Heater (not in operation)		IP5K9K ⁽¹⁾	
Technical data, water pump					
Rated voltage		12 volt			
Nominal current		max. 1.6 A			
Nominal delivery pressure		0.2 bar			
Delivery rate		≥ 500 l/h			

¹⁾ The heater is protected against harmful quantities of dust, powerful water jet under increased pressure and water during high-pressure/steam cleaning (provided it is not in operation). The control box is dustproof, completely protected against powerful water jet under increased pressure and water during high-pressure/steam cleaning (provided it is not in operation).

Caution!

Operating the heater outside the specified technical data can cause malfunctions.

→ The technical data must be complied with at all times.

Note

Provided no other values are given, the technical data provided is with the usual tolerances of ±10 % at rated voltage, 20 °C ambient temperature and reference altitude Esslingen.

2.4 Main heater dimensions

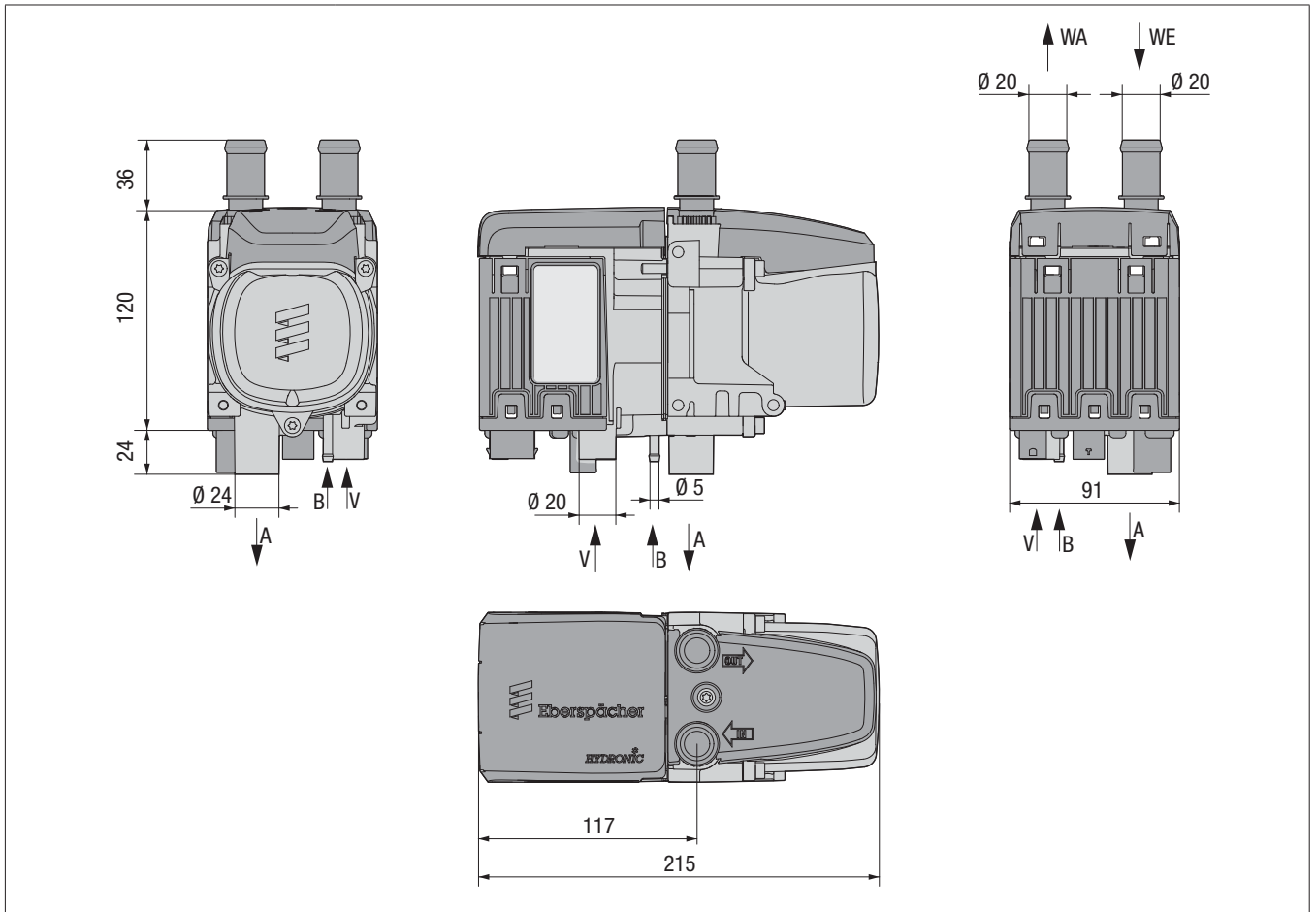

- | | |
|------------------|--------------------|
| A Exhaust | WA Water discharge |
| B Fuel | WE Water inlet |
| V Combustion air | |

2.5 Main water pump dimensions

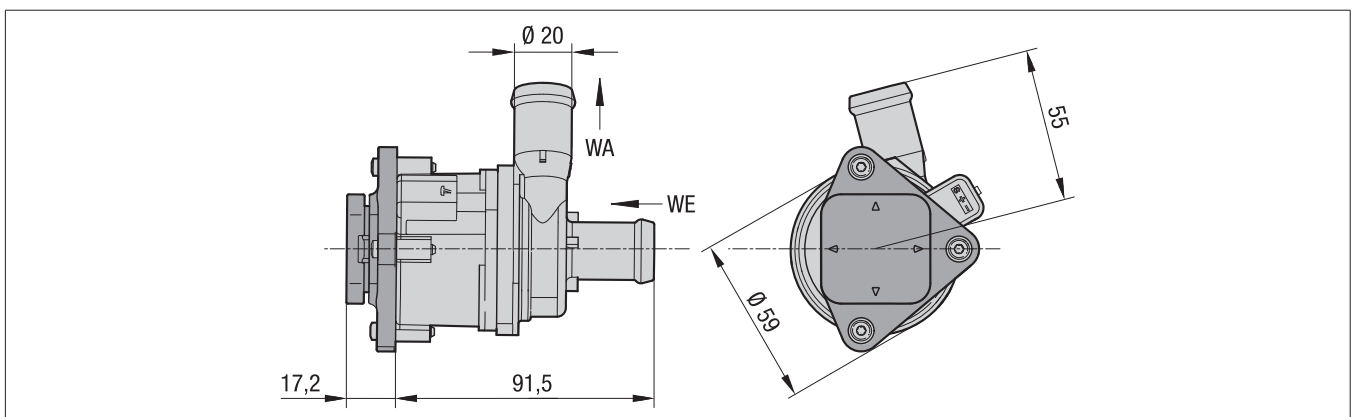

- | |
|--------------------|
| WA Water discharge |
| WE Water inlet |

3 Installation

3.1 Heater installation positions

Install the heater preferably in the normal position. Depending on the installation conditions, the heater can be installed within the allowable swivel ranges.

i Note

In heating mode, the normal and maximum installation positions shown can differ by up to +15° in all directions for a short time. These differences, caused by tilted positions of the vehicle, do not have any negative effects on the heater's function.

3.1.1 Installation position – heater upright / on its side

Allowable: The normal position (upright) with swivel range up to the horizontal installation position. All installation positions between 0° and 90° are permitted, [see Picture 1](#).

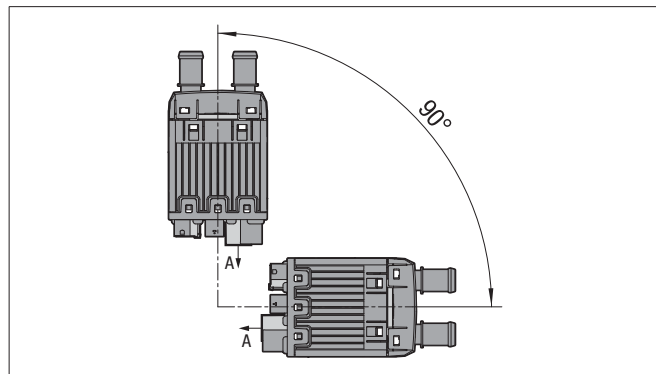

Picture 1

i Note

In case of deviations from the normal position, **always** position the exhaust connection (A) of the heater at the bottom.

3.1.2 Installation position – heater horizontal / vertical

Allowable: Horizontal installation position with swivel range up into the vertical installation position. All installation positions between 0° and 90° are permitted, [see Picture 2](#).

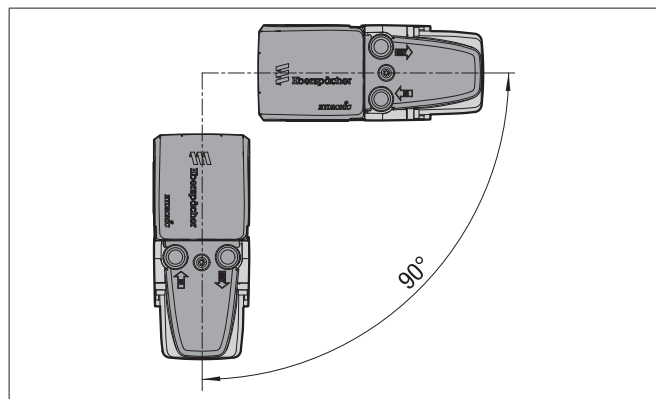

Picture 2

3.2 Water pump installation position

Depending on the installation conditions, the water pump can be installed within the allowable swivel ranges, [see Picture 3](#).

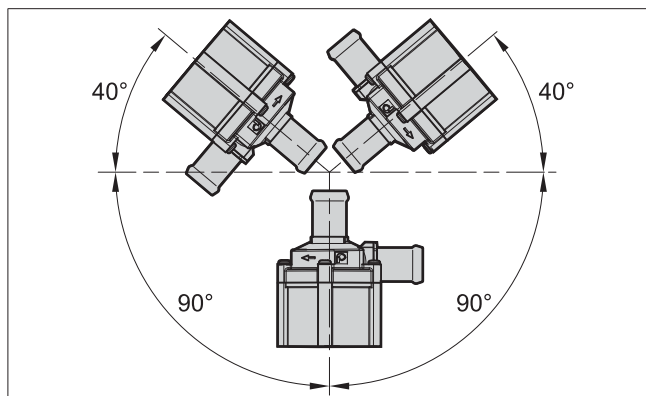

Picture 3

i Note

- The water pump is not self-priming. The water inlet must therefore be arranged so that it is always completely filled with coolant liquid.
- Installation of the water pump with the pump head facing downwards is not allowed.
- Do not mount the water pump at the lowest point of the coolant liquid circuit, as otherwise the particles in the coolant liquid circuit settle in the water pump.

3.3 Installation location

The heater and the water pump are installed in the engine compartment.

The heater and the water pump must be mounted below the minimum allowable coolant liquid level (header tank, radiator, vehicle's heat exchanger) so that the heat exchanger of the heater and the water pump can vent automatically.

i Note

- In a truck the water heater is preferably fixed onto the chassis beam underneath the driver's cab in the area of the vehicle's engine.
- Note and follow the relevant regulations and safety instructions [from page 15](#).
- The installation suggestions made in the installation instructions are examples. Other installation locations are acceptable if they comply with the installation requirements stated in these installation instructions.
- Note the operating and storage temperatures.
- Further installation information (e.g. for boats and ships) is available from the manufacturer on request.
- Ensure adequate distance from hot vehicle parts.

3.3.1 Installation example: Petrol heater in a car

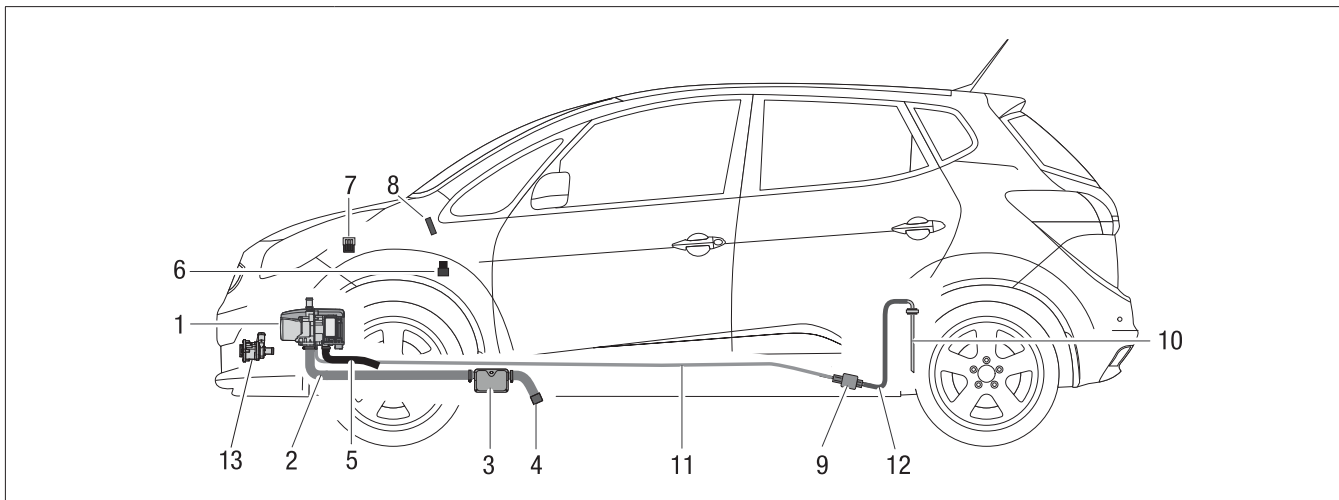

- | | | | |
|--------------------|-----------------------|--------------------|------------------|
| 1 Heater | 5 Combustion air hose | 8 Control unit | 11 Pressure line |
| 2 Exhaust pipe | 6 Fan relay | 9 Metering pump | 12 Intake line |
| 3 Exhaust silencer | 7 Fuse bracket | 10 Tank connection | 13 Water pump |
| 4 Exhaust pipe end | | | |

3.3.2 Installation example: Diesel heater in a transporter (van)

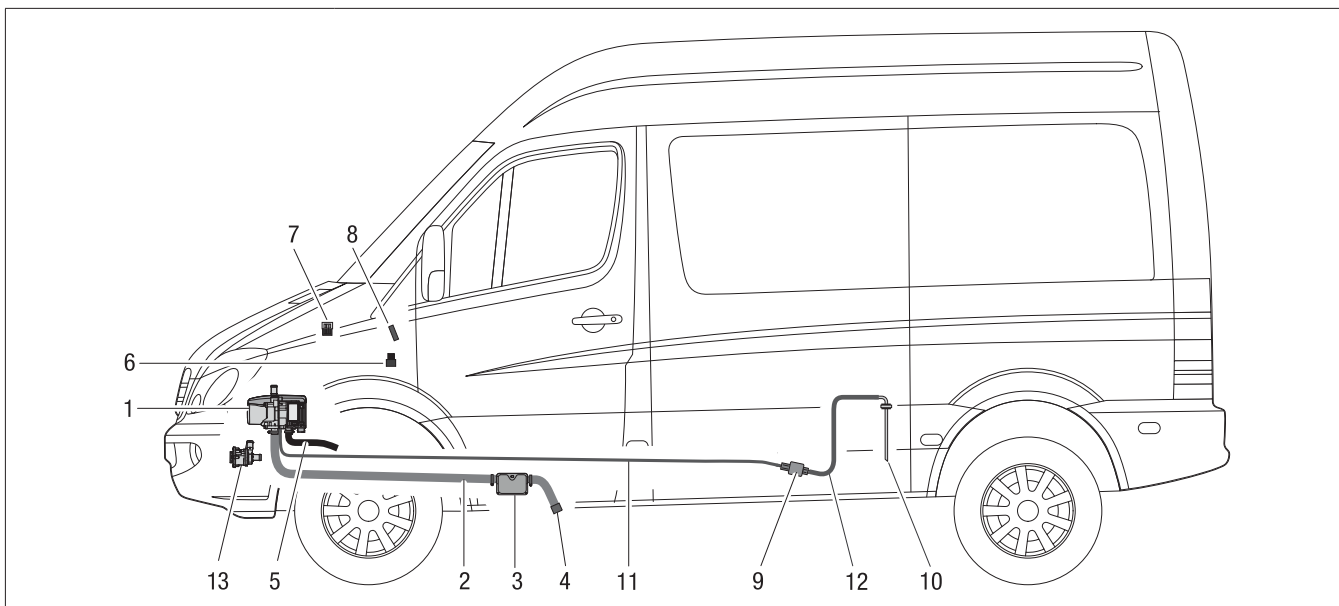

- | | | | |
|--------------------|-----------------------|--------------------|------------------|
| 1 Heater | 5 Combustion air hose | 8 Control unit | 11 Pressure line |
| 2 Exhaust pipe | 6 Fan relay | 9 Metering pump | 12 Intake line |
| 3 Exhaust silencer | 7 Fuse bracket | 10 Tank connection | 13 Water pump |
| 4 Exhaust pipe end | | | |

3.4 Mounting the heater

Use the bracket included in the installation kit to fix the heater in a suitable position on the vehicle.

3.4.1 Installation steps

- Use 4 hexagon screws M6 x 12 and 4 hexagon nuts M6 or 4 self-tapping screws 6.3 x 19 to fix the bracket (tightening torque: 9+1 Nm), [see Picture 4](#).

i Note

Mounting using self-tapping screws requires the fixing bracket to have sheet metal thickness 2 – 6 mm.

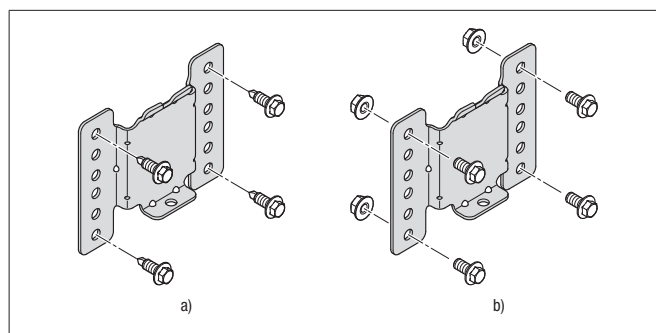

Picture 4

- Mounting using 4 self-tapping screws 6.3 x 19
- Mounting with 4 hexagon screws M6 x 12 and 4 hexagon nuts M6

i Note

Preferably use the top and bottom fixing holes, [see Picture 4](#). If using the other holes, ensure a minimum distance between the fastening screws.

- Insert the heater in the bracket and use screw M6 x 16, SW T30 to fix onto the bracket (tightening torque: 10+1 Nm), [see Picture 5](#).

i Note

- A thread-forming screw is used to fix the heater onto the standard bracket. It is not necessary to pre-cut a thread. The thread is formed by the screw on screwing it into the tapping hole.
- When installing in the vehicle, always ensure that after fixing the heater, adjacent components do not apply any force on the heater, neither under static nor under dynamic loading. Ideally, after installation a distance from adjacent components in the vehicle remains.

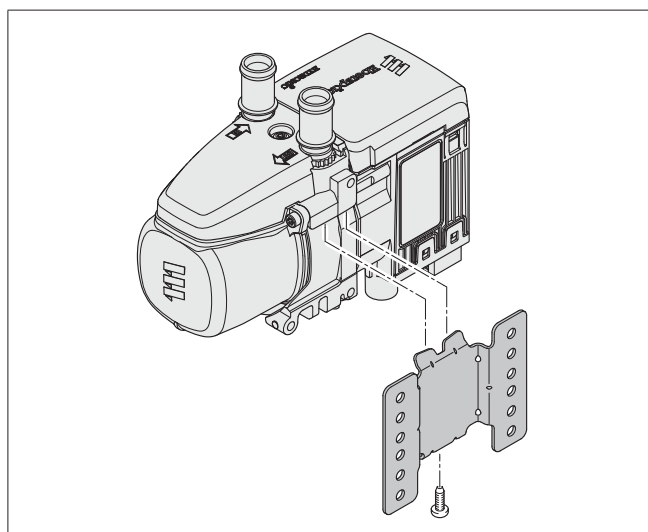

Picture 5

3.4.2 Mounting instructions for thread-forming screws

- Position screw by hand and screw in.
 - Always keep to the given tightening torque.
- When screwing for the second time also position by hand and do not cut a new thread.
- The thread-forming screw is suitable for max. 6 installation attempts.
- In case of repair (removal of heater) a metric screw (M6 x 16) can be used as an alternative.

i Note

If using a vehicle-specific bracket, note and follow the points below:

- Use the additional enclosed thread-forming screws – tightening torque: 10⁺¹ Nm)
- When fixing, ensure that no forces are exerted on adjacent components, especially not on the plastic cover of the blower/control box.

3.5 Mounting the water pump

Use the water pump bracket included in the installation kit to fix the water pump in a suitable position on the vehicle. Then insert the water pump in the rubber element and press in until the water pump has latched into position.

i Note

Use the hose and spring band clamps to connect the water pump to the water sockets of the heater. Clamping range 26 – 28 mm. If using the vehicle's own hose, check the diameter of the hose before installing.

3.6 Fix the nameplate

The nameplate (1) is fastened to the side of the heater. The second nameplate (duplicate) is enclosed with the heater and must be glued on in a clearly visible position in the vehicle, [see Picture 6](#).

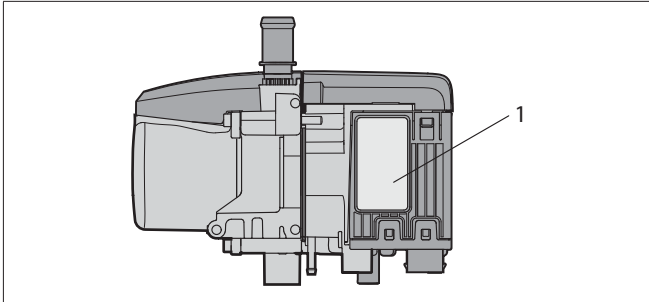

Picture 6

1 Nameplate

Note

Follow the regulations [on page 9](#).

3.7 Fix the fuse holder and diagnostics connector

- Use screw M6 to fix the combination bracket (1) in a suitable, easily accessed position in the engine compartment of fix on a stud bolt.
- Clip the diagnostics connector holder (2) into the elongated hole of the plastic bottle, [see Picture 7](#)
- Push the diagnostics connector (3) into the bracket retainer until it audibly latches into position.
- Use 2 split rivets (5) to fix the fuse holder (4). To do this, press in both bolts until the holder sits securely on the plastic bottle.

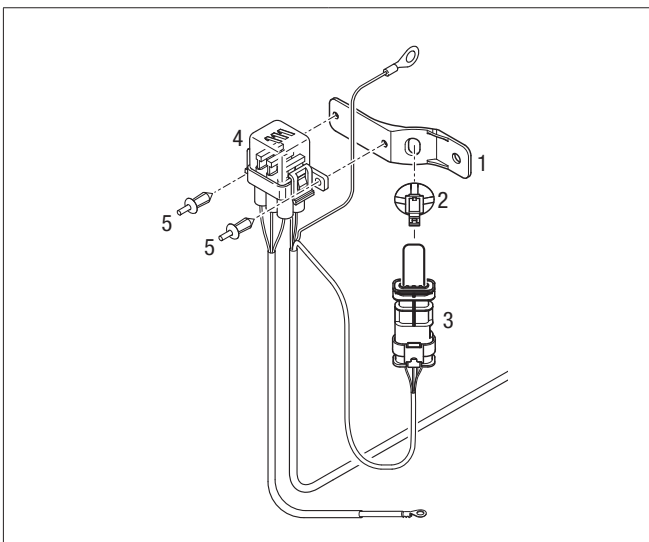

Picture 7

1 Combined bracket
 2 Retainer clip
 3 Diagnostics connector
 4 Fuse bracket
 5 Split rivet

3.8 Fixing the fan relay block

- Use cable tape or split rivet (2) to fix the fan relay block (1) in a suitable accessible place. To do this, press in the bolt of the split rivet 5.5 x 12, until the relay block sits securely, [see Picture 8](#).
- Place the cover (3) on the relay block.

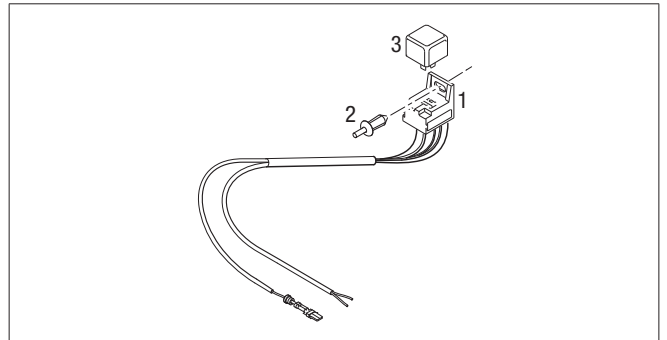

Picture 8

1 Fan relay block
 2 Split rivet
 3 Relay block cover

3.9 Mounting the water socket

- Heater scope of supply: two straight water sockets
- Installation kit scope of supply: two angled water sockets

Depending on the installation conditions, mount the straight water connection sockets (3) or the angled water connection sockets (4) together with the sensor cover, [see Picture 9](#).

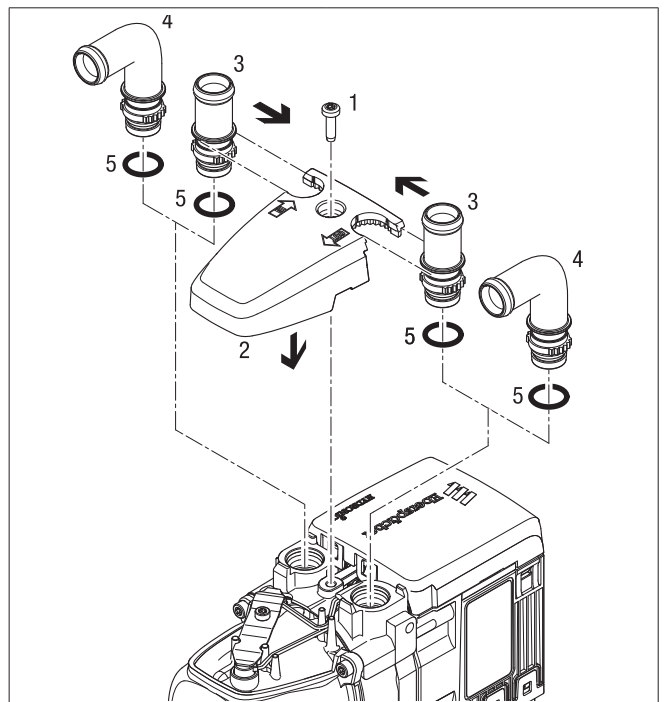

Picture 9

1 Screw M5 x 18
 2 Sensor cover
 3 Connection socket, straight
 4 Connection socket, angled
 5 O-ring

3.9.1 Installation steps

- Insert the O-rings (5) in the groove of the socket.
- Insert connection sockets (3 or 4) in the recesses of the sensor cover (2). The collar of the support is above the cover.
- Position the connection socket with teething in the sensor cover.
- Place the sensor cover with positioned socket on the heater.
- Push the connection socket completely into the connection holes in the heat exchanger.
- Adjust the direction for the angled connection sockets:
- Lift the sensor cover up to the collar of the connection sockets
- Turn connection socket in the required direction
- Push sensor cover downwards and adjust the connection socket position until the teething intermesh once again
- Use screw M5 x 18 to fix the sensor cover (tightening torque 6.5+0.5 Nm).

Note

A thread-forming screw is used to fix the sensor cover. It is not necessary to pre-cut a thread. The thread is formed by the screw on screwing it into the tapping hole.

3.9.2 Installation instructions

- Position screw by hand and screw in.
 - Always keep to the given tightening torque.
- When screwing for the second time also position by hand, do not cut a new thread.
- The screw is suitable for max. 6 installation attempts.
- In case of repair (removal of heater) a metric screw (M5 x 18) can be used as an alternative.

3.10 Connection to the coolant liquid circuit

Warning!

Risk of injury, scalding and burns

The high temperatures of the coolant liquid and the coolant liquid circuit components can cause injuries, scalds and burns.

- Before working on the coolant liquid circuit, wait until all components have cooled, wear safety gloves if necessary.
- Lay and fix parts carrying coolant liquid in such a way that they pose no temperature risk to man, animals or material sensitive to temperature due to radiation / direct contact.

The heater is integrated in the coolant liquid circuit in the water flow hose from the vehicle engine to the heat exchanger. There are various installation options for this. These are described [from page 20](#).

Note

- When installing the heater, note the flow direction of the coolant liquid in the circuit.
- Fill the heater and water hose with coolant liquid before connecting to the coolant liquid circuit.
- Lay the water hoses without any kinks, and as far as possible in a rising position.
- When laying the water hoses, maintain sufficient distance from hot vehicle parts and sharp edges.
- Protect all water hoses / water pipes from chafing and from extreme temperatures.
- Connection of the water pump to the water socket of the heater: Use enclosed hose and spring band clamps. Clamping range 26 – 28 mm. For direct connection of the vehicle's own water hose to the water pump or water socket: Check the diameter and use screw clamps if necessary
- Use screw clamps to secure other hose connections (Tightening torque: 3^{+0.5} Nm).
- After the vehicle has been operating for 2 hours or travelled 100 km, retighten the screw clamps.
- The minimum water flow rate is ensured if, at cooling water temperature > 60 °C, the temperature difference in the heating medium between the water inlet and water outlet does not exceed 10 K.
- Only overpressure valves with an opening pressure of min. 0.4 – max. 2 bar may be used in the coolant liquid circuit.
- The coolant liquid circuit must contain at least 10 % antifreeze all year round as corrosion protection.
- During cold periods the coolant liquid circuit must contain sufficient antifreeze. Follow the vehicle manufacturer's instructions regarding the mix ratio.
- Before initial commissioning of the heater or after changing the coolant liquid, the entire coolant liquid circuit including heater must be vented free of bubbles according to the instructions issued by the vehicle manufacturer.
- Only use the anti-freeze approved by the vehicle manufacturer in the allowable mix ratio (anti-freeze / water).
- Fix water hoses / water pipes securely to prevent damage and / or odour emissions due to vibrations.
Recommendation: Fix outgoing water hoses / water pipes from the heater at a distance of approx. 20 cm using hose clips, pipe clips or cable ties.

3.10.1 Coolant liquid circuit “inline integration”

- Cut the water flow hose from the vehicle engine to the vehicle's heat exchanger.
- Use connectors and water hoses to connect the heater and the water pump to the water flow hose.
- Lay a water hose from the discharge end of the water pump to the water inlet socket of the heater and connect.

Heating characteristics

If the heater is switched on, the heat is initially fed via the heater's own heat exchanger to the vehicle's engine only.

If the coolant liquid temperature has reached approx. 30 °C, the vehicle fan starts and the heat is also routed to the passenger compartment, [see Picture 10](#).

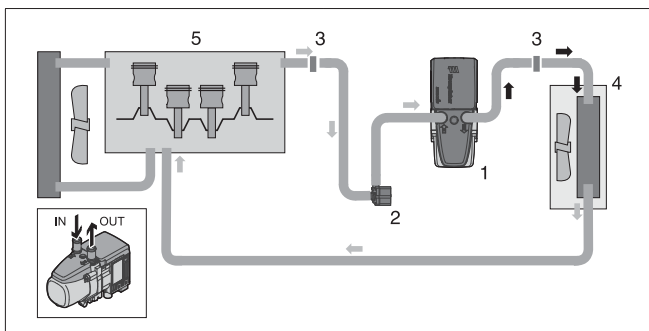

Picture 10

- | | |
|--------------|------------------|
| 1 Heater | 4 Heat exchanger |
| 2 Water pump | 5 Vehicle engine |
| 3 Connector | |

3.10.2 Coolant liquid circuit “inline – engine preheating only”

- Disconnect the water return hose from the heat exchanger to the vehicle engine.
- Use connectors and water hoses to connect the heater and the water pump.

Heating characteristics

For engine pre-heating only, set the temperature controller to “cold” and switch off the fan. There is thus no heat discharge into the interior of the vehicle, [see Picture 11](#).

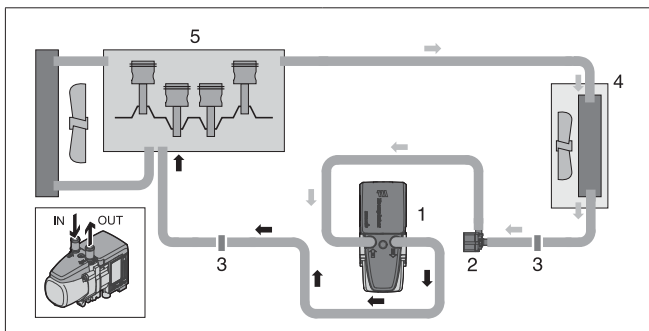

Picture 11

- | | |
|--------------|------------------|
| 1 Heater | 4 Heat exchanger |
| 2 Water pump | 5 Vehicle engine |
| 3 Connector | |

3.10.3 Cooling liquid circuit with non-return valve and thermostat

- Cut the water flow hose from the vehicle engine to the vehicle's heat exchanger and insert the non-return valve.
- Cut the water return hose from the vehicle's heat exchanger to the vehicle engine and insert the T-piece.
- Use water hoses to connect the heater and water pump to the thermostat, the non-return valve and T-piece – as shown in the sketch.

Heating characteristics – small cooling water circuit

Up to a cooling water temperature of approx. 70 °C, the heater's heat is fed first to the vehicle's heat exchanger only – fast heating of the inside of the vehicle, [see Picture 12](#).

Heating characteristics – large cooling water circuit

If the cooling water temperature continues to rise, the thermostat slowly switches over to the large circuit (full switchover is reached at approx. 75 °C) – heating of the inside of the vehicle and additional engine pre-heating, [see Picture 12](#).

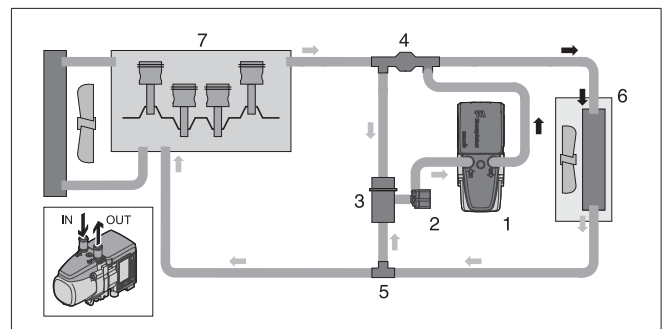

Picture 12

- | | |
|--------------------|------------------|
| 1 Heater | 5 T-piece |
| 2 Water pump | 6 Heat exchanger |
| 3 Thermostat | 7 Vehicle engine |
| 4 Non-return valve | |

i Note

The thermostat, non-return valve and T-piece must be ordered separately, please refer to the “Product information” document for the Order No.

Thermostat function

- Coolant liquid water temperature < 70 °C – small cooling water circuit:
 - Socket 1 – open (to the heater)
 - Socket 2 – open (to the T-piece)
 - Socket 3 – closed (to the non-return valve)
- Coolant liquid water temperature > 75 °C – large cooling water circuit:
 - Socket 1 – open (to the heater)
 - Socket 2 – closed (to the T-piece)
 - Socket 3 – open (to the non-return valve)

i Note

Use the connections Item (1), (2) and (3) to integrate the thermostat into the cooling liquid circuit, [see Picture 13](#).

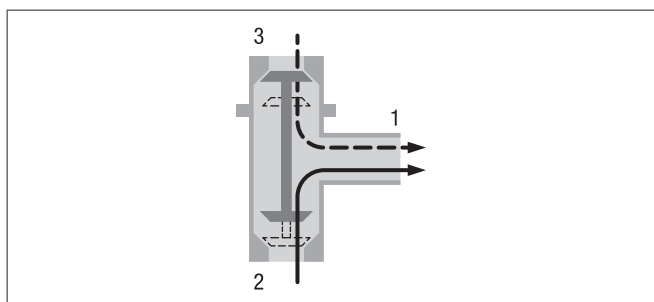

Picture 13

- | | | | |
|---|---|---|----------------------------------|
| 1 | Connection socket to the heater | 2 | Connection socket to the T-piece |
| 3 | Connection socket to the non-return valve | | |

3.10.4 Coolant liquid circuit with combination valve

Using the combination valve with 5 connections

If the water flow line and water return line from the vehicle engine to the vehicle's heat exchanger are laid separately in the engine compartment, the combination valve with 5 connections and an additional T-piece must be used.

Using the combination valve with 6 connections

If the water flow line and water return line from the vehicle engine to the vehicle's heat exchanger are laid in parallel in the engine compartment, the combination valve with 6 connections (without T-piece) must be used.

Heating characteristic in pre-heater mode – small cooling water circuit

- Up to a cooling water temperature of approx. 67 °C, the heater's heat is fed first to the vehicle's heat exchanger only – fast heating of the inside of the vehicle.
- From a cooling water temperature of approx. 67 °C, part of the heater's heat is passed to the vehicle's engine. This causes additional engine pre-heating, without rapid cooling of the "small cooling water circuit" for interior heating.

Heating characteristic in auxiliary heater mode – large cooling water circuit

While the vehicle's engine is running the heat is distributed between the vehicle's heat exchanger and the vehicle engine – further shortening of the heating up phase and heating of the inside of the vehicle, [see Picture 14](#).

Install combination valve with 5 connections

- Cut the water flow hose from the vehicle engine to the vehicle's heat exchanger and insert the combination valve.
- Cut the water return hose from the vehicle's heat exchanger to the vehicle engine and insert the T-piece.
- Use water hoses to connect the heater and water pump to the combination valve and T-piece (as shown in the sketch).

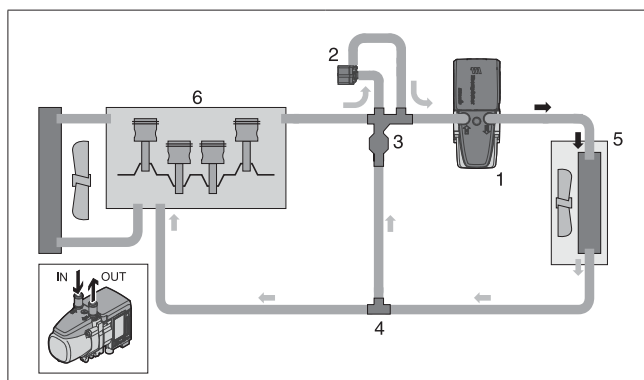

Picture 14

- | | | | |
|---|-------------------|---|------------------------|
| 1 | Heater | 4 | T-piece |
| 2 | Water pump | 5 | Vehicle heat exchanger |
| 3 | combination valve | 6 | Vehicle engine |
| | | | (5 connections) |

Install combination valve with 6 connections

- Cut the water flow hose and the water return hose from the vehicle engine to the vehicle's heat exchanger and insert the combination valve.
- Use water hoses to connect the heater and water pump to the combination valve, [see Picture 15](#).

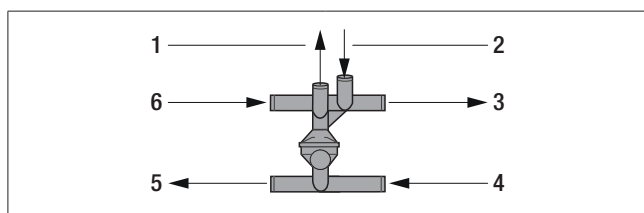

Picture 15

- | | | | |
|---|---------------------|---|-----------------------------------|
| 1 | To the water pump | 4 | From the vehicle's heat exchanger |
| 2 | From the water pump | 5 | To the vehicle engine |
| 3 | To the heater | 6 | From the vehicle engine |

Coolant liquid with 2 non-return valves

- Preheat the vehicle interior only (vehicle engine uncoupled)
- Cut the water flow hose and the water return hose from the vehicle engine to the vehicle's heat exchanger and insert one non-return valve in each.
- Insert the heater between the non-return valve and the vehicle's heat exchanger in the water flow hose.

Use water hoses to connect the water pump to the non-return valves.

Heating characteristics

If the heater is switched on, the heat is only fed to the vehicle's own heat exchanger. If the coolant liquid temperature has reached approx. 30 °C, the vehicle fan starts and the heat is routed to the passenger compartment, [see Picture 16](#).

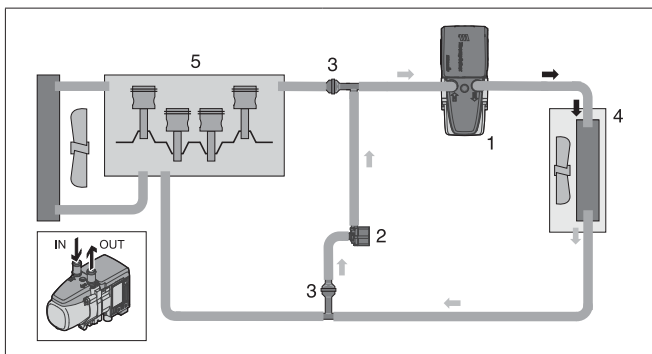

Picture 16

- | | |
|---------------------------------|--------------------------|
| 1 Heater | 4 Vehicle heat exchanger |
| 2 Water pump | 5 Vehicle engine |
| 3 T-piece with non-return valve | |

3.11 Exhaust system

Danger!

Risk of injuries and burns!

During combustion, high temperatures and toxic exhaust fumes are produced. This is why the exhaust system must always be routed as described in these installation instructions.

- Do not perform any work on the exhaust system while the heater is working.
- Before working on the exhaust system, switch off the heater first and wait until all the parts have completely cooled down, wear safety gloves if necessary.
- Do not inhale exhaust fumes.

Warning!

Risk of burns!

The entire exhaust system is very hot while the heater is running and immediately afterwards. This is why the exhaust system must always be routed as described in these installation instructions.

- The exhaust pipe must end in the open air.
- The exhaust pipe may not protrude beyond the lateral limits of the vehicle.
- Lay the exhaust pipe sloping slightly downwards. If applicable, attach a drain hole for condensate discharge at the lowest point (Ø approx. 5 mm).
- Important functional parts of the vehicle may not be impaired (maintain sufficient clearance).
- Mount the exhaust pipe with sufficient clearance to heat-sensitive parts. Pay particular attention to fuel lines (made of plastic or metal), electrical cables and brake hoses, etc!
- Exhaust pipes must be securely fixed (Recommendation: at distance of approx. 50 cm) to avoid damage due to vibrations.
- Lay the exhaust system so
 - that outflowing exhaust gases cannot be drawn into the fresh air intake of the vehicle or heater.
 - that outflowing exhaust gases cannot be drawn in as combustion air.

- The mouth of the exhaust pipe must not become clogged with dirt and snow.
- Do not mount the mouth of the exhaust pipe in the direction of travel.
- Always fix the exhaust silencer to the vehicle.
- Lay the exhaust system so that the exhaust fumes do not flow directly onto heat-sensitive components.

Note

- Follow the regulations and safety instructions for this chapter [from page 9](#).
- The exhaust pipe end should be much shorter than the flexible exhaust pipe from the heater to the exhaust silencer.
- To avoid contact corrosion, the clips for fixing the exhaust pipe must be made of stainless steel. For the Order No. of the fixing clips, refer to the “Product Information” document.

The exhaust system consists of a flexible exhaust pipe (di 24 mm), 900 mm long, a flexible exhaust end pipe with end sleeve (di 24 mm), 300 mm long and an exhaust silencer. All parts for the exhaust system including the fixing parts are included in the installation kit (for allowable line lengths, see sketch [on page 24](#)).

3.11.1 Installing the exhaust system

- Use a bracket to fix the exhaust silencer onto a suitable place on the vehicle, [see Picture 17](#).
- Lay the flexible exhaust pipe from the heater to the exhaust silencer and fasten with pipe clips (tightening torque: 6+0.5 Nm), adjust the length if necessary.
- If necessary, shorten the exhaust end pipe with end sleeve, push onto the exhaust silencer and fix with a pipe clip (tightening torque: 6+0.5 Nm).
- If necessary, use pipe clips to fasten the flexible exhaust pipe and the exhaust end pipe in suitable positions in the vehicle (Recommendation: at approx. 50 cm spacings).
- If necessary attach spacer rings on the flexible exhaust pipe and onto the exhaust pipe end, to ensure a safe distance from heat-sensitive parts of the vehicle. If applicable, use additional exhaust pipe insulation (see product information).

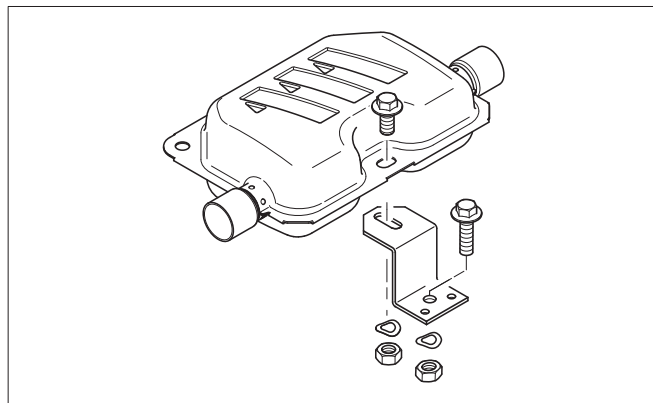

Picture 17

3.12 Combustion air system

i Note

Instructions for the combustion air system

- The combustion air opening must remain free at all times.
- Lay the combustion air inlet so
 - that exhaust gases cannot be drawn in as combustion air.
 - that fuel fumes that may occur cannot be drawn into the fresh air intake of the vehicle or heater.
- Do not direct the combustion air intake against the vehicle's air stream.
- The combustion air inlet must not become clogged with dirt and snow.
- Lay the combustion air system sloping slightly downwards. If necessary, make a drain hole of approx. \varnothing 5 mm at the lowest point to drain off condensation.
- If necessary, use fastening clips or cable ties to fix the flexible combustion air hose to the vehicle in suitable places.

3.12.1 Mounting the combustion air system

A combustion air intake silencer with a flexible pipe (di 20 mm), 760 mm long, is included in the installation kit.

- Push the flexible pipe from the combustion air intake silencer onto the combustion air connection socket of the heater and fix with a screw clamp (tightening torque $3^{+0.5}$ Nm), [see Picture 18](#).
- If necessary, shorten the flexible pipe from the combustion air intake silencer according to the installation conditions. Ensure a clean cut edge. Small cut-offs could block the combustion air fan.

i Note

Note and follow the regulations and safety instructions for this chapter [from page 9](#).

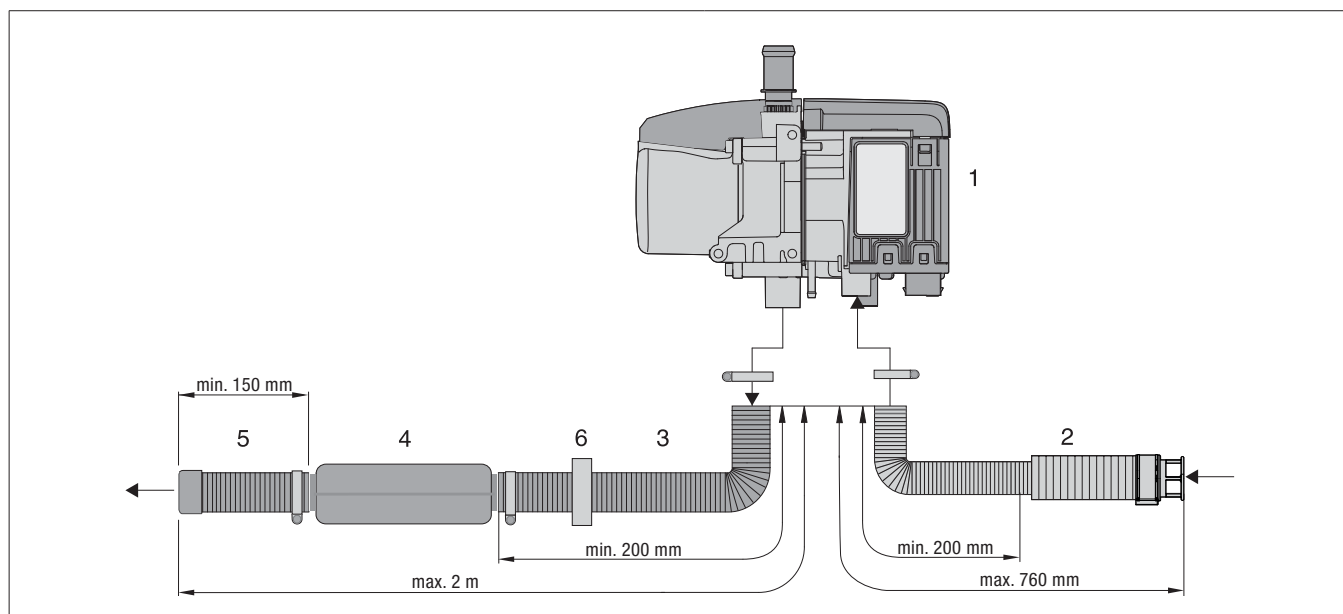

Picture 18

- | | | | |
|---|--------------------------------|---|----------------------------------|
| 1 | Heater | 4 | Exhaust silencer |
| 2 | Combustion air intake silencer | 5 | Exhaust pipe end with end sleeve |
| 3 | Flexible exhaust pipe | 6 | Spacer ring |

3.13 Fuel supply

⚠ Danger!

Risk of fire, explosion, poisoning and injury!

Caution when handling fuel.

- Switch off the vehicle engine and the heater before refuelling and before working on the fuel supply.
- No naked flames.
- Do not smoke.
- Do not inhale petrol fumes.
- Avoid any contact with the skin.

3.13.1 Installing the metering pump

⚠ Caution!

Always note and follow these safety instructions when installing the metering pump and when laying the fuel lines. Deviations from the instructions are not allowed. Failure to comply can result in malfunctions.

- To install the fuel hose at the heater, moisten it and push it carefully onto the fuel connection socket.
- Cut the fuel hoses and pipes to length at right-angles and burr-free. The cut places must not be pressed in.
- Wherever possible, lay the fuel lines from the metering pump to the heater with a continuous rise.
- Fix fuel lines securely to avoid damage and / or noise due to vibrations (Recommendation: fixing points at spacing of approx. 50 cm). Especially in electric vehicles, fix the fuel lines so that sound transfer to the vehicle is prevented.
- Protect the fuel lines against mechanical damage.
- Lay the fuel lines so that any twisting of the vehicle, engine movements, etc. do not have a disadvantageous effect on their durability.
- Use screw clamps to secure all hose connections of the fuel supply.
- Protect parts carrying fuel from interfering heat.
- Never route or fasten the fuel lines along the exhaust systems of the heater or vehicle engine.
- Where fuel lines cross the exhaust system, always ensure sufficient thermal clearance, if necessary attach heat deflection plates.
- Dripping or evaporating fuel must never be allowed to collect on hot parts or ignite on electric equipment.
- When connecting fuel lines to a fuel hose, always install the fuel lines with a butt joint to prevent any bubbles from forming, [see Picture 19](#).

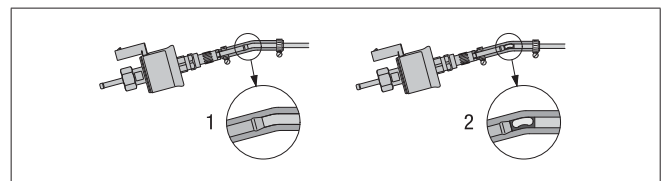

Picture 19

- 1 correctly laid lines
- 2 incorrectly laid lines – bubbles form

⚠ Caution!

Safety instructions for fuel lines and fuel tanks in buses and coaches!

- Fuel lines and fuel tanks must not be located in the passenger compartment or driver's cab.
- Mount the fuel tank in the vehicle so that the normal passenger exits and emergency exits are not at risk in the event of a fire.

i Note

- The installation kit contains all parts required for the fuel supply.
- Follow the regulations and safety instructions for this chapter [from page 9](#).
- Sound insulation and abrasion protection: Sponge rubber hose for fuel lines available separately as an accessory (see product information).

3.13.2 Preferred fuel extraction with tank connector or adapter (diesel, petrol)

⚠ Caution!

Fuel supply safety instructions!

The fuel must not be conveyed by means of gravity or overpressure in the fuel tank.

- The fuel may only be pumped by the metering pump included in the scope of supply and approved by the manufacturer.

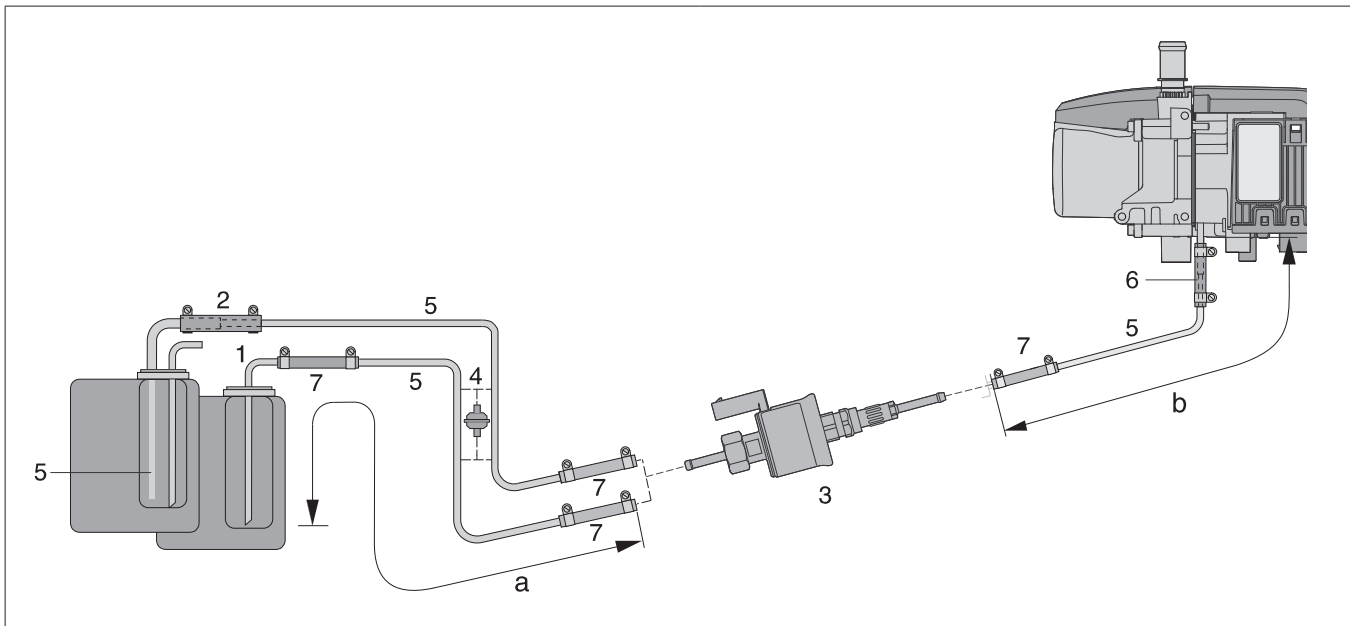

Picture 20

- | | |
|---|---|
| <p>1 Tank connection (di = Ø 2 mm, da = Ø 4 mm) – installed in the vehicle's own tank fitting</p> <p>2 Adapter (Ø 7.5 / 3.5 mm) – connected to the vehicle's own tank fitting, at a socket Ø 8 mm, used to pass through the intake line (fuel pipe 4 x 1) up to just before the bottom of the tank.</p> | <p>3 Metering pump</p> <p>4 Fuel filter – only required for contaminated fuel</p> <p>5 Fuel pipe, 4 x 1 (di Ø 2 mm)</p> <p>6 Adapter (Ø 4.5 / 3.5 mm)</p> <p>7 Fuel hose, 3.5 x 3 (di Ø 3.5 mm), approx. 50 mm long</p> |
|---|---|

Permissible line lengths

Intake side: a = max. 2 m

Pressure side: b = max. 6 m

Note

Fuel supply mounting instructions, see Picture 20

- Items 4 and 5 are not included in the “Universal installation kit” scope of supply. Order No. [see page 11](#).
 - Connect fuel pipe (Item 5) to the heater using adapter (Item 6). The adapter (Item 6) with diameter 4.5 mm fits on the fuel sockets of the heater. The smaller diameter 3.5 mm fits on the fuel pipe.
-
- Use two screw clamps Ø 11 to secure the adapter Ø 7.5 / 3.5 mm (Item 2) (tightening torque: 1^{+0.2} Nm).
 - Installation of a fuel filter (Item 4) requires two adapters Ø 5 / 3.5, Order No. [see page 11](#).
 - When installing tank connection (Item 1), maintain a minimum distance of 5^{±2} mm from the end of the riser to the bottom of the tank.

3.13.4 Installation position of the T-piece

Keep to the installation positions shown when inserting a T-piece, see [Picture 22](#).

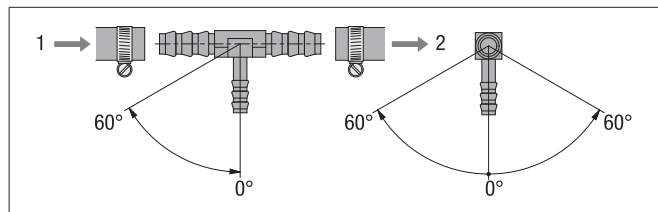

Picture 22

- 1 Direction of flow – to the fuel tank
- 2 Direction of flow – from the vehicle engine

3.14 Installing the metering pump

i Note

Metering pump installation instructions!

- Always install the metering pump with the delivery side rising upwards – minimum angle 15°.
- Do not install the metering pump and filter near silencers and exhaust pipes and therefore protect against unacceptable heating (petrol max. 20 °C, diesel max. 50 °C).
- Always install the metering pump with the delivery side rising upwards. Any installation position between 15° and 90° is allowed.
- Preferred installation position: between 15° and 35°, see [Picture 21](#).

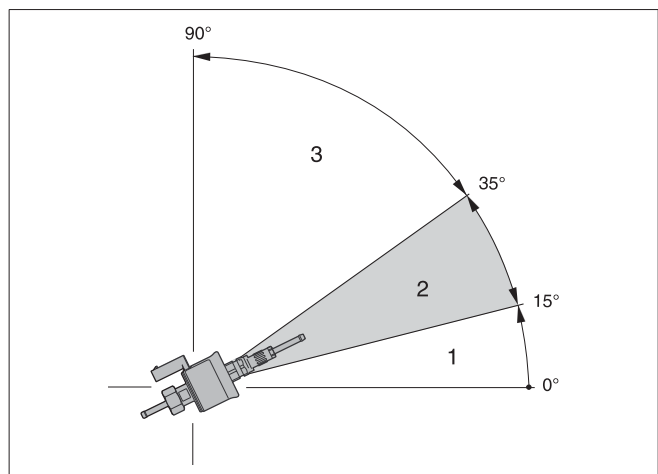

Picture 23

- 1 Installation position between 0° – 15° is not allowed
- 2 Preferred installation position within the range 15° – 35°
- 3 Installation position within the range 35° to 90° is allowed

3.14.1 Allowable suction and pressure head of the metering pump

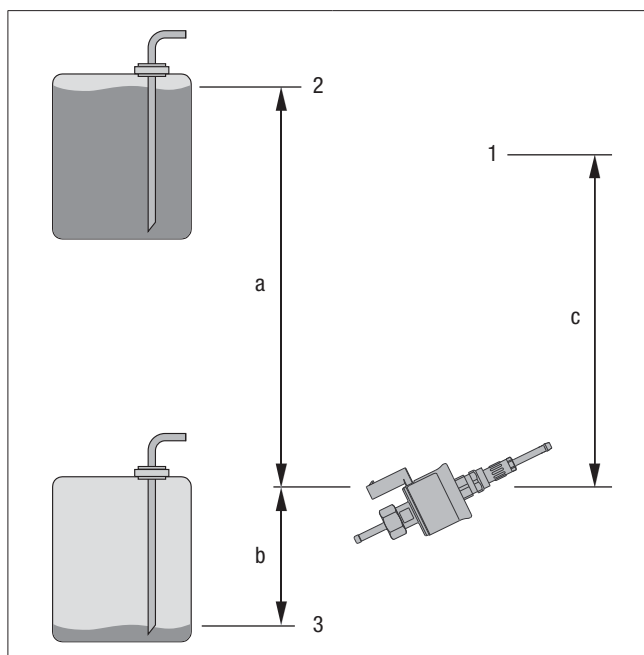

Picture 24

- 2 max. fuel level
- 3 min. fuel level
- 1 Connection at the heater

Pressure head from vehicle tank to metering pump:

a = max. 3000 mm

Suction head in pressure-less vehicle tank:

b = max. 500 mm for petrol
b = max. 1000 mm for diesel

Suction head in a vehicle tank in which negative pressure occurs during extraction (valve with 0.03 bar in the tank cap):

b = max. 150 mm for petrol
b = max. 400 mm for diesel

Pressure head from the metering pump to the heater:

c = max. 2000 mm

i Note

After mounting the metering pump, check tank ventilation.

3.15 Fuel quality for petrol heaters

The heater runs problem-free on standard commercial quality fuel, which you use to run your vehicle engine. Commercially available, maximum blending of ethanol to DIN 51600 and EN 228.

i Note

The heaters B 4 E and B 5 E are **not** approved for operation with ethanol fuel E85 to DIN 15293.

3.16 Fuel quality for diesel heaters

The heater runs on standard commercial grade diesel fuel to EN 590 with max. 30 % biodiesel content (FAME). In case of storage periods longer than 30 days it is advisable to use FAME-free products, as ageing effects can have a negative effect on the fuel, especially regarding its flow properties and filterability.

During the winter months the diesel fuel is adapted to the low temperatures of 0 °C to -20 °C. This means that problems can only arise if extreme drops in temperature occur – as is the case for the vehicle engine too – please refer to the vehicle manufacturer's instructions.

3.17 Heating oil operation with additional tank

In special cases and at outside temperatures above 0 °C the heater can also be run on EL heating oil according to DIN 51603 (from an additional tank).

If the heater is run from a separate tank, please comply with the following rules:

- at outside temperatures above 0 °C: use diesel fuel to EN 590 or EL heating oil to DIN 51603;
- at outside temperatures of 0 °C to -20 °C: use winter diesel fuel to EN 590;
- at outside temperatures of -20 °C to -40 °C: use Arctic diesel or polar diesel.

i Note

- It is **not** permitted to add used oil!
- Following operation with winter or cold diesel, the fuel lines and the metering pump must be filled with the standard diesel fuel after letting the heater run for 15 minutes!
- Heaters B 4 E and B 5 E are **not** approved for operation with biodiesel to DIN 14214.

4 Operation and Function

4.1 Operating instructions

The heater is operated by a control unit. Detailed documentation / CD for operation is enclosed with the control unit.

i Note

The service company or installation company gives the documentation / CD to the end user.

4.1.1 Initial commissioning of the heater

i Note

Slight smoke and/or odours can develop during the initial commissioning of the heater. This is completely normal during the first minutes of operation and is not an indication of a malfunction.

The following points are to be checked by the company installing the heater during **initial commissioning**.

- Following installation of the heater, vent the cooling water circuit and the entire fuel supply system carefully. Comply with the instructions issued by the vehicle manufacturer.
- Open the coolant circuit before the trial run (set the temperature control to "WARM").
- During trial running of the heater, check all water and fuel connections for leaks and tight fit.
- If faults occur while the heater is running, use a diagnostic unit to determine and correct the cause of the fault.

4.1.2 Safety test after the summer break

- After a lengthy stoppage (summer months), check all components for secure fit (tighten screws where necessary).
- Carry out a visual check of the fuel system for leaks.

4.1.3 Before switching on

Before switching on or pre-programming heating mode, switch the vehicle's heating controller to "HOT" (maximum setting) and the fan to "slow level" (low electricity consumption). In vehicles with automatic heating, before switching off the ignition, switch the heating control to "MAX" and the required damper position to "OPEN".

4.1.4 Parking ventilation

Parking / cab ventilation means: possible activation of the vehicle fan directly via the control unit or – even more useful – via the radio remote control by bypassing heating mode, in order to ventilate the often over-heated vehicle interior in the summer with fresh air just before driving away.

4.2 Functional description

4.2.1 Switching on

When the heater is switched on, the  symbol appears in the control unit or the operating display lights up.

4.2.2 Heating mode

- The water pump starts up and, following a preset sequence, the combustion air fan, glow plug and metering pump are started.
- The glow plug is switched off once a stable flame has formed in the combustion chamber.
- Depending on the heat requirement, the heater adjusts continuously between the heating outputs: MAX – MIN – OFF (pause mode). The temperature thresholds for these are permanently programmed in the electronic control box.

If the coolant liquid is cold the heater starts in “Max” control stage. If the water temperature rises to 75 °C (water outlet temperature of the heater), the heater adjusts the heat output continuously depending on the heat removed (heat requirement), in order to keep the water outlet temperature at a constant 75 °C. The heater provides the exact heat output required, if this is between the “MAX” and “MIN” control stages.

- If the heat output of the heater in control stage “MIN” is higher than the removed heat (heat requirement) and the water temperature rises to 85 °C, the heater adjusts to control stage “OFF” (pause mode) and then starts the after-run.
- If the water temperature cools to 70 °C during pause mode, a controlled start follows in “MIN” control stage. The heater now adjusts the heat output continuously, depending on the removed heat, between the “MAX” and “MIN” control stages. During pause mode the water pump continues to run and the On symbol  continues to be displayed in the control unit.

4.2.3 Residual heat mode

In this mode the heating system uses the residual heat in the cooling water circuit of the hot engine and distributes the heated air in the vehicle interior. In this mode only the water pump and blower are in operation.

Note

The residual heat mode function is possible in conjunction with the Easy Start Pro control unit.

4.2.4 Pre-heater mode following lengthy stoppage

Following a lengthy stoppage (e.g. summer break) it is recommended that you switch on the heater once while the vehicle engine is running and cold. The empty fuel lines are filled quickly; the next start of the heater (pre-heater mode) can take place without problems.

4.2.5 Heating at high altitudes

When using the heater at high altitudes, please note:

- Heating at altitudes up to 1500 m:
 - Unlimited heating possible.
- Heating at altitudes over 1500 m – 3000 m:
 - The heater can be run for short periods (e.g. driving through a mountain pass or taking a break in your journey).
 - In case of a lengthy stay, e.g. winter camping, fault-free heating mode cannot be guaranteed.

Note

If the Easy Start Pro control unit is used, the altitude must be adjusted manually for the activated heater. See Easy Start Pro operating instructions.

4.3 Control and safety devices

- If the petrol heater does not ignite within 105 seconds of switching on (diesel heater: 70 seconds), the start is repeated. If the heater does not ignite within the specified safety time (240 seconds), a safety shut-down occurs. After an unacceptable number of failed start attempts, the control box is locked*.
- If the flame goes off by itself during operation, the heater is restarted. If the heater does not ignite or ignites but goes out again within 10 minutes, a safety shutdown occurs. The safety shut-down can be cancelled by briefly switching off and on again (heater ON / OFF).
- In the event of overheating (e.g. lack of water, poorly ventilated coolant liquid circuit) the overheating sensor triggers. The fuel supply is interrupted and a safety shut-down occurs. Once the cause of the overheating has been eliminated, the heater can be restarted by switching it off and on again (heater ON / OFF). Requirement: The heater is sufficiently cooled (water temperature < 70 °C). After a maximum of 10 shutdowns on overheating, the control box is locked*.
- If the lower or upper voltage limit is reached, the heater is shut down automatically.
- The heater does not start up if the glow plug is defective or if the electric cable to the metering pump is interrupted.
- The speed of the fan motor is monitored continuously. If the fan motor does not start up, if it is blocked or if the speed falls below 40 % of the set speed, a safety shutdown occurs after 60 sec.

Note

Do not repeat the switching off / on routine more than twice.

*) * Cancellation of the lock or reading out of the fault memory is possible:

- with the Easy Start Pro control unit.
- with the EasyScan diagnostics tool.
- with the EasyStart Web operating software

For operating details and error list, refer to the “Troubleshooting and Repair Instructions” of the heater and/or the “PLUS–Easy Start / Altitude Kit Installation Instructions, Special Functions and Diagnosis”.

Emergency stop – EMERGENCY OFF
 If an emergency stop – EMERGENCY OFF – is necessary during operation, please complete the following steps:

- Switch the heater off at the control unit or
- remove the fuse or
- disconnect the heater from the battery.

5 Electrics

5.1 Heater wiring



Warning!

Safety instructions for wiring the heater!

Connect the heater electrically according to the EMC directives.

EMC can be affected in case of interventions not carried out properly. For this reason, comply with the following instructions:

- Ensure that the insulation of electrical cables is not damaged.
- Avoid: Chafing, kinking, jamming or exposure to heat.
- Seal any connector chambers of watertight connectors not in use with filler plugs to ensure they are dirt-proof and watertight.
- Electrical connections and ground connections must be free from corrosion and securely connected.
- Lubricate connections and ground connections outside the heater interior with contact grease.



Note

- Position electric cables and components in the vehicle so that they can function perfectly under normal operating conditions without impairment (e.g. due to heat exposure, moisture, etc.).
- Keep to the specified cable lengths and cable cross-sections of the positive cable 4² and the negative cable 2.5² between the battery and the heater. This ensures that the maximum allowable voltage drop in the cables does not exceed 0.5 V for 12 V rated voltage.
- If the cable (positive cable + negative cable) is lengthened up to 6 m, the next-higher cable cross-section must be selected.
- If the positive cable is to be connected to the fuse box (e.g. terminal 30), the vehicle's cable from the battery to the fuse box must also be included in the calculation for the total cable length and re-dimensioned if necessary.
- Insulate unused cable ends.
- The 12 volt relay (-K1, from terminal 30 to terminal 87a) has a maximum current carrying capacity of 40 A; i.e. the value of the vehicle's own fan fuse may not be more than 40 A. Circuit diagram [see page 32](#).

5.2 Parts list for circuit diagram for heater and cable harness, normal and ADR version

- A10 Hydronic S3 Economy 12 V control box
- A30 Fuse holder 3-pin
- B5 Flame sensor
- B10 WAF
- B11 WEF
- F1 Fuse, heater
- F2 Fuse, control unit
- F3 Fan relay fuse
- K1 Fan relay
- M3 Burner motor
- W1 Cable loom, water pump
- W2 Cable loom, metering pump
- M10 Water pump
- R1 Terminating resistor I
- R2 Terminating resistor 120 Ω
- R3 Terminating resistor, stub line 9.2 kΩ
- X1 Ring terminal end
- XB1 Bush housing, heater power supply
- XB2 Bush housing, heater signals
- XB3 Bush housing, heater water pump
- XB6/1 EasyScan bush housing
- XB6/3 EasyFan bush housing
- XB6/4 Bush housing, control unit
- XB7 Relay block
- XB8/1 Bush housing, metering pump plug-in connection
- XB8/2 Bush housing, water pump
- XS6/1 Mating connector with terminating resistor
- XS8 Connector housing, metering pump plug-in connection
- Y1 Fuel metering pump

- a to the heater
- b Activation, vehicle fan
- c to the control unit
- x insulate and tie back any cables that are not needed

Cable colours

RD	red	GR	grey	BK	black
BU	blue	YE	yellow	GN	green
WH	white	VT	violet	BN	brown

5.3 Heater circuit diagrams

5.3.1 Heater

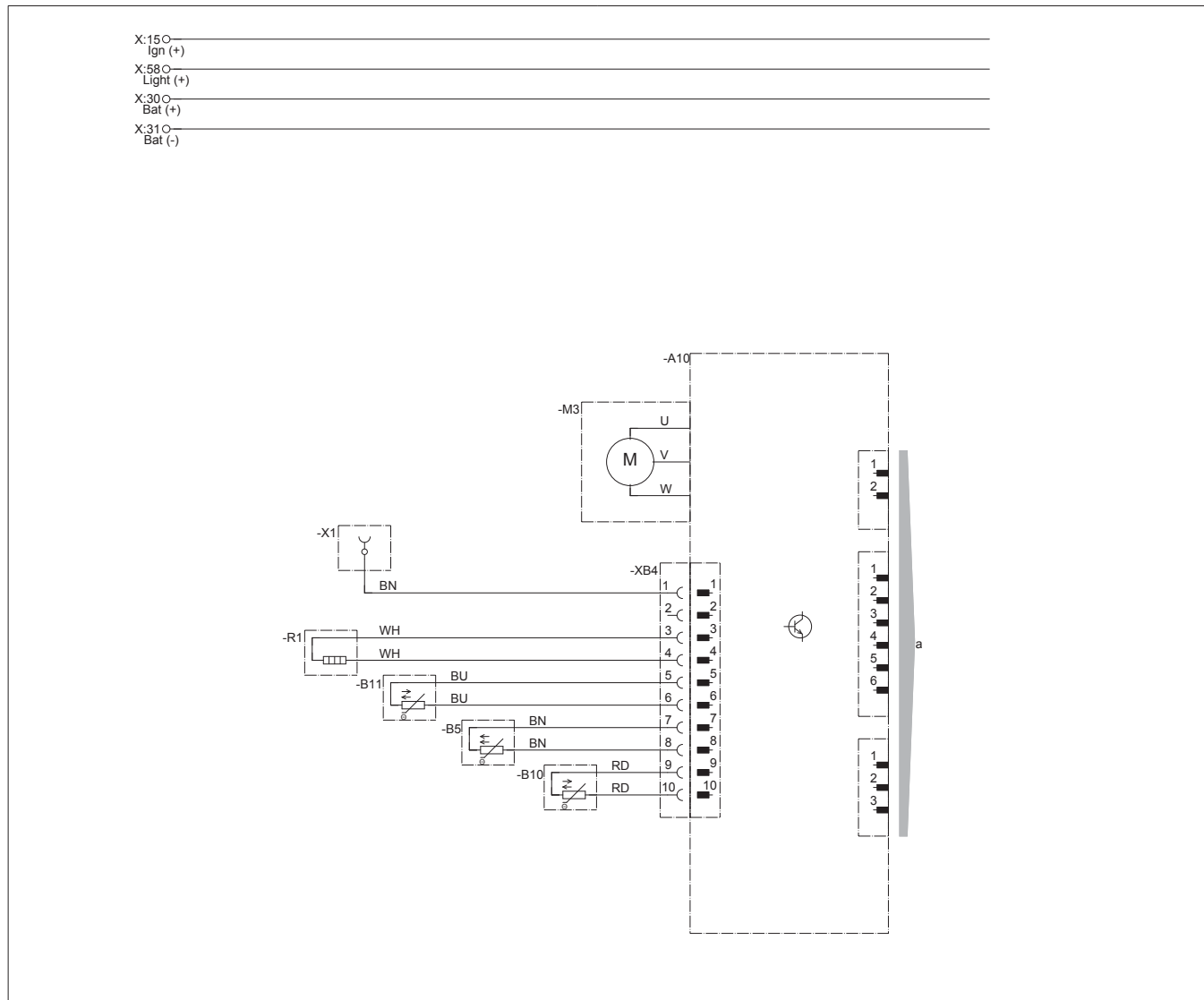

Parts list [see page 31](#)

25.2691.00.9601.0A

5.3.2 Cable harness

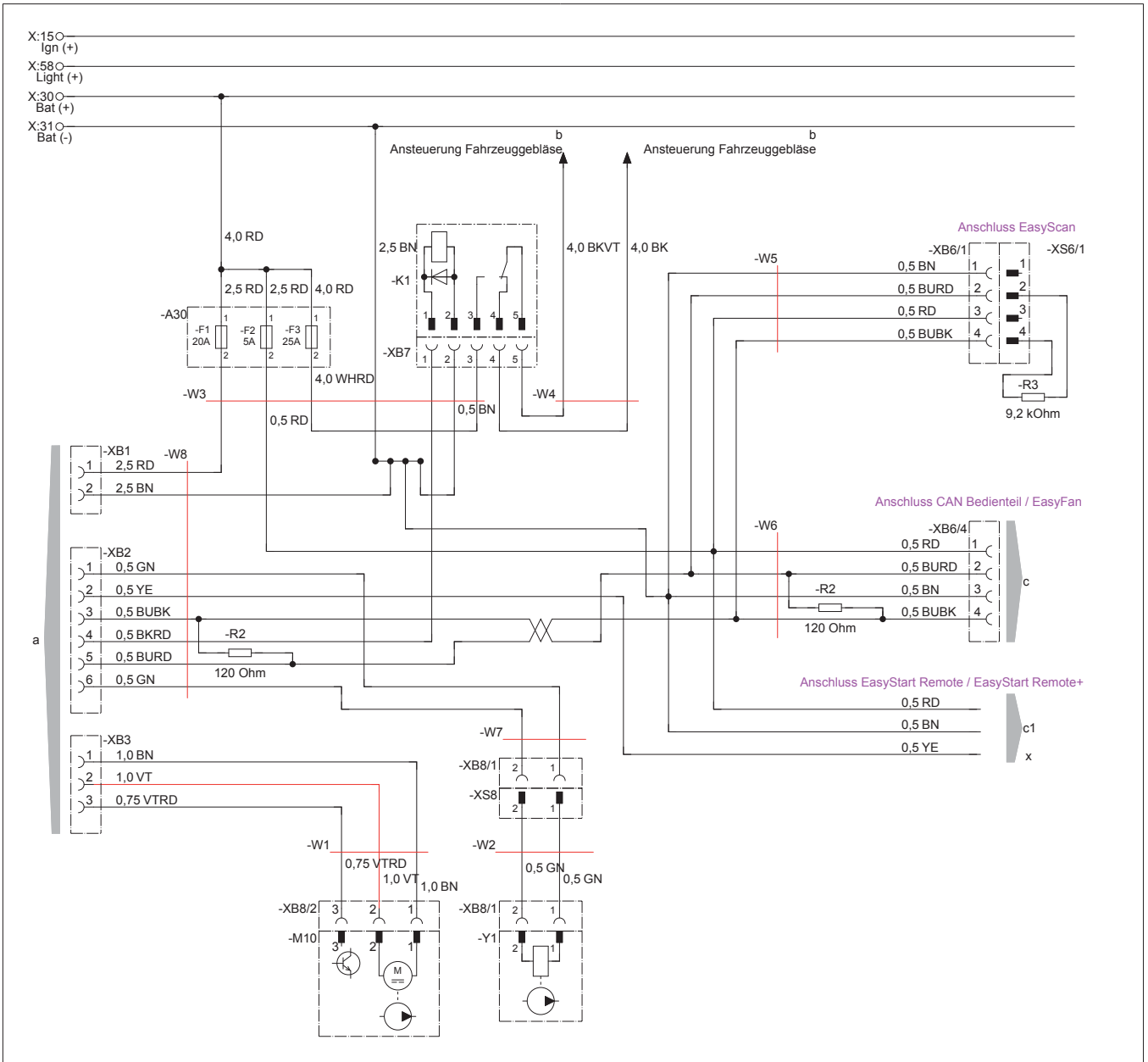

Parts list [see page 31](#)

25.2691.00.9602.0A

i Note

Use the Y-cable 22.1000.25.2800 (not included) to connect EasyFan to the heater. The cable disconnects the CAN connection to EasyFan, as EasyFan does not communicate with CAN-capable heaters and control units.

- Connect the 4-pin connector of the heater lead harness to the Y-cable.
- Connect the 4-pin connector of the Y-cable to the EasyFan control box.
- Connect the BKRD cable of the heater lead harness (fan output) to the BKRD cable of the EasyFan control box lead harness (8-pin connector, PIN 7).

5.4 Circuit diagrams for control units

5.4.1 Easy Start Pro

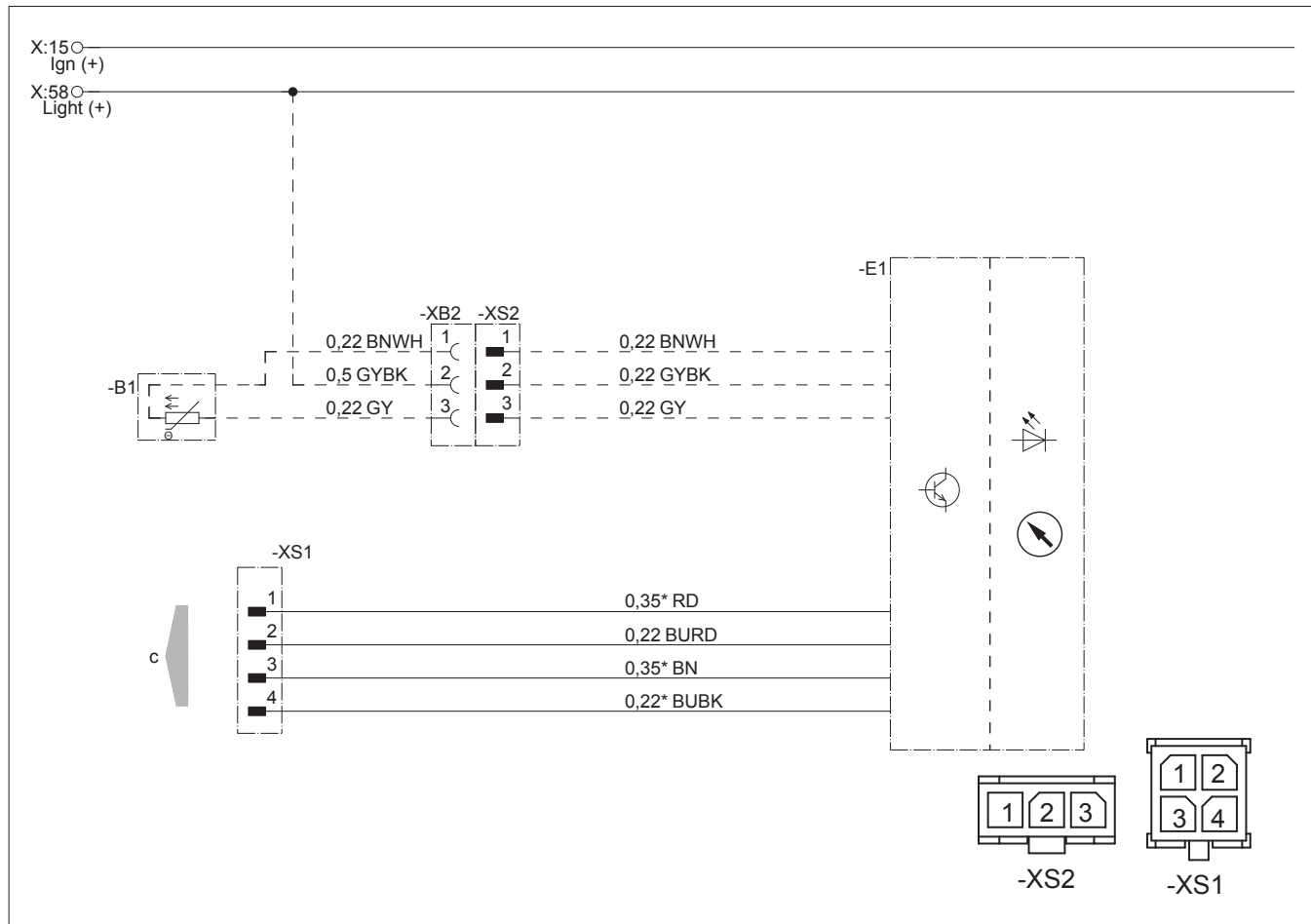

22 1000 34 97 22

Parts list

- B1 Room temperature sensor
- E1 Easy Start Pro
- c to the heater cable harness

Connectors and bush housings are shown from the cable inlet side.

i Note

Further circuit diagrams for the Easy Start Pro are printed in the Installation Instructions Plus; these are available to view and download from the Service Portal.

5.4.2 Easy Start Remote+

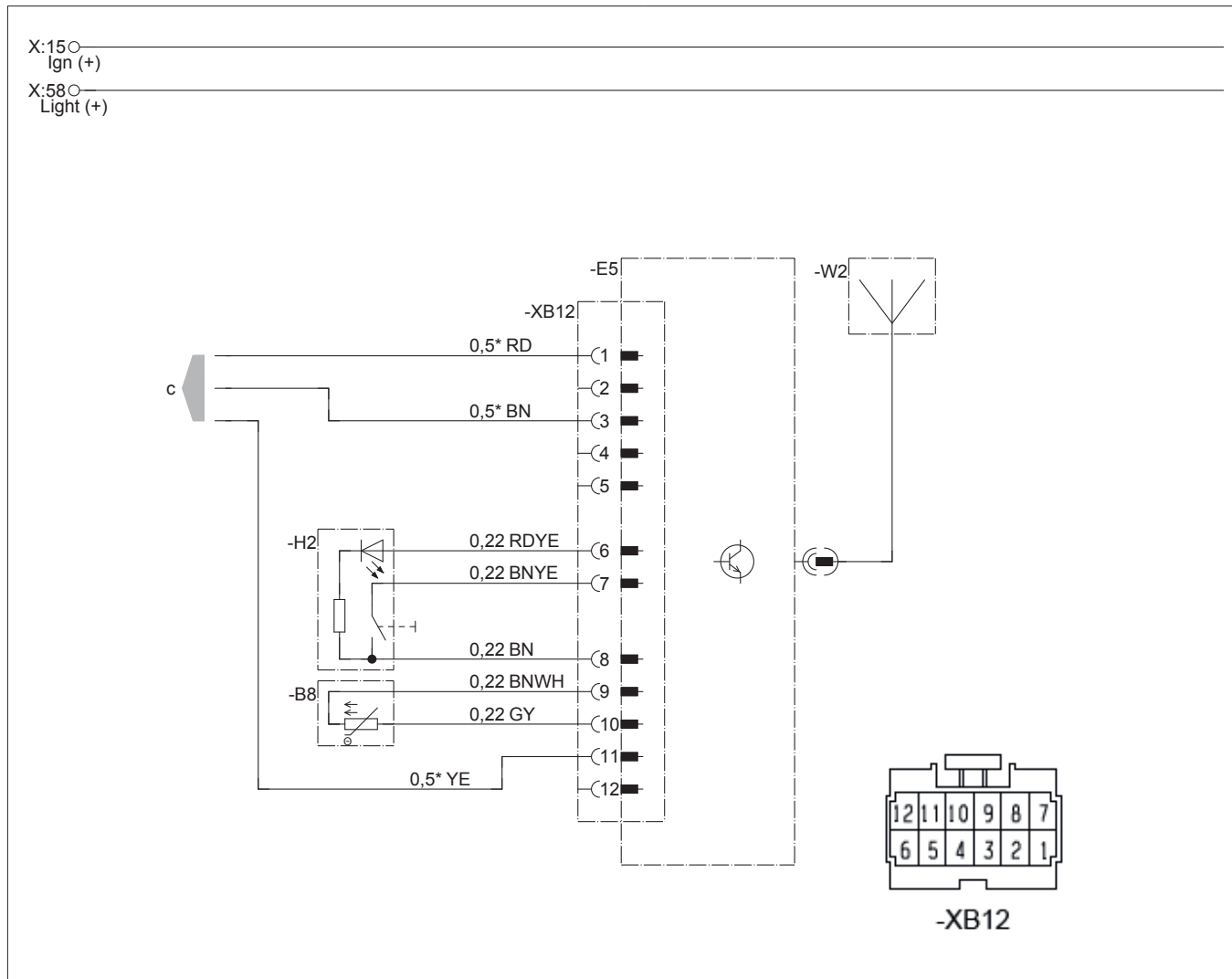

22 1000 35 97 02

Parts list

- B8 Room temperature sensor
- E5 Stationary unit, EasyStart Remote+
- H2 Button
- W2 Antenna
- c to the cable harness

Connectors and bush housings are shown from the cable inlet side.

Note

Further circuit diagrams for the EasyStart Remote+ are printed in the Installation Instructions Plus, these are available to view and download from the Service Portal.

5.4.3 Easy Start Remote

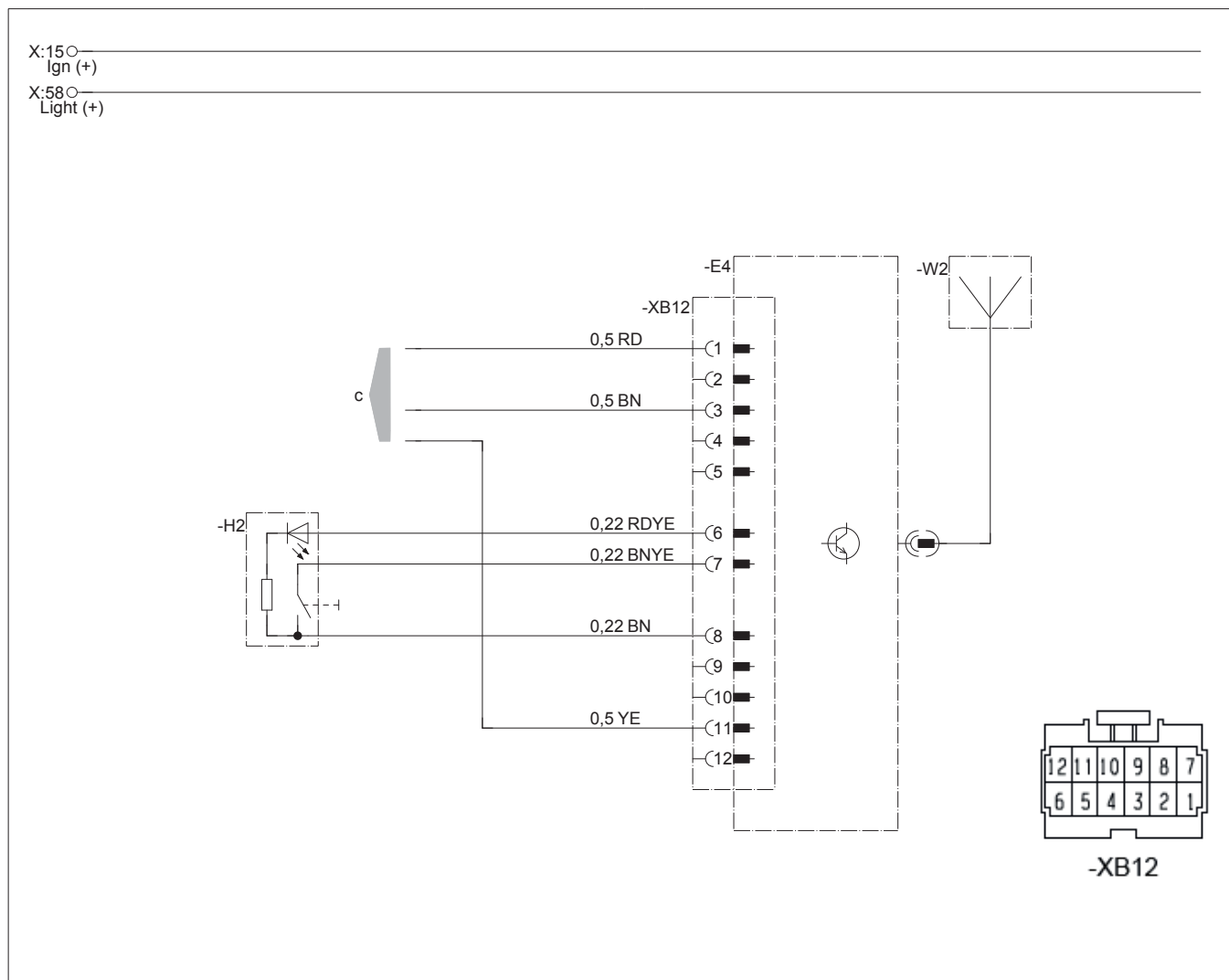

22 1000 35 97 01

Parts list

- E4 Stationary unit EasyStart Remote
- H2 Button
- W2 Antenna
- c to the cable harness

Connectors and bush housings are shown from the cable inlet side.

Note

Further circuit diagrams for the Easy Start Remote are printed in the Installation Instructions Plus. They are available to view and download in the Service Portal.

5.4.4 EasyStart Web

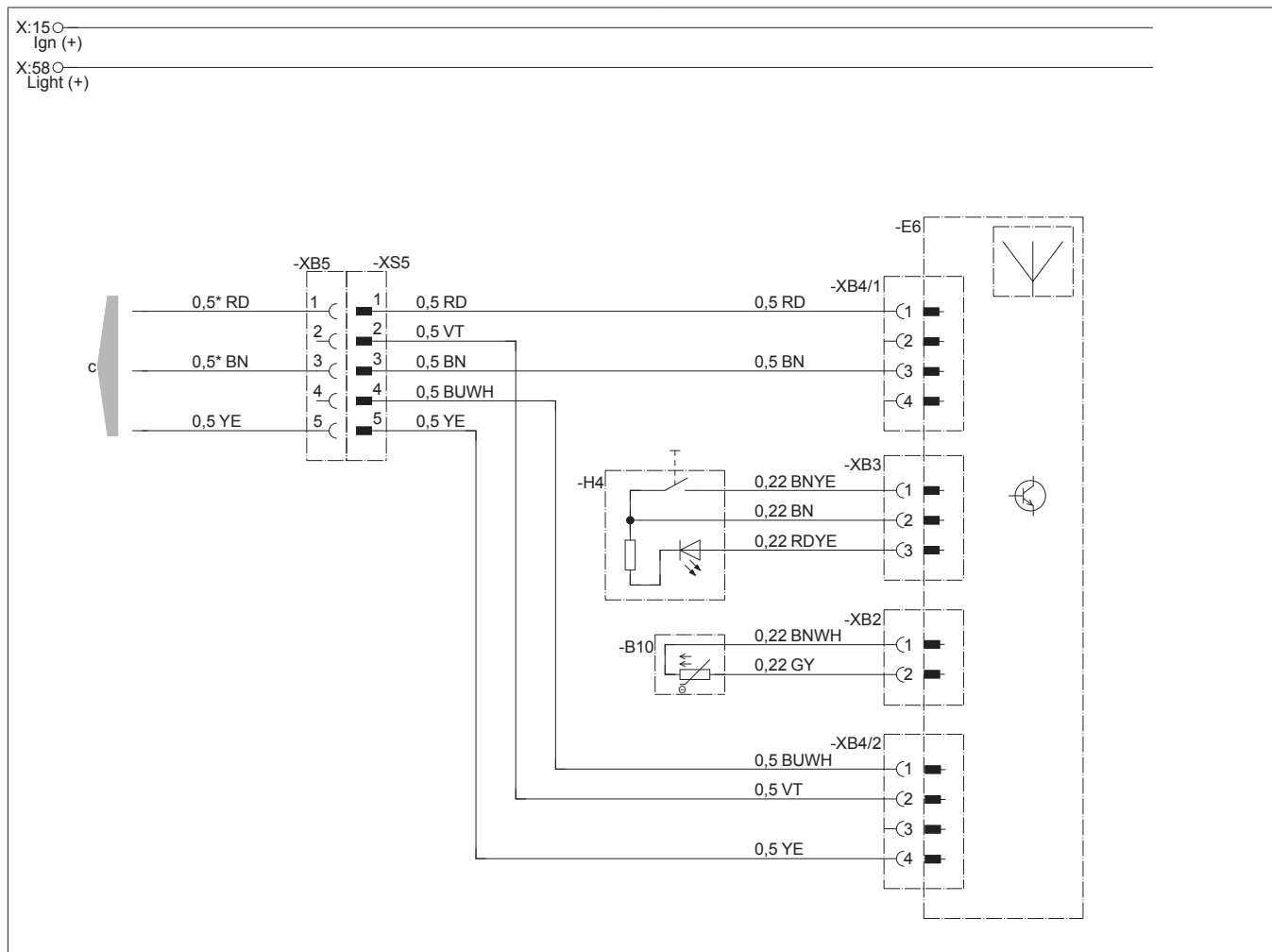

22.1000.34.9719.9A

Parts list

- B10 Easy Start Web interior temperature sensor
- E6 Easy Start Web radio remote control
- H4 Easy Start Web button
- c to the heater

Connectors and bush housings are shown from the cable inlet side.

Note

- With this connection constellation, fault diagnosis of the heater via the EasyStart Web control unit is not possible.
- Further circuit diagrams for the Easy Start Web are printed in the Installation Instructions Plus. They are available to view and download in the Service Portal.

Cable colours

RD	red	GR	grey	BK	black	WH	white	VT	violet
BU	blue	YE	yellow	GN	green	OR	orange	BN	brown

6 Troubleshooting / Maintenance / Service

6.1 Troubleshooting

If faults occur, check the following items first:

- If the heater does not start after being switched on:
 - Switch the heater off and on again.
- If the heater still does not start, check whether:
 - Fuel in the tank?
 - The fuses are ok?
 - The electrical cables, connections, terminals, are ok?
 - Is the combustion air system or exhaust system blocked?

Note

Always ensure that there is sufficient fuel in the tank, as the heater switches to fault and locks if operated without fuel.

If, after checking the items described above, the heater is still faulty or another malfunction occurs in the heater, please contact

- if factory-installed your contract workshop / garage.
- if subsequently installed, the workshop / garage that installed the heater.

Note

Please note that guarantee claims can expire if the heater is modified by a third party or if non-original parts are installed.

6.2 Maintenance instructions

Before the heating period starts, perform a trial run with the heater. If thick, persistent smoke develops, unusual burning noises or a clear fuel smell occurs or if electric / electronic components overheat, the heater must be switched off and put out of service by removing the fuse. In this case, the heater should not be started up again until it has been tested by qualified staff who have been trained on Eberspächer heaters.

Note

Check the openings of the combustion air supply and exhaust system after longer standstills, clean if necessary!

6.3 Service

Technical Support

If you have any technical questions or problems with the heater, the control unit or the operating software, please contact the following service address: support-UK@eberspaecher.com

7 Environment

7.1 Certification

The high quality of the Eberspächer products is the key to our success. To guarantee this quality, we have organised all work processes in the company along the lines of quality management (QM). Even so, we still pursue a large number of activities for continuous improvement of product quality in order to keep pace with the similarly constantly growing requirements made by our customers.

All the steps necessary for quality assurance are stipulated in international standards. This quality is to be considered in a total sense. It concerns products, processes and customer - supplier relationships. Officially approved public experts assess the system and the corresponding certification company awards a certificate.

Eberspächer has qualified for the following standards:

Quality management in accordance with
ISO TS 9001:2015 und IATF 16949:2016

Environmental management system in accordance with
ISO 14001:2015

7.2 Disposal

7.2.1 Disposal of materials

End-of-life devices, defect components and packaging material can all be separated and sorted into pure-grade factions so that all parts can be disposed of as required in an environment-friendly manner recycled where applicable.

Electric motors, control boxes and sensors (e.g. temperature sensors) are deemed to be “electrical and electronic scrap”.

7.2.2 Dismantling the heater

The heater is dismantled according to the repair stages in the current troubleshooting / repair instructions.

7.2.3 Packaging

The packaging of the heater can be kept in case the heater has to be sent back.

7.3 EU Declaration of Conformity

We herewith declare that the version of the heater placed on the market by us conforms to the applicable provisions of the following EC Directives.

EC Directive 2014/30/EU



The full Declaration of Conformity can be viewed and downloaded from the download centre at www.eberspaecher.com.



Eberspächer Climate Control
Systems GmbH & Co. KG
Eberspächerstraße 24
73730 Esslingen
Germany
info@eberspaecher.com
www.eberspaecher.com

