



Lil Ripppa
JACK

LIL RIPPPA 3.0 INSTRUCTIONS

SIDE WINDING JACK

BEFORE USING JACK, PLEASE READ THIS MANUAL TO PREVENT DAMAGE TO PROPERTY OR PERSONAL INJURY

WORKING LOAD LIMIT: 2000KG
COMPLIES WITH AS/NZ STANDARDS: 2693:2007

IMPORTANT: IMPROPER USAGE COULD CAUSE SERIOUS INJURY OR DAMAGE. PLEASE FOLLOW THE INSTRUCTIONS AS DIRECTED.

LUBRICATION REQUIREMENTS AND MAINTENANCE

Apply a small amount of automotive grease to all moving components every six (6) months via the grease nipple.

If used regularly, we advise you to lubricate more frequently.

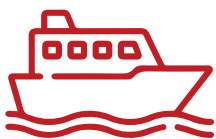
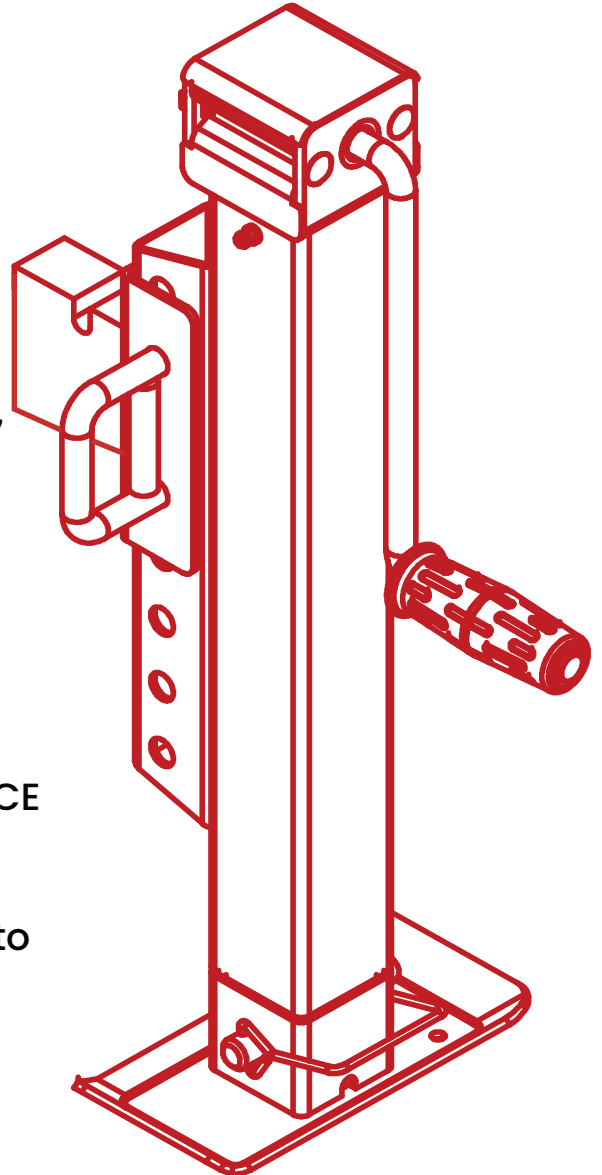

BOAT



CARAVAN



JETSKI

ASSEMBLY INSTRUCTIONS

ATTACH FOOT BEFORE USING

- Remove the jack and the foot from the box.
- Look for the pin at the base of the jack, opposite end to the handle.
- Remove the pin, insert the foot perpendicular to the handle.
- Slide the pin in and fasten the locking clip
- Place the foot on the ground, it should run parallel to the vehicle.

CONTENT OF BOX

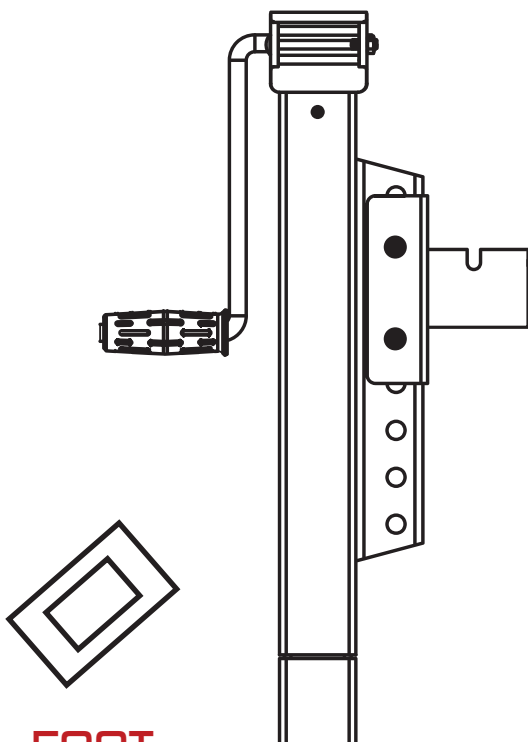

FOOT

JACK

AFTER FOOT INSTALLATION

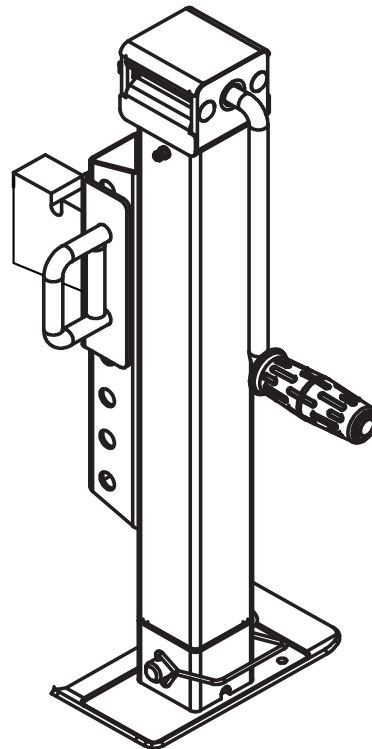

place the foot on the jack perpendicular to the handle and insert the pin as shown

OPERATING INSTRUCTIONS

1. Please make sure that no one is inside or on the trailer nor is anyone or any body parts under the trailer before, or during jacking operation.
2. Make sure that the caravan or trailer is on a level surface with firm and stable substrate wherever possible.
3. It is important that the trailer is also connected to the towing vehicle.
4. Apply the handbrake on the trailer and the tow vehicle. It is recommended to apply wheel chocks to the trailer and that no person should remain in the caravan or trailer that is being jacked.
5. No person should place any part of their body under the caravan or trailer that is being jacked.
6. Raise the trailer by winding the Lil Rippa Jack handle in a clockwise direction.
7. Ensure that wheel nuts of the wheel you are taking off are cracked BEFORE the wheel loses contact with the ground.
8. Change the wheel while fully raised
9. To lower, wind the Lil Rippa Jack handle counter clockwise.

SERVICING THE LIL RIPPA JACK

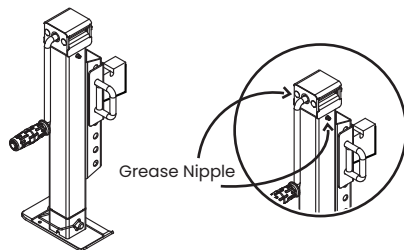

FOOT DIRECTION

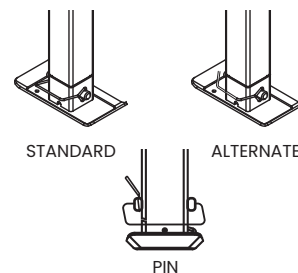

LOW APPLICATION

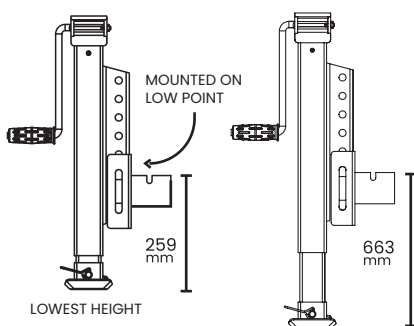

HIGH APPLICATION

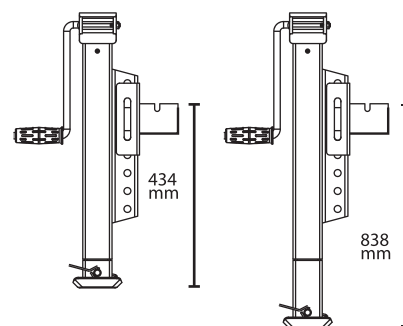

WARRANTY

1. This product is to be free from defects in material or workmanship at the time of purchase. If the product is found to be defective, the product may be replaced at the manufacturers discretion when the product is returned with proof of purchase.
2. Alterations, miss-use or improper installation of this product will void the warranty. The manufacturer's liability is limited to repair or replacement if found to be defective and specifically excludes liability for incidental or consequential loss or damage.
3. For more information contact: support@selecttrading.com.au