

# MAXWATT®

POWER WHEN YOU NEED IT

---

## INVERTER GENERATOR OPERATOR'S MANUAL





## **WARNING**

This product can expose you to chemicals including arsenic and lead which has been associated with birth defects and can be hazardous to our health.

## **DANGER**

Using a generator indoors **WILL KILL YOU IN MINUTES**. Exhaust contains carbon monoxide, a poison gas you cannot see or smell.

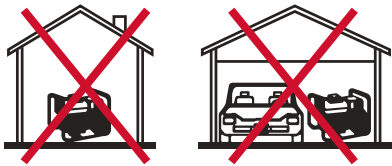

**NEVER** use in the home or in partly enclosed areas such as garages.



Only use **OUTSIDE** and far from open windows, doors, and vents.

Avoid other generator hazards.  
**READ MANUAL BEFORE USE.**

# TABLE OF CONTENTS

---

About Your Generator.....	1
Safety Information.....	13
Generator Safety Warnings.....	17
Know Your Generator.....	18
Generator Preparation.....	23
Starting the Generator.....	27
Shutting Off the Generator.....	29
Maintenance.....	30
Transportation & Storage.....	36
Troubleshooting Guide.....	37
Exploded View & Parts List.....	39
Warranty Conditions .....	42



## **ABOUT YOUR GENERATOR**

Thank you for purchasing a MAXWATT generator (hereinafter referred to as “the generator”).

This generator is suitable for use on various trade worksites, recreational such as camping and for use as backup power whether residential or commercial.

With built-in Pure Sine Wave technology (THD<5%), its perfect for powering tools, domestic appliances as well as sensitive electronics.

Please read and understand this manual for instructions on start-up, shut down, operations, adjustments, maintenance as well as safety guidelines before using this product. Please take all possible precautions to protect your own safety and that of the people in the immediate vicinity. This manual is the latest version. Save this manual for future reference.

As this product is continuously improved and upgraded, the manufacturer reserves the right to modify this manual without notice. The manufacturer shall not assume any liability for incorrect information contained in this manual.

This manual is an essential and important tool for the use of the generator. When the generator is transferred to new owners, the manual must be given to the new owners as well.





Some important information in this manual will be indicated in the following way. The owner/ user must pay special attention to these instructions.

MAXWATT is constantly improving its products. All information supplied in this manual is based on the latest product information available at the time of printing. The specifications outlined herein are subject to change without notice or obligation. The purchaser and/or user shall assume liability for any modification and/or alterations of this equipment from original design or manufacture.

## SPECIFICATIONS

<b>Model NO.</b>	<b>MX4500is</b>
<b>Starting Wattage</b>	<b>4500W</b>
<b>Running Wattage</b>	<b>3700W</b>
<b>Phase</b>	<b>Single</b>
<b>Frequency</b>	<b>50Hz</b>
<b>Voltage</b>	<b>AC 240V</b>
<b>Amperage</b>	<b>15.4A</b>
<b>Engine Type</b>	<b>4-stroke, OHV, single cylinder with forced air-cooling system</b>
<b>Engine Displacement</b>	<b>223cc</b>
<b>Fuel Tank Capacity</b>	<b>10.0 L, 87 octanes minimum</b>
<b>Oil Capacity</b>	<b>0.6 L</b>

## HAZARD SIGNAL WORD DEFINITIONS

	Indicates an imminently hazardous situation which, if not avoided, will result in death or serious injury. Obey all safety messages that follow this symbol to avoid possible injury or death.
 <b>DANGER</b>	Indicates an imminently hazardous situation which, if not avoided, will result in death or serious injury.
 <b>WARNING</b>	Indicates a potentially hazardous situation which, if not avoided, could result in death or serious injury.
 <b>CAUTION</b>	Indicates a potentially hazardous situation which, if not avoided, may result in minor or moderate injury.
<b>CAUTION</b>	Used without the safety alert symbol indicates a potentially hazardous situation which, if not avoided, may result in property damage.

For any queries on the above, please contact Maxwatt Power Products, the official service agent for all MAXWATT generators and water pumps.

The range of MAXWATT generators is safe and reliable, but incorrect usage of these products may cause personal injury and damage to the machine.

In order to operate the generator safely, strictly adhere to the operator's manual and please read it through carefully and thoroughly before using the generator.

### BEFORE STARTING

#### UNPACKING AND DELIVERY INSPECTION

You should inspect the generator immediately after you receive delivery thereof. If you have any missing parts, please contact your place of purchase. DO NOT attempt to operate the generator if there are any missing parts.

The generator is shipped without oil. You must add an adequate amount of engine oil before using it for the first time. The engine will be damaged beyond repair if it is started without oil. For oil type, please see "Recommended Oil Type" section of this manual on page 9. Fresh regular RON 91 fuel must be used in this unit. DO NOT use Premium or Ethanol based fuels.

#### SAFETY SIGNS

Comply with the instructions provided by the safety signs and symbols fitted to the generator and in this manual. The generator and manual only feature the symbols relevant to the model purchased. Check that the symbols and signs affixed to the unit are always present and legible, otherwise fit replacements in the original positions.

#### GENERAL WARNINGS & DISCLAIMER

READ and UNDERSTAND this manual completely before using the engine. Failure to properly set up, operate and maintain this engine could result in serious injury or death from carbon monoxide poisoning, electric shock, fire/explosions and/or burns.

In particular be aware of the following hazards:

## **CO Poisoning**

Engines give off carbon monoxide, an odourless, colourless poisonous gas that can kill you. You CANNOT smell it, see it or taste it. ONLY run an engine OUTDOORS and AWAY from building air intakes NEVER run an engine inside any enclosed or semi-enclosed spaces, including homes, basements, garages, sheds, boxes, RV's, boats or pick-up truck beds. These spaces can trap poisonous gases, EVEN if you run a fan or open windows.

## **Electric Shock / Electrocutation**

High voltage electricity from the generator can kill. DO NOT operate in wet locations or conditions. Be sure the generator is properly grounded. Use only outdoor rated grounded extension cords of proper size.

NEVER plug the generator directly into a wall plug outlet. ANY connection to a building's electrical system MUST ISOLATE THE GENERATOR FROM UTILITY POWER via a transfer switch installed by a licensed electrician.

Otherwise, back-feed from the generator into the power grid could kill utility workers. See "Set up as a building back-up" on page 13 for additional information.

BEFORE performing any maintenance on the generator, disconnect the engine starting battery (if equipped) to prevent accidental start-up. Disconnect the cable from the battery post indicated by a NEGATIVE, NEG or (-) first. Reconnect the cable last.

## **Heat**

Unintentional spark can result in fire and/or electric shock.

## **Fire / Explosion**

DO NOT overload the engine (per rate capacity) and OPERATE ONLY in an area with adequate cooling ventilation so the engine does not overheat. The exhaust can be extremely hot. Keep the muffler at least 3 metres from all combustible objects.

All fuels are flammable. Never fuel a running or hot engine. Never pump fuel directly into the engine at a petrol station – use an approved container to transfer the fuel. Ensure that there are no fuel leaks and keep sources of sparks and flames away. Wait for the engine to be cool before fuelling. ALWAYS keep a fire extinguisher rated "ABC" nearby.

## **STOP!**

CHOOSE THE RIGHT GENERATOR FOR YOUR NEEDS. See the Power Load Planning and Management section to determine your power load requirements and then compare to the generator's rate capacity.

## **INSPECT COMPONENTS**

Closely inspect to make sure that there are not any components missing or damaged.

ARRANGE FOR PROFESSIONAL INSTALLATION of a transfer switch if you will be connecting the generator to your building's system.

## **GENERAL SAFETY RULES FOR OPERATION**

**Save all warnings and instructions for future reference.**

This equipment is to be used for the purpose for which it is designed and intended.

Seek assistance if required when moving or lifting the generator.



**WARNING !**

**HAZARDOUS KEEP NEW AND USED BATTERIES OUT OF REACH OF CHILDREN.**

Never allow children to replace button batteries on any device. Swallowing or placing inside any part of the body may lead to severe or fatal injuries in as little as 2 hours or less due to chemical burns and potential perforation of the oesophagus.

**If you suspect your child has swallowed a button battery or placed inside any part of the body, immediately call the POISONS INFORMATION CENTRE on 13 11 26 for prompt advice. If your child is having any difficulty breathing, contact 000.** Dispose of used button/ coin batteries immediately and safely. A battery can still be dangerous even when it can no longer operate the device. Place sticky tape around both sides of the battery and dispose of it immediately out of reach of children in an outside bin or recycle safely.

**WORK AREA SAFETY**

Intended for outdoor use only.

1. DO NOT operate in confined spaces or indoors as carbon monoxide released from the exhaust can kill.
2. DO NOT operate in explosive atmospheres such as in the presence of flammable liquids, gases or dust.
3. Keep children and bystanders away while operating a generator. Distractions can cause you to lose control.
4. Keep your work area clean and well lit. Cluttered benches and dark areas invite accidents.
5. This generator is not weatherproof. Exposure to rain, damp conditions or extreme temperatures can cause damage or serious injury.

**PERSONAL SAFETY**

1. Stay alert, watch what you are doing and use common sense when operating a generator.
2. DO NOT use a generator while you are tired or under the influence of drugs, alcohol or medication. A moment of inattention may result in serious personal injury.
3. Use personal protection equipment. Always wear eye protection. Wear approved safety impact eye goggles, dust mask, non-skid safety shoes, hard hat and hearing protection for appropriate conditions.
4. DO NOT overreach. Keep proper footing and balance at all times. This enables better control of the generator in unexpected situations.
5. Dress properly. DO NOT wear loose clothing, gloves, neckties or jewellery. Keep your hair and clothing away from moving parts. Loose clothes, jewellery or long hair can be caught in moving parts.
6. DO NOT let familiarity gained from frequent use of the generator allow you to become complacent and ignore safety principles and rules. A careless action can cause severe injury within a fraction of a second.
7. For your own safety, do not operate your generator until it is completely assembled and installed according to the instructions and until you have read and understood all of the instructions.

**GENERATOR SAFETY RULES**

1. DO NOT force the generator. Use the correct generator for your application. The correct generator will do the job better and safer at the rate for which it was designed.
2. DO NOT use the generator if the engine switch does not turn it on and off. Any generator that cannot be controlled with the switch is dangerous and must be repaired.

3. Know how to stop the generator without hesitation. Be thoroughly familiar with proper use of the equipment and all engine controls, output receptacles and connections. Know how to stop the engine quickly (see "Stopping the Generator").
4. The engine owner must instruct all operators in safe engine set-up and operation. Only trained adults should set up and operate the engine. DO NOT let children operate it.
5. Carefully read about and understand the intended use of this engine. DO NOT use for other purposes as unforeseen hazards or equipment damage may result. NEVER operate or let anyone else operate the engine while under the influence of alcohol, drugs or medication.
6. DO NOT operate the engine unless all safety covers, guards and barriers are in place and in good working order – and that all controls are properly adjusted for safe operation.
7. DO NOT operate the generator with damaged, missing or broken parts.
8. DO NOT modify the generator in any way. Modifications can create hazards and will also void the warranty.
9. NEVER attempt to modify the generator speed setting. The generator speed is present for safe and optimal performance of the generator. If speed needs adjusting, it must be done by factory personnel.
10. NEVER attempt to connect external fuel sources in order to increase generator run time. A large tank at pressure or higher elevation will cause a leak from the carburettor during operation. A fire or an explosion could result.
11. Always turn off the generator and remove the spark plug(s) or spark plug wire(s) before working on the generator to prevent accidental starting. Always discharge the capacitor before working on the generator head to prevent electrical shock. (See Maintenance & Repair section of this manual for instructions on how to do this.)
12. The running generator gives off carbon monoxide, a poisonous gas that can kill you. You CANNOT smell it, see it, or taste it. Follow all instructions for site selection and positioning of the generator and avoid inhaling the exhaust. If you start to feel sick, dizzy or weak while using the generator, shut off the generator and get to fresh air RIGHT AWAY. See a doctor. You may have carbon monoxide poisoning.

**Immediately turn off the generator if any of the following conditions arise during operation:**

1. Excessive change in generator speed, slow or fast;
2. Sparking or arcs from generator;
3. Loss of electrical output;
4. Receptacle damage;
5. Generator misfire;
6. Excessive vibration;
7. Flame or smoke or
8. Abnormal noise

This product contains or emits chemical known to the Commonwealth of Australia to cause cancer, birth defects or other reproductive harm. Avoid inhalation of exhaust.

DO NOT operate the engine or handle any electrical equipment while standing in water, while barefoot, while hands are wet or while in the rain or snow. An electric shock may result.

Avoid contact with bare wires, terminals, connections, etc. while the generator is running.

If an electric shock accident occurs, immediately shut down the source of electrical power. If this is not possible, attempt to free the victim from the live conductor. Avoid direct contact with the victim. Use a non-conducting implement, such as a dry rope or board, to free the victim from the live conductor. Administer/apply applicable first aid and get immediate medical help.

Never smoke near the running engine and never operate near sources of sparks or flames.



## **SERVICE**

Have your generator serviced by a qualified repair person using only factory approved replacement parts. This will ensure that the safety of the generator is maintained. Incorrectly fitted parts will void your warranty.

The equipment may only be used, maintained or repaired by those persons who understand and have been instructed about the potential dangers. Independent changes in the equipment cancel any manufacturer's liability for any damages that result from these changes.

## **APPROPRIATE USE**

Use the equipment only when it is in technically perfect condition and only for appropriate jobs, with an awareness of safety and possible dangers, based on observation of the operating instructions. In particular, problems which could influence the operational safety must be dealt with immediately.

All of the manufacture's safety, work and maintenance regulations as well as the given norms in the Technical Data must be observed.

## **STATIC ELECTRICITY AND FILLING THE PETROL TANK**

Static electricity can initiate from un-grounded petrol tanks or containers from flowing petrol and persons carrying a static electric charge. Static electricity can explosively ignite petrol vapours that are present during the fuelling process, resulting in serious burns to nearby persons.

Many objects can accumulate and retain a static electric charge. Objects made of non-conductive materials (eg. plastics) easily accumulate and retain static electrical charge, as can objects made of conductive material (eg. metal, water) if they are not electrically grounded.

To avoid static electricity while fuelling, certain steps must be followed before and during the fuelling process in order to minimise and safely dissipate static charge build-up:

Touch a grounded metal object before starting. Always dissipate static charge from your body before beginning the fuelling process by touching a grounded metal object at a safe distance away from the fuel source.

Use a portable container to fill the tank. NEVER fill the engine's petrol tank directly from the fuel pump – the engine's tank is not grounded and the high velocity flow of petrol from a fuel pump can cause static electric build-up. Use an approved portable container to transfer to the engine's tank.

## **TYPICAL SOURCES OF STATIC ELECTRIC HAZARDS DURING FUELLING**

The following objects can accumulate a static electric charge and cause an ignition spark in typical fuelling situations:

### **1. Ungrounded tanks/containers.**

Any ungrounded fuel tank or container can accumulate a static electric charge as a result of contact with other objects or friction during transportation. This static electricity can discharge as a spark to the grounded petrol dispenser nozzle as the nozzle is first brought close to the tank/container at the beginning of the fuelling process.

### **2. Flowing petrol.**

People are not aware that petrol accumulates static electric charge while flowing through a hose or pipe. This charge then transfers to and accumulates in the gas tank or container that is being filled. The total amount of charge accumulation depends on the amount of gas pumped into the container, the speed with which it is pumped, and whether or not the tank/ container is grounded. If sufficient static electric charge accumulates in the fuel tank or container during the

fuelling process, the tank/container may discharge a spark to the grounded petrol dispenser nozzle.

The person dispensing the petrol can carry a static electric charge on their body, typically resulting from contact with their car seat or electronics. The static electricity can discharge a spark between that person's hand and either the grounded dispenser nozzle or the fuel tank opening.

## GENERATOR SET UP

### PLANNING THE POWER LOAD

Plan your power load so that you do not exceed the generator's rate capacity. To calculate the running and start wattage requirements for the devices you will be powering, follow the steps on page 18.

### SET UP THE PORTABLE POWER SOURCE

This generator is designed to provide up to its maximum power (in watts) of electrical power. When using the generator as a portable power source, you can plug electric devices and appliances directly into the generator's electrical outlets. This generator is equipped with two SAA approved IP66 rate socket outlets.

Make sure you plug each electrical device/appliance into the correct generator outlet based on the device's plug configuration and voltage/amperage rating. NEVER exceed the amperage rating of an outlet.

**Note:** You must NOT overload the generator. Overloading may cause serious damage to the generator and attached electrical devices.

### SET UP AS BUILDING BACK UP

To set up as a building backup, you must arrange for a licensed electrician to connect the generator to your building's electrical system via the installation of an approved transfer switch. The transfer switch must be installed in accordance with the building's electrical code and guidelines supplied by the power company.

A transfer switch does the following:

- A Safely connects the generator to your building's electrical system by isolating your generator from your utility company's power lines.
- B Connects your generator to a critical subset of your building's circuits that are needed for emergency power needs.

 <b>DANGER</b>	<p>A transfer switch must be installed in order to isolate your generator from the utility power grid. If your generator is NOT properly isolated from the utility system, serious hazards will arise.</p> <p>When your generator is running, its output will back feed into the utility power line and transformer that are normally used to provide you with power. The transformer will step up the current to the normal line voltage. An unsuspecting utility line worker working on what he thinks is a deactivated line could be electrocuted.</p> <p>If your generator is connected (running or not) when utility power is restored, your generator will be destroyed. It could also explode or cause fire.</p>
---	---



**Note:**

Regardless of whether you use your generator as a back-up power source connected to a building or as a portable power source, you **MUST NOT** overload the generator. Overloading may cause serious damage to the generator and attached electrical devices.

If your generator will be connected to your building’s system, it **MUST ALWAYS BE** isolated from the utility power grid with an approved transfer switch installed by a licensed electrician, in compliance with all applicable building and electrical codes and in accordance with the guidelines supplied by the power company.

There may be Federal or State Occupational Safety and Health Administration (OSHA) regulations, local codes or ordinances that apply to the intended use of the generator.

Please consult a qualified electrician, electrical inspection or the local agency having jurisdiction.

In some areas, generators are required to be registered with local utility companies.

If the generator is used at a construction site, there may be additional requirements that must be observed.

**GROUNDING THE GENERATOR**

 <b>WARNING</b>	<p>In order to avoid electrical accidents, all connections to the distribution panel must be carried out by qualified technicians. Incorrect connections can harm people and damage the generator.</p> <p>Operating the generator when it’s not properly grounded can result in electrical shock.</p>
--	---

1. Standard generators are protected by electrical separators. This equipment has a thermic protection device and/or magnet-to-thermic device to protect against a surge of current, overloading and short-circuiting. In these cases, the generator should under **NO** circumstances, be earthed using the terminal “PE” or with any other part of the generator.
2. If a licenced electrician installs the generator with a connection to your building’s electrical circuit for use as a back-up power system, grounding may alternatively be completed through the building’s grounding system. Ask your electrician.

 <b>WARNING</b>	<p>Grounding is not required when the generator is used as a portable power source. Below grounding method is only needed by a qualified electrician if not connecting through your building’s electrical system.</p>
--	---

3. If the generator is not grounded through your building’s system, follow the procedure below. This procedure can only be carried out by a licensed electrician.
4. Drive a ¾” or 1” copper pipe or rod into the ground close to the generator. The pipe/rod must penetrate moist earth – the depth required will be dictated by local soil conditions.
5. Connect an approved ground clamp to the pipe.
6. Run a 10-gauge wire from the clamp to the generator grounding post located on the rear of the generator head.

- Do not connect the generator grounding post to a water pipe or a ground used by the radio system.

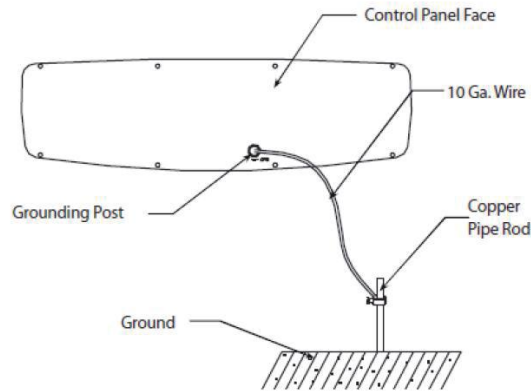

### EXTENSION CORDS

Extension cords may be used to power devices that are located at a distance from the generator. However, use only Australian approved outdoor-rated, grounded extension cords. Locate the generator in a convenient place and where possible, avoid long extension leads and possible damage to leads by pedestrian or vehicular traffic.

Extension leads should be heavy duty with at least 1mm of appropriate current rating and in any case, not less than 1mm cross-section of conductor and must incorporate an earthing conductor to ensure that there is not any voltage difference between the generator set and any equipment powered by the generator.

The electrical continuity of the “earthing” core should be checked periodically from pin to socket to ensure continued electrical safety. Some electrical appliances, eg. portable drills, are marked “double insulated”, in which case there should not be an earthing conductor in its mains lead (even though it may have a three-pin plug).

 <b>WARNING</b>	<p>Use of under sized extension cords can cause electric shock, fire, or damage to connected devices. All extension and appliance cords must be in good condition and not worn, bare, frayed, or otherwise damaged.</p> <p>Use of damaged electric cords can cause electric shock or fire. Note: If an extension cord becomes hot to the touch, it is overloaded or damaged and must be replaced. SABER is NOT responsible for damage or injury resulting from customer use of inadequate extension cords.</p>
--	--

### SELECT A SUITABLE SITE

Before using the generator, you must select a suitable OUTDOOR location for installation and operation that meets the following criteria:

#### DRY, LEVEL SURFACE

The generator should be positioned on a dry, firm and level surface. Ensure that the generator sits level and will not slide or shift during operation. If applicable, block the generator’s wheels to prevent sliding and shifting.

 <b>WARNING</b>	<p>You must choose a suitable site for operating your generator to avoid equipment damage and/or injury and possible death from carbon monoxide poisoning, electric shock, or fire.</p>
--	---

## OUTDOORS ONLY

Follow the directions below for choosing a location to operate your generator in order to avoid carbon monoxide poisoning:

1. The location you choose to operate the generator must be **OUTDOORS** and away from all building air intakes.
2. Never run the generator inside any closed or semi-enclosed spaces (even if outdoors), including homes, garages, basements, sheds or boxes. These spaces can trap poisonous gases, even if you run a fan or open windows.
3. Ensure that working, battery-operated or battery back-up carbon monoxide alarms are used in any dwelling/structure that is in close proximity to the running operator.

### **Note:**

This generator is **NOT** designed or approved for use in vehicles or marine applications. Never run the generator inside RVs or other vehicles such as boats or on pick-up truck beds.

 <b>WARNING</b>	<p>The exhaust from your generator contains carbon monoxide (CO), a poisonous gas that can kill. You cannot smell it, see it, or taste it. Breathing carbon monoxide can cause loss of consciousness and may lead to death. Never run your generator in a conned or even partially enclosed areas or near open windows or doors.</p> <p>Never attempt to attach ductwork to the muffler system to allow for installation inside an enclosure. This could cause hot air, heat build-up and increased exhaust back-pressure, resulting in possible exhaust leakage or damage to the generator.</p>
--	--

## **ADEQUATE COOLING VENTILATION**

The generator needs adequate, unobstructed flow of air to allow for proper cooling of the engine and generator head.

1. Never place the generator immediately adjacent to a building or other structure – allow at least 2 metres clearance.
2. Do not run the generator in close proximity to other heat-generating equipment, such as another generator. The combined heat that is generated may raise air temperature in the immediate area and there will not be adequate cooling ventilation.
3. Do not allow debris to accumulate and block airflow.
4. Do not operate with a tarp, blanket, or cover surrounding the generator.

 <b>WARNING</b>	<p>Heat build-up from inadequate ventilation can result in fire, posing a serious risk to nearby persons and structures. Situate so there is adequate clearance around generator to allow for cooling airflow so that heat does not build up.</p>
--	---

## **HOT EXHAUST CLEARANCE**

Make sure your generator's exhaust system is at least 2 meters from all combustible materials and buildings/structures.

Equip the engine with a spark arrestor if the generator will be used near any ignitable forest, bush, brush, or grassy land. (see the "Specifications" section of this manual to determine if your generator is already equipped). Make sure you comply with applicable local, state and federal codes.

Keep a fire extinguisher rated "ABC" nearby. Keep it properly charged and be familiar with its use.

## NO WET CONDITIONS

Choose a location where the generator will NOT be exposed to rain, snow or direct sunlight. Exposure to water can cause an electric shock. You may operate the generator under an outdoor canopy-like structure of heat-resistant material that is open on all sides.

Make sure that all parts of the canopy are at least 2m from the exhaust and allow for adequate clearance above the generator so that heat does not build up.

## OPERATE AWAY FROM DUST/DIRT

Do not use the generator in extremely dusty or dirty conditions. Excessive dust and dirt can cause premature failure of the machine.

## HEARING PROTECTION

Generators can produce noise levels >70dB in close proximity, which can be dangerous to human hearing with prolonged exposure to the running generator for an extended period of time.

## An Important Message about Temperatures

 <b>WARNING</b>	Never attempt to attach ductwork to the muffler system to lower noise levels. This could cause hot air deflection, heat build-up and increased exhaust back-pressure, resulting in possible exhaust leakage or damage to the generator.
--	---

Your generator is designed and rated for continuous operation at ambient temperatures up to 40 degrees Celsius. When your generator is needed, it may be operated at temperatures ranging from -15 degrees Celsius to 50 degrees Celsius for short periods.

If the generator is exposed to temperatures outside this range during storage, it should be brought back within this range before operation. In any event, the generator must always be operated outdoors, in a well-ventilated area and away from doors, windows and other vents.

When operated above 25 degrees Celsius, there may be a decrease in power.

Maximum wattage and current are subject to and limited by such factors as fuel BTU content, ambient temperatures, altitude, engine condition etc. Maximum power decreases about 3.5% for each 1000 feet above sea level, and will also decrease about 1% for each -12.2 degrees Celsius above 16 degrees Celsius ambient temperature.

## SAFETY INFORMATION

 <b>WARNING:</b> Before operating the generator, make sure to read all safety warnings and all instructions. Failure to follow the warnings and instructions may result in electric shock, fire or serious injury.
---

## SAFETY INTRODUCTION

Safety is a combination of common sense, staying alert, and knowing how your tool works. This manual contains important information regarding the generator's potential safety concerns, as well as preparation, operation, and maintenance instructions. Before operating this generator, be sure to read and observe all warnings and instructions both on the generator labels and in this instruction manual. Failure to follow all instructions listed below may result in personal injury.



**NOTE:**

The following safety information is not meant to cover all possible conditions and situations that may occur. We reserve the right to change this product and specifications at any time without prior notice.

**SAVE THESE INSTRUCTIONS** - Please keep this manual available to all users during the entire life of the tool. Review it frequently to maximize safety for both yourself and others.

**SAFETY SYMBOLS**

The purpose of following safety symbols is to attract your attention to possible dangers. The safety symbols, and their explanations, deserve your careful attention and understanding. The safety warnings do not by themselves eliminate any danger. The instructions or warnings they give are not substitutes for proper accident prevention measures.

-  **DANGER:** indicates a hazard, that, if not avoided, will result in death or serious injury.
-  **WARNING:** indicates a hazard, that, if not avoided, could result in death or serious injury.
-  **CAUTION:** indicates a hazard, that, if not avoided, might result in minor or moderate injury.

**CAUTION:** when used without the alert symbol, indicates a situation that could result in damage to the machine.

**NOTICE REGARDING EMISSIONS**

Engines that are certified to comply with U.S. EPA emission regulations for SORE (Small Off-Road Equipment), are certified to operate on regular unleaded gasoline, and may include the following emission control systems: (EM) Engine Modifications and (TWC) Three-Way Catalyst (if so equipped).



## GENERATOR SAFETY WARNINGS

### DANGER: CARBON MONOXIDE

Using a generator indoors **CAN KILL YOU IN MINUTES**. A generator exhaust contains carbon monoxide (CO). This is a poison gas you cannot see or smell. If you can smell the generator exhaust, you are breathing CO. But even if you cannot smell the exhaust, you could be breathing CO.



NEVER use a generator inside homes, garages, crawl spaces, or other partially enclosed areas. Deadly levels of carbon monoxide can build up in these areas. Using a fan or opening windows and doors does NOT supply enough fresh air. ONLY use a generator OUTSIDE and far away from windows, doors, and vents. These openings can pull in generator exhaust.

Even if you use a generator correctly, CO may leak into the home. ALWAYS use a battery-powered or battery-backup CO alarm in the home. If you start to feel sick, dizzy, or weak after the generator has been running, move to fresh air RIGHT AWAY. See a doctor. You may have carbon monoxide poisoning.

### WARNING: RISK OF EXPLOSION. HIGHLY FLAMMABLE:

This generator may emit highly flammable and explosive gasoline vapors, which can cause severe burns or even death, if ignited. A nearby open flame can lead to explosion even if not directly in contact with gasoline.

- Do not operate near open flame, heat, or any other ignition source. Do not smoke near the generator.
- Always operate the generator on a firm, level surface.
- Always turn the generator off before refueling. Allow the generator to cool for at least 2 minutes before removing the fuel cap. Loosen the cap slowly to relieve the pressure in the tank.
- Do not overfill the fuel tank. Gasoline may expand during operation. Do not fill to the top of the tank. Allow for expansion. Always check for spilled fuel before operating.
- If fuel spills, move the generator at least 30 feet away from the spill and wipe clean any spilled fuel before starting the engine.
- Empty the fuel tank before storing or transporting the generator.

### WARNING:

If this generator is used as a supply for a BUILDING'S WIRING SYSTEM, the generator MUST be installed by a qualified electrician and connected to a transfer switch as a separately derived system in accordance with all applicable laws and electrical codes and the National Electrical Code, NFPA 70. The generator shall be connected to a transfer switch that switches all conductors excluding the equipment grounding conductor. The frame of the generator shall be connected to an approved grounding electrode.

## GENERATOR SAFETY WARNINGS



### **WARNING:**

Do not let comfort or familiarity with the product replace strict adherence to product safety rules. Failure to follow the safety instructions may result in serious personal injury.

## OPERATING ENVIRONMENT

1. Using a generator indoors can kill you in minutes. Only use a generator OUTSIDE and far away from windows, doors and vents.
2. Do not smoke near the generator.
3. Do not operate near open flame, heat, or flammable materials. This generator may emit highly flammable and explosive gasoline vapors, that can cause severe burns or even death if ignited. A nearby open flame can lead to an explosion even if it isn't directly in contact with gasoline.
4. Do not expose the generator to rainy or wet conditions; doing so significantly increases the risk of electrical shock. Never handle the generator, electronic devices, or any cord while standing in water, while bare-foot, or when hands or feet are wet.
5. Always operate the generator on a dry, firm, level surface.
6. The generator should have at least 5 feet of clearance from buildings or other equipment during operation.
7. Do not allow children or non-qualified persons to operate the generator.

## GENERATOR PREPARATION

1. Always ground the generator before using it to maximize safety (see "GROUND THE GENERATOR" section).
2. Do not overfill fuel tank, as gasoline may expand during operation. Do not fill to the very top of the tank. Leave room for gasoline expansion. Always check for spilled fuel before operating.
3. If any part of the generator, electrical device or power cord is broken, damaged, or defective, make sure it is repaired or replaced before operation. Service should only be performed by a qualified technician. Do not use receptacles or cords that show signs of damage, such as broken or cracked insulation.
4. Use a ground fault circuit interrupter (GFCI) in highly conductive areas such as metal decking or steel work. Extension cords with in-line GFCIs are recommended for these operations to maximize safety.
5. If connecting the generator to a building's electrical system for standby power, you MUST consult a qualified electrician and install a transfer switch. Such connections must comply with local electrical laws and codes. Failure to comply can create a back-feed, which may result in serious injury or death to utility workers.
6. Never modify the generator in any way. Modifying or using the machine for any other purpose for which it is not designed may result in serious injuries, machine damage and voiding of the warranty

## GENERATOR SAFETY WARNINGS

### GENERATOR OPERATION

1. Only use the generator for its intended purposes. Modifying or using the generator for operations for which it was not designed may cause hazards and personal injury.
2. Do not touch bare wires or receptacles (outlets).
3. Do not exceed the wattage capacity of the generator by plugging in more electrical devices than the unit can handle. This could damage the generator and/or connected electrical devices. Check the operating voltage and frequency requirements of all electrical devices prior to plugging them into the generator.
4. Allow generator to run for several minutes before connecting electrical devices. Do not start or stop engine with electrical devices plugged into the receptacles. Failure to do so could damage the generator and / or connected electrical devices.
5. Do not turn ON electrical devices until after they are connected to the generator.
6. Generators vibrate in normal use. During and after the use of the generator, inspect both the generator as well as extension and power supply cords for damage resulting from vibration.
7. Do not touch HOT PARTS. This generator produces heat when running. Temperatures near exhaust can exceed 150° F (65° C). Allow generator to cool down after use before touching engine or areas of the generator that become hot during use.
8. Turn off all connected electrical devices before stopping the generator.
9. Always turn generator off before refueling. Allow generator to cool for at least 2 minutes before removing fuel cap. Loosen cap slowly to relieve pressure in tank.
10. Turn the engine switch to "OFF" position when the engine is not running.
11. Empty fuel tank before storing or transporting the generator. Do not store generator or gasoline near furnaces, water heaters, or any other appliances that produce heat or have automatic ignitions. Store the generator and fuel away from sparks, open flames, pilot lights, heat and other sources of ignition.
12. Always wash hands after handling generator.

**CAUTION:** Misuse of this generator can damage it or shorten its lifespan.

#### **TO MAXIMIZE THE LIFESPAN OF YOUR GENERATOR:**

We recommend running your generator at least once a month for 20 to 30 minutes. Start the generator according to the instructions and plug a small load in to make sure the outlet is producing electricity. If you do not run it often, it will greatly shorten the generator's lifespan and void the warranty.



# KNOW YOUR GENERATOR

## GENERATOR

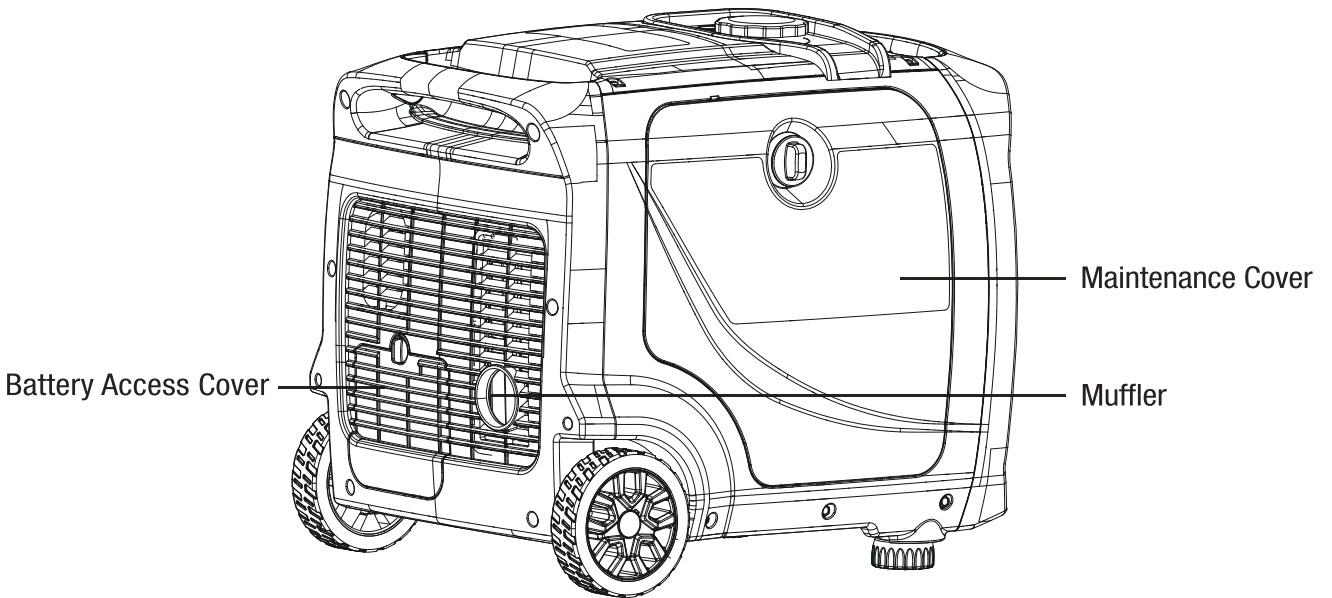
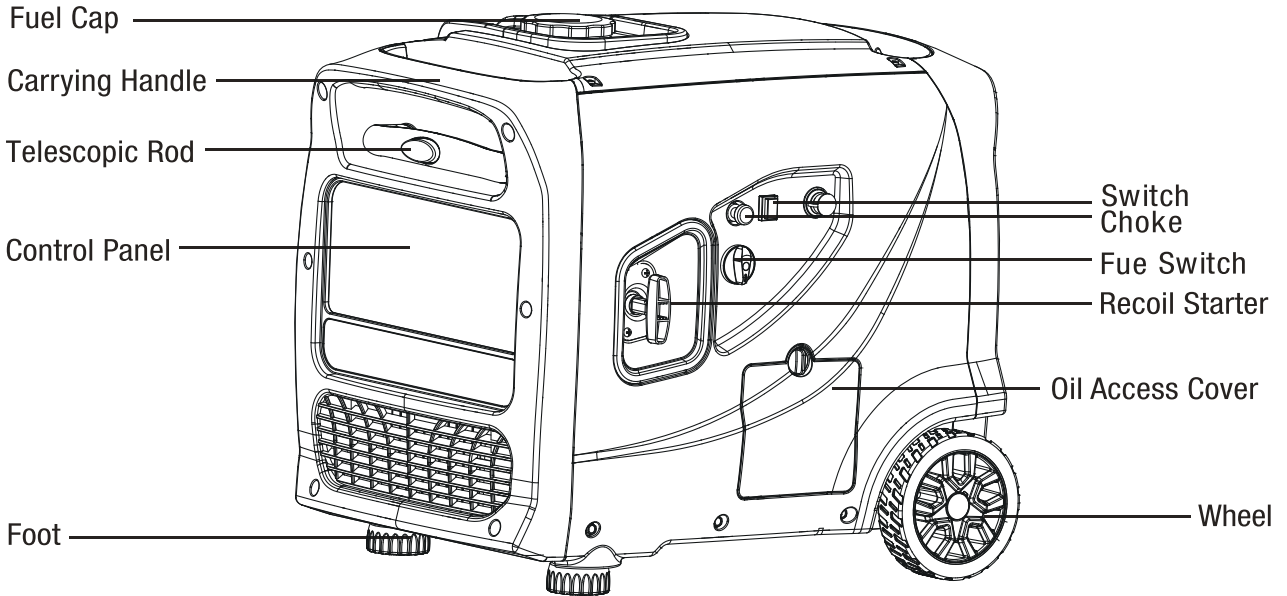

# CONTROL PANEL

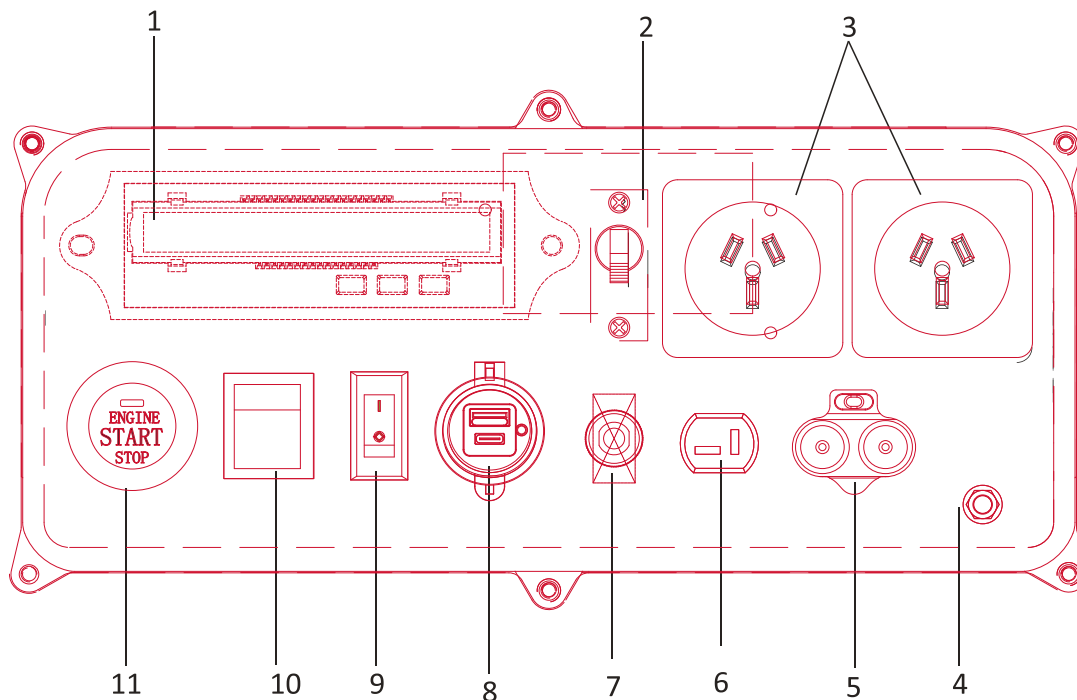

1. Data Center  
Voltage, Run Time, Frequency
2. MAIN BREAKER
3. AC Receptacles
4. Grounding Nut  
Ground generator to reduce risk of electric shock
5. Parallel Operation Outlets  
Connect two inverter generators through a parallel connection kit for a higher output
6. DC 12V
7. DC CIRCUIT BREAKER
8. DC 5V USB Outlets
9. 10.Low Idle  
Turn ON to increase fuel economy and runtime when the load is below 75% load
10. Main Switch
11. Engine START/STOP switch

## PARALLEL OPERATION

The parallel operation outlets (Fig. 2) allow you to connect two generators to increase the total available electrical power. The load plugs can now be plugged into the AC sockets. Ensure that the load is split between the 2 sockets, **DO NOT OVERLOAD THE SOCKET WITH MORE THAN 15 AMPS OR 3600 Watts.**

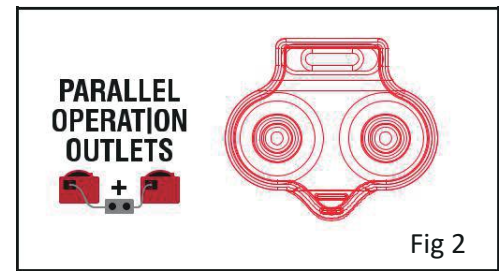

Fig 2

## CIRCUIT BREAKERS

The circuit breakers (Fig. 3) protect the individual AC and DC circuits. The AC circuit breaker will activate when the AC outlets exceed. The DC circuit breaker will activate when the DC 12V and USB outlets exceed. When the circuit breaker activates, turn off and disconnect the device from its respective outlet, and press the circuit breaker to reset.

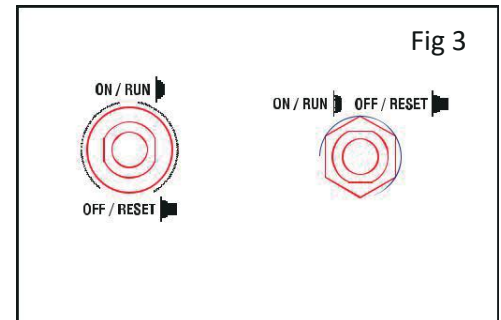

Fig 3

## CONNECTING ELECTRICAL DEVICES

### CAUTION:

Before connecting devices, become familiar with the markings on the control panel before connecting electrical devices.

### Follow the steps below to properly connect your device(s) to the generator:

1. Before connecting electrical devices, allow the generator to run for a few minutes to stabilize the speed and voltage output.
2. Select the device with the highest wattage, and make sure it is turned off. Plug the device into the generator and then turn the device on. Allow the engine to stabilize.
3. Repeat step 2 to plug in each additional device. **DO NOT** attempt to plug in or start multiple devices at the same time.

## GENERATOR CAPACITY

Make sure the generator can supply enough running (rated) and starting (max.) watts for the items you will power at the same time. Follow these simple steps.

1. Select the items you will power at the same time.
2. Total the running (rated) watts of these items. This is the amount of power the generator must produce to keep the items running.
3. Estimate how many starting (max.) watts you will need. Starting wattage is the short burst of power needed to start electric motor-driven tools or appliances such as a circular saw or refrigerator. Because not all motors start at the same time, total starting (max.) watts can be estimated by adding only the item(s) with the highest additional starting (max.) to the total rated watts.

## Example:

Tool or Appliance	Running Watts*	Additional Starting Watts*
Refrigerator	700	1350
Portable Fan	40	120
Laptop	250	250
46 in. Flat Panel Television	190	190
Light (75 Watts)	75	75
	1255 Total Running Watts	1350 Highest Starting Watts

TOTAL RUNNING WATTS: 1255  
HIGHEST STARTING WATTS: +1350  
TOTAL STARTING WATTS NEEDED: 2605

To prolong the life of the generator and attached devices, it is important to take care when adding electrical loads to the generator. There should be nothing connected to the generator outlets before starting its engine.

The correct and safe way to manage generator power is to sequentially add loads as follows:

1. With nothing connected to the generator, start the engine as described later in this manual.
2. Plug in and turn on the first load, preferably the largest load you have.
3. Permit the generator output to stabilize (engine runs smoothly and attached device operates properly).
4. Plug in and turn on the next load.
5. Again, permit the generator to stabilize.
6. Repeat steps 4 and 5 for each additional load.

Never add more loads than the generator capacity. Take special care to consider surge loads in generator capacity as previously described.

**NOTICE:**

Do not overload the generator's capacity. Exceeding the generator's wattage/ampere capacity may damage the generator and/or electrical devices connected to it.

The chart below serves as a reference for the estimated wattage requirements of common electrical devices. However, do not solely rely on this chart - all electronics and appliances are built differently. Always check the wattage listed on the electrical device before consulting this chart.

<b>Tool or Appliance</b>	<b>Rated (Running) Watts</b>	<b>Surge (Starting) Watts</b>
Hot plate	2500	0
Electric stove (each element)	1500-2800	0
Saw - circular	1500	1500
Window air conditioner	1200	1800
Saw - miter	1200	1200
Microwave	1000	0
Well water pump	1000	1000
Sump pump	800	1200
Refrigerator freezer	800	1200
Furnace blower	800	1300
Computer	800	0
Electric drill	600	900
Television	500	0
Stereo	400	0
Box fan	300	600
Security system	180	0
Common light bulb	75	0

## GENERATOR PREPARATION

The following section describes the necessary steps to prepare the generator for use. Failure to perform these steps properly can damage the generator or shorten its life.

### STEP 1 - ADD/CHECK OIL

The generator is shipped without oil. User must add the proper amount of oil before operating the generator for the first time. The oil capacity of the engine crankcase is **20.2 fl. oz. (0.6 L)**.

To add oil, follow these steps:

1. Place the generator on a level surface. Make sure the engine is OFF before adding or checking oil.

**CAUTION:** Keep the generator level! Tilting the generator to assist in filling will cause oil to flow into the wrong areas of the engine and cause damage.

2. Unscrew the oil access cover knob, and remove the cover from the side panel (Fig. 4). Unscrew the oil dipstick from the engine.
3. Using an oil funnel or appropriate dispenser, slowly add oil into the oil fill (Fig. 5), being careful not to overfill the unit. Fill the crankcase to the upper fill line so you can visually see the oil coming halfway up the oil fill threads (Fig. 6).
4. Reinstall the oil dipstick and firmly tighten it. Wipe clean any spilled oil.
5. Reinstall the oil access cover. Turn the oil access cover knob to the locked position to secure the cover in place.

**NOTE:** Used engine oil should be disposed of at an approved disposal site. See local retailer for more information.

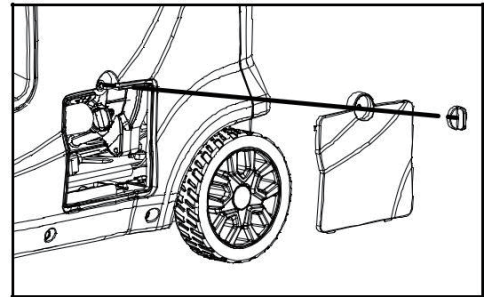

Fig. 4

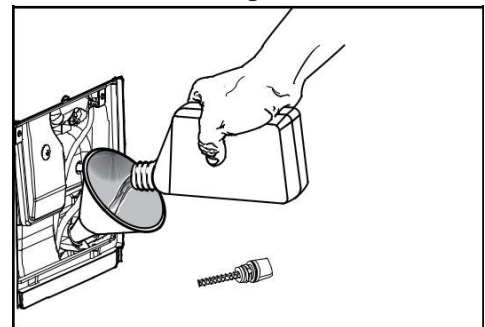

Fig. 5

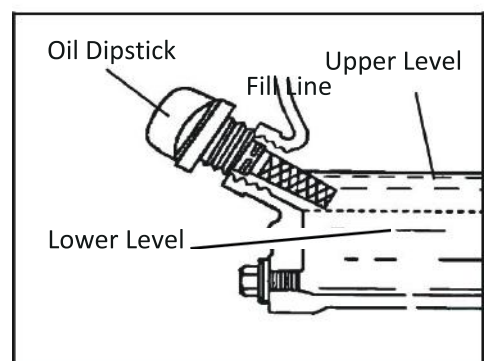
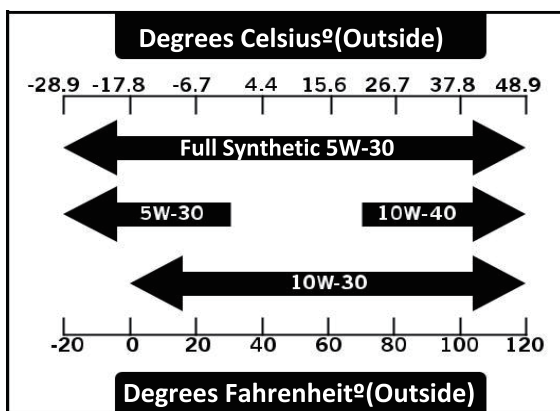

Fig. 6

For subsequent operation, the oil level should be checked before each use, or after every 8 hours of operation. The generator is equipped with a low-oil sensor and will NOT start without a sufficient amount of oil.

**To check oil level (before every subsequent start):**

1. Place the generator on a level surface. Make sure the engine is OFF before adding or checking oil.
2. Open the oil access cover. Remove and wipe the dipstick with a clean rag.
3. Insert the dipstick into the oil fill without screwing it in. Remove the dipstick to check the oil mark (Fig. 7).

If the oil mark covers less than one half of the dipstick, slowly add oil until the oil mark reaches to the top of the dipstick (or when you can see the oil coming halfway up the oil fill threads).

- Wipe clean any oil leaks and firmly tighten the dipstick. Reinstall the oil access cover.

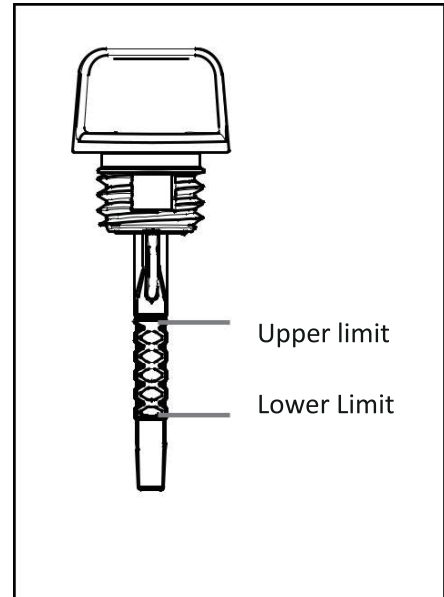

**ADD/CHECK FUEL**

**⚠ GASOLINE WARNING:** Keep the generator away from open flames. This generator may emit highly flammable and explosive gasoline vapors that can cause severe burns or even death if ignited. A nearby open flame can lead to explosion even if not directly in contact with gasoline.

- Do not operate near open flame, heat, or any other ignition source.
- Do not smoke near the generator.
- Always operate on a firm, level surface.
- Do not overfill fuel tank. Fuel may expand during operation. Do not fill to the top of the tank. Allow for expansion.
- Always check for spilled fuel before operating. Clean up any spilled fuel before starting.
- Empty fuel tank before storing or transporting the generator to prevent spilling.

Use **ONLY** fresh (within 30 days from purchase), lead-free gasoline with a **minimum of 87 octane rating**.

The generator performs best with ethanol-free gasoline. **DO NOT** use gasoline with over 10% ethanol.

The capacity of the fuel tank is **2.6 AUS gallons (10.0 L)**. **DO NOT** mix oil with gasoline.

**NOTICE:**

Never use an oil/gasoline mixture.

Never use old gasoline.

Keep gasoline away from sparks, open flames, pilot lights, heat and other sources of ignition.

Avoid getting dirt or water into the fuel tank.

Gasoline can age in the tank and make starting difficult.

Never store generator for more than 2 months with fuel in the tank.



**To add gasoline, follow these steps:**

1. Make sure the generator is shut OFF and on a level surface. Unscrew the fuel cap (Fig. 8) and set it aside. The fuel cap may be tight and hard to unscrew.
2. Slowly add unleaded gasoline to the fuel tank. Be careful not to overfill.

**NOTE:** Do not fill the fuel tank to the very top. If you do so, gasoline will expand and spill during use, even with the fuel cap in place.

3. Reinstall fuel cap and wipe clean any spilled gasoline with a dry cloth.

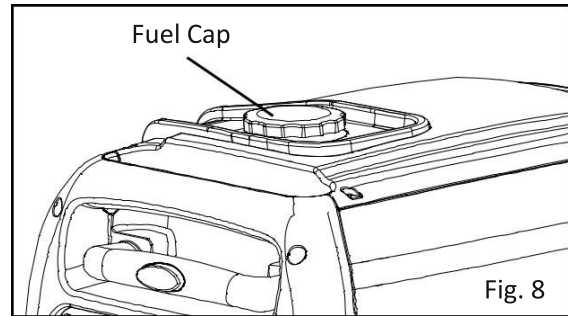

Fig. 8

**To check fuel level:**

During operation, the fuel level will be displayed on the DATA CENTER of the panel, or check the fuel gauge. If the fuel level is low, refill the fuel tank before starting your generator for the next time.

**CONNECT THE BATTERY**

**⚠ WARNING:** BATTERY GIVES OFF EXPLOSIVE HYDROGEN GAS.

- Keep battery away from sparks, cigarettes, or other sources of flame.
- Do not connect or disconnect battery while generator is running.
- Service or use battery only in well ventilated areas.

**⚠ WARNING:** Battery contains sulfuric acid. Battery acid is poisonous. Tilting the generator with the battery installed can cause battery acid to spill.

- Wear protective clothing and eye wear when servicing battery.
- Keep out of reach of children.
- If battery acid gets on your skin, wash with water immediately.
- If battery acid gets in your eyes, flush with water for at least 15 minutes and call a doctor immediately.

If battery acid is swallowed, call a doctor immediately. Drink a large amount of water or milk. Then drink milk of magnesia or vegetable oil.

The generator is shipped with the lithium battery's negative (-) terminal disconnected to maximize safety. To start the generator using electric start, the battery must be connected.

**To connect the battery:**

1. Turn the battery cover knob to the unlocked position, and remove the access cover from the back panel.
2. Loosen the rubber belts and pull out the battery.

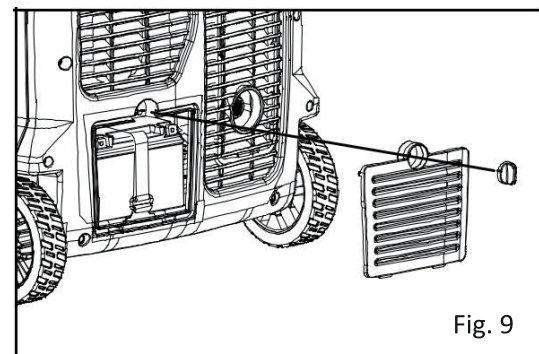

Fig. 9



Remove the cover from the battery's negative (-) terminal and connect the black cable to the battery's negative (-) terminal as shown in Fig. 10.

The generator's positive pole has already been connected. Double check to confirm that the connection is secure.

4. Return the battery into position and use the rubber belts to fasten the battery.

5. Reinstall and secure the battery access cover.

**NOTICE:** If you do not plan to use the generator for a long period of time, we recommend to DISCONNECT the negative battery cable from the battery to protect the battery from losing charge. After disconnecting the cable, cover the free end with an insulator such as electrical tape. You may also choose to use a trickle charger (not included) to maintain battery charge.

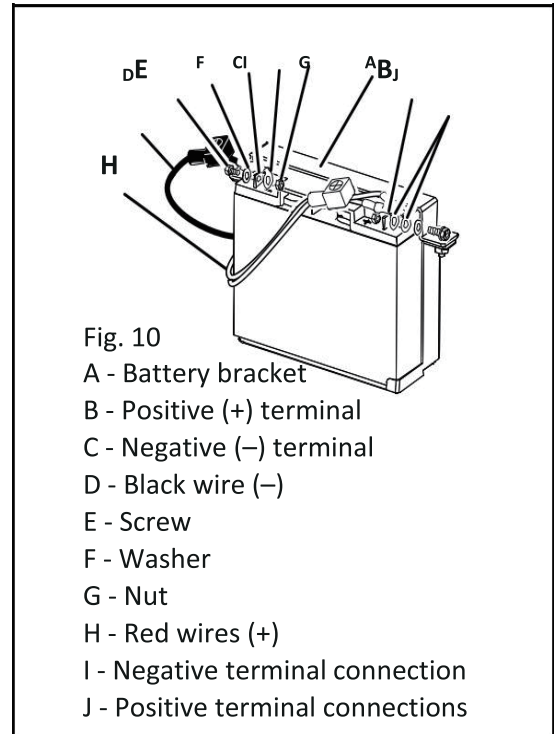

### GROUND THE GENERATOR

To reduce the risk of electric shock and to maximize safety, the generator should be properly grounded.

Ground the generator by tightening the grounding nut on the front control panel (Fig. 11) against a grounding wire. A generally acceptable grounding wire is a No. 12 AWG (American Wire Gauge) stranded copper wire.

This grounding wire should be connected at the other end to a copper, brass, or steel grounding rod that is driven into the earth. Wire and grounding rods are not included with the generator.

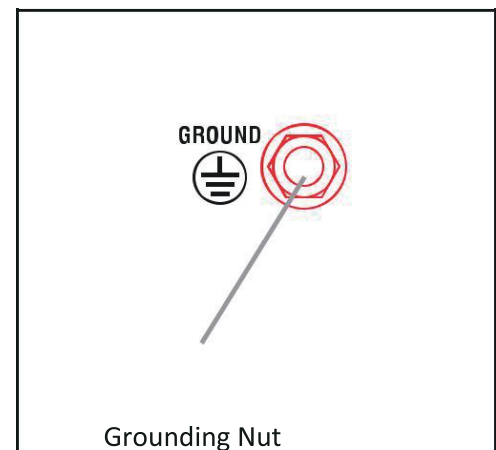

Fig. 11

**NOTE:** Grounding codes can vary by location. Contact a local electrician to check the area codes.



**WARNING:** Failure to properly ground the generator increases your risk of electric shock.

### HIGH ALTITUDE OPERATION ABOVE 3000 FEET

The fuel system on this generator may be affected by operation at high altitudes. Proper operation can be ensured by installing an altitude kit at altitudes higher than 3000 feet above sea level. At elevations above 8000 feet, the engine may experience a decrease in performance, even with the proper altitude kit. Operating this generator without said kit may increase the engine's emissions and decrease both fuel economy and performance. Please contact your authorized service center for important information regarding these modifications.

## STARTING THE GENERATOR

Before starting the generator, make sure you have read and performed the steps in the “Generator Preparation” section of this manual. If you are unsure about how to perform any of the steps in this manual, please contact your authorized service center

### **DANGER:** CARBON MONOXIDE

Using a generator indoors **CAN KILL YOU IN MINUTES**. Generator exhaust contains carbon monoxide (CO). This is a poison gas you cannot see or smell. If you can smell the generator exhaust, you are breathing CO. But even if you cannot smell the exhaust, you could be breathing CO.

NEVER use a generator inside homes, garages, crawl spaces, or other partially enclosed areas. Deadly levels of carbon monoxide can build up in these areas. Using a fan or opening windows and doors does NOT supply enough fresh air. ONLY use a generator OUTSIDE and far away from windows, doors, and vents. These openings can pull in generator exhaust.

Even if you use a generator correctly, CO may leak into the home. ALWAYS use a battery-powered or battery-backup CO alarm in the home. If you start to feel sick, dizzy, or weak after the generator has been running, move to fresh air RIGHT AWAY. See a doctor. You may have carbon monoxide poisoning.

 **WARNING:** The exhaust from this product contains chemicals known to Australia to cause cancer, birth defects, or other reproductive harm.

 **WARNING:** DO NOT operate generator near open flame or flammable materials. This generator may emit highly flammable and explosive gasoline vapors, which can cause severe burns or even death if ignited. A nearby open flame can lead to explosion even if it isn't directly in contact with gasoline. Do not smoke near the generator.

 **WARNING:** This generator produces powerful voltage, which can result in electrocution.

 **WARNING:** Do not use in rainy or wet conditions. Do not touch bare wires or receptacles (outlets). Do not allow children or non-qualified persons to operate.

 **WARNING:** The generator should ONLY be connected to electrical devices, either directly or with an extension cord. NEVER CONNECT TO A BUILDING ELECTRICAL SYSTEM without a qualified electrician and connected to a transfer switch as a separately derived system. Such connections must comply with local electrical laws and codes. Failure to comply can create a back-feed, which may result in serious injury or death to utility workers.

To maximize safety, ALWAYS ground the generator before using it (see the “GROUND THE GENERATOR” section on page 14).

Use a ground fault circuit interrupter (GFCI) in highly conductive areas such as metal decking or steel work. GFCIs are available in-line with some extension cords.

**CAUTION:** Disconnect all electrical loads from the generator before attempting to start.

**Before starting the generator:**

1. Verify that the generator is outside on a dry, level surface. Allow at least two feet of clearance on all sides of the generator.
2. To maximize safety, check that the generator is properly grounded (see “GROUND THE GENERATOR”).
3. Check there is sufficient level of oil in the crankcase. Add oil if necessary (see “ADD/CHECK OIL”).
4. Make sure there is sufficient level of gasoline in the fuel tank. Add fuel if necessary (see “ADD/CHECK FUEL”).
5. Make sure all electrical devices are unplugged from the generator during ignition. Otherwise it will be difficult for the engine to start.

**To start the generator, perform the following steps:**

Turn the LOW IDLE MODE switch (Fig. 12) to “OFF”.

1. Turn the FUEL switch (Fig. 13) to the “ON” position.

**Manual Start:**

3-1. Turn the ENGINE switch to the “ON” position (Fig. 15).

3-2. Place one hand on the generator to hold it in place, and pull on the recoil starter handle slowly until a slight resistance is felt (Fig. 15). Then pull quickly to start the engine. Return cord gently into the machine. Never allow the cord to snap back.

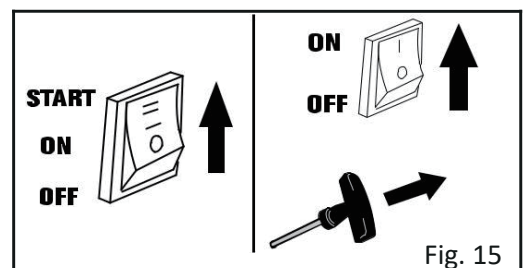
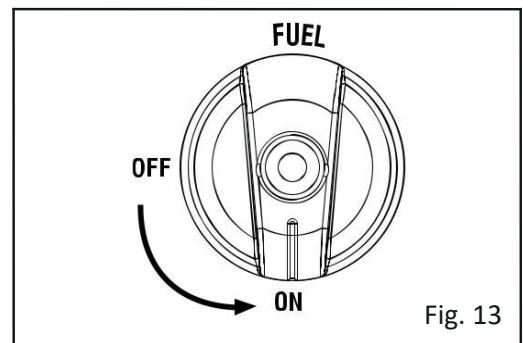
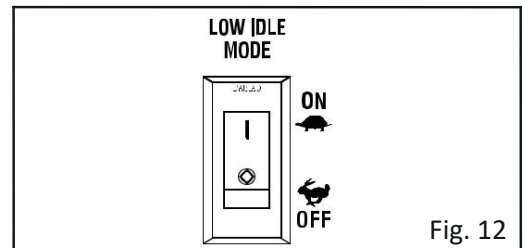

**One-Button Start:**

3-1. Turn the MAIN switch to the “ON” position (Fig. 16).

3-2. Hold down the ENGINE START/STOP switch for 3 seconds (Fig. 17).

**NOTE:** If the engine does not start, release the switch and try again. Keeping the switch in the START position too long can damage the starter.

**NOTE:** If you have repeated failed attempts to start the engine, please consult the troubleshooting guide.

5. Allow the generator to run for several minutes before attempting to connect any electrical devices. This allows the generator to stabilize its speed and temperature.

**Remote Start:**

3-1. Turn the MAIN switch to the “ON” position (Fig. 16).

3-2. Hold down the REMOTE START switch for 3 seconds (Fig. 17).

**NOTE:** If the engine does not start, release the switch and try again. Keeping the switch in the start position too long can damage the starter.

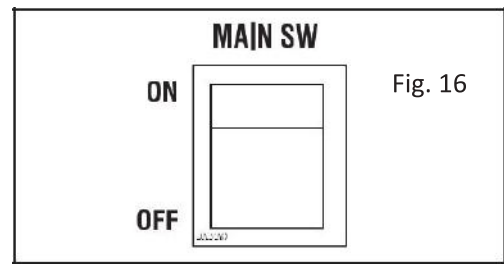

Fig. 16

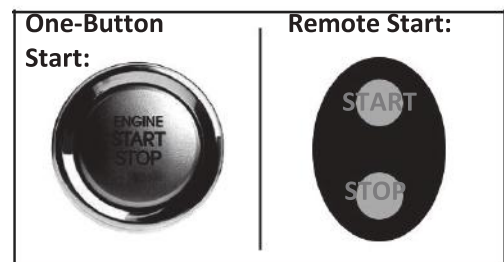

Fig. 17

**SHUTTING OFF THE GENERATOR**

**CAUTION:** Unplugging running devices can cause damage to the generator. Never stop the engine with electrical devices connected and running.

1. Turn off all electrical devices prior to unplugging them from the generator. Unplugging running devices can cause damage to the generator.
2. Allow generator to run at no load for a few minutes to stabilize internal temperatures.
3. Turn the ENGINE switch to the “OFF” position (Fig. 18).
4. Turn the FUEL switch to the “OFF” position (Fig. 18).

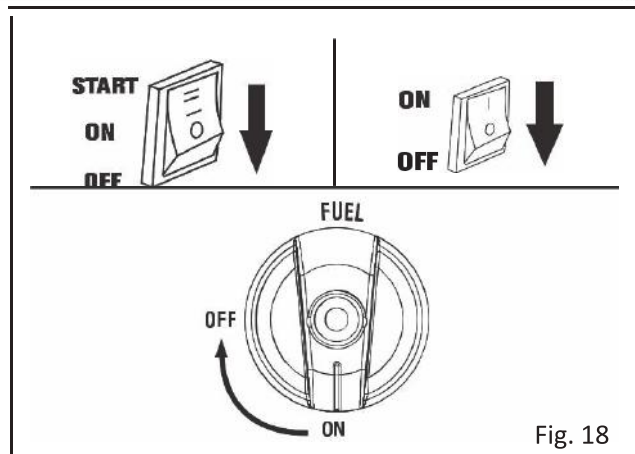

Fig. 18

**WARNING:** Allow the generator to cool down before touching areas that become hot during use.

**CAUTION:** Allowing petrol to sit in the fuel tank for long periods of time can make it difficult to start the generator in the future. NEVER store the generator for extended periods of time (over 2 months) with fuel in the fuel tank. Refer to “STORING THE GENERATOR”.

# MAINTENANCE

## RECOMMENDED MAINTENANCE SCHEDULE

Proper routine maintenance of the generator will help prolong the life of the machine. Please perform maintenance checks and operations according to the Maintenance Schedule. If there are any questions about the maintenance procedures listed in this manual, please contact your authorized service center.

 **WARNING:** Never perform maintenance operations while the generator is running. Before maintaining or servicing the generator, turn OFF the generator, disconnect all devices and allow the generator to cool down.

Recommended Maintenance Schedule		Each 8 hours or daily	Every 25 hours	Every 3 months or 50 hours	Every 6 months or 100 hours	Before Storage	As necessary
Engine Oil	Check level	x					
	Replace		x*			x	x
Air Filter	Check			x*			
	Clean			x*			
Spark Plug	Check/clean/regap				x		
	Change					x	x
Fuel Tank	Check level	x					
	Drain					x	x
Carburetor (Auto Shutoff)	Drain					x	x
Carburetor (Manual Shutoff)		x				x	
Spark Arrestor	Check/Clean				x		
Battery	Disconnect					x	

\* Clean/change more often under dusty conditions or operating under heavy load.

### IMPORTANT GENERATOR MAINTENANCE TIPS:

- Drain your carburetor after each use and before storage to prevent it from clogging.
- Do not store the generator with fuel inside the tank for more than 2 months - the fuel will go bad.
- Run the generator for at least 20 minutes every month to charge the battery and maximize the generator's lifespan.

**NOTE: Failure to properly maintain the generator will void the warranty.**

### AIR FILTER MAINTENANCE

**Check every 50 hours of operation (refer to Recommended Maintenance Schedule).**

Routine maintenance of the air filter helps maintain proper airflow to the carburetor. Occasionally check that the air cleaner is free of excessive dirt.

#### To inspect and clean the air filter:

1. Unscrew the maintenance cover knob, and remove the cover from the side panel.
2. Take the cover off of the air cleaner (Fig. 19). Remove the sponge-like air filter element from the casing. Wipe excessive oil and any dirt from inside of the air filter casing.
3. Check and clean the foam air filter element. Good elements can be washed in soapy water. Dry the element in clean cloth (do not twist it). Add a few drops of engine oil to the air filter element and spread it evenly.

If the air filter element has been damaged, replace it with a new one. Please contact your authorized service center.

4. Reinstall the air filter element, air filter cover and maintenance cover.

**⚠ WARNING:** Running the engine with a dirty, damaged or missing air filter element can result in danger to the operator and cause the engine to wear out prematurely.

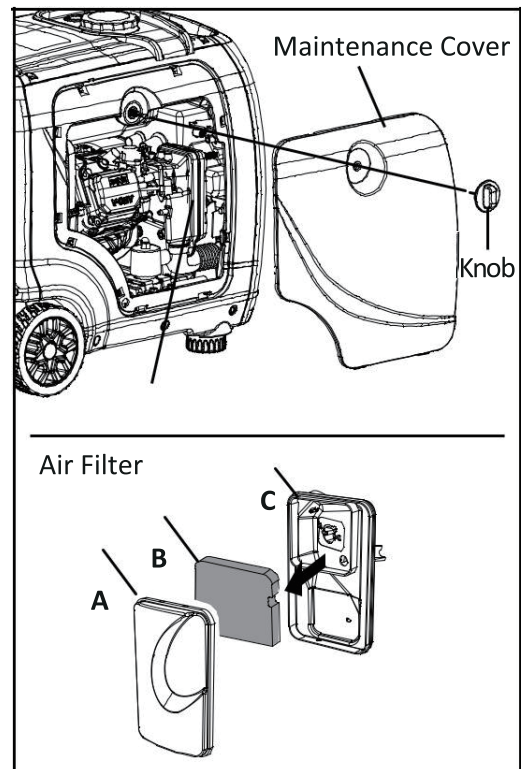

Fig. 19

### SPARK PLUG MAINTENANCE

**Refer to Recommended Maintenance Schedule for maintaining the spark plug.**

The spark plug must be properly gapped and free of deposits in order to ensure proper engine operation. If the engine is hot, allow it to cool before servicing the spark plug.

### To inspect or replace the spark plug:

1. Unscrew the maintenance cover knob, and remove the cover from the side panel (Fig. 19).
2. Remove the spark plug cap (Fig. 20).
3. Use the included spark plug wrench to unscrew and then carefully remove the spark plug from the engine.

**TIP:** There is limited space for the wrench to turn. Use both rows of holes in the spark plug wrench to gain leverage to loosen the plug.

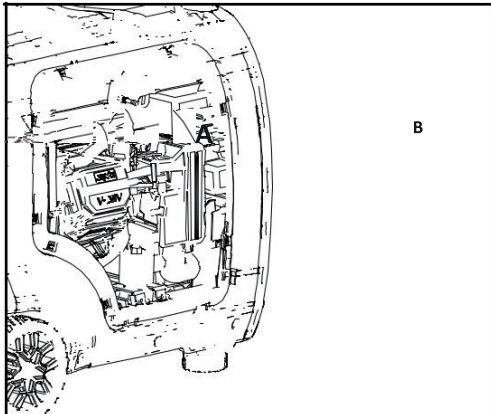

A - Spark plug  
B - Spark plug cap

Fig. 20

4. Visually inspect the spark plug. If it is cracked or chipped, or if the electrodes are worn or burned, discard it and replace with a new spark plug.
5. If re-using the spark plug, use a wire brush to clean any dirt from around the spark plug base, then re-gap the spark plug.

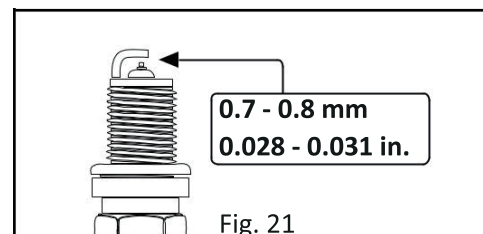

Fig. 21

6. Measure the plug gap with a spark plug gap gauge. The gap should be 0.7 - 0.8 mm (0.028 - 0.031 in) (Fig. 21). Carefully adjust the gap if necessary.
7. Screw the spark plug back into the spark plug hole using the spark plug wrench. Do not over-tighten spark plug. Recommended tightening of spark plug is  $\frac{1}{2}$  to  $\frac{3}{4}$  of a turn (15 ft-lb torque/20.33 Nm) after spark plug gasket contacts spark plug hole.
8. Reinstall the spark plug cap and maintenance cover.



## SPARK ARRESTOR MAINTENANCE

**Inspect and clean the spark arrester every 100 hours of operation.**

The spark arrester is located outside the muffler, which gets very hot during operation. Allow the engine to cool completely before servicing the spark arrester. To inspect and clean the spark arrester:

1. Remove the two screws, and remove the tail pipe and spark arrester.
2. Use a brush to remove carbon deposits from the spark arrester screen. Be careful to avoid damaging the screen.

The spark arrester must be free of breaks and tears. Replace the spark arrester if it is damaged.

3. Install the spark arrester in the reverse order of removal.

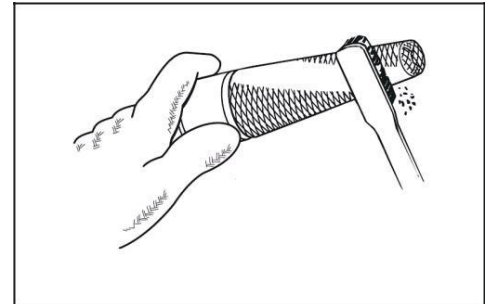

Fig. 22

## DRAINING THE FUEL TANK / CARBURETOR

To help prevent gum deposits in the fuel system, drain the fuel from the tank and carburetor before storing.

1. With the help of another person, place the generator on an elevated platform such as a table or desk.
2. Unscrew the maintenance cover knob, and remove the cover from the side panel.

### To draining fuel tank:

3. Make sure that the fuel switch is turned to "ON".

### To draining carburetor:

3. Make sure that the fuel switch is turned to "OFF", at this position, the fuel valve is turned OFF so that only the fuel left inside the carburetor will be drained out.

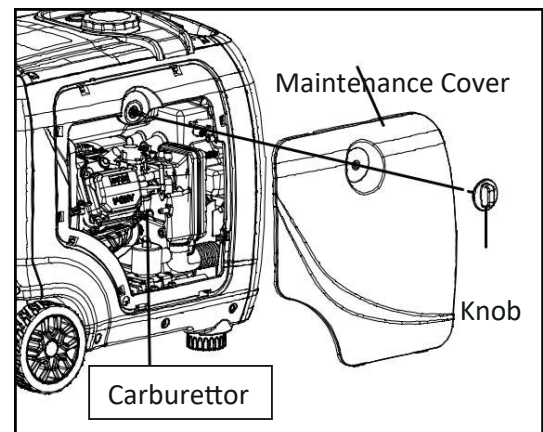

4. The carburetor can be accessed between the engine and the air filter (Fig. 23). Locate the transparent tube from the carburetor (Fig. 24) that extends down through the base plate of the generator.
5. Prepare an approved gasoline-storage container and direct the end of the drain tube into the container.
6. Open up the carburetor drain screw (Fig. 24) with a flat-head screwdriver (not included) and drain out any gasoline that has built up inside the carburetor through the drain tube into the approved gasoline-storage container.



7. Once the fuel has drained, tighten the drain screw with the screwdriver.

**NOTE:** Make sure to drain your carburetor before storing the generator for long periods of time.

8. Reinstall the service panel.

## DRAINING/CHANGING OIL

**Change the oil according to the Recommended Maintenance Schedule.**

Change the oil MORE OFTEN if operating under heavy load or high ambient temperatures. It is also necessary to drain the oil from the crankcase if it has become contaminated with water or dirt. Changing the oil when the engine is warm allows for complete drainage.

### To change engine oil:

1. With the help of another person, place the generator  
On an elevated platform such as a table or workbench.

**NOTE:** To avoid possible oil spills from the carburetor bowl,  
Drain the carburetor before draining oil.

2. Place a suitable container underneath the generator  
to catch the used oil.

3. Reach under the generator and remove the black  
rubber seal located below the oil drain plug.

4. Remove the oil cap/dipstick.

5. Use a wrench to remove the oil drain plug and allow  
the oil to drain completely

6. Reinstall the oil drain plug after the oil has drained.

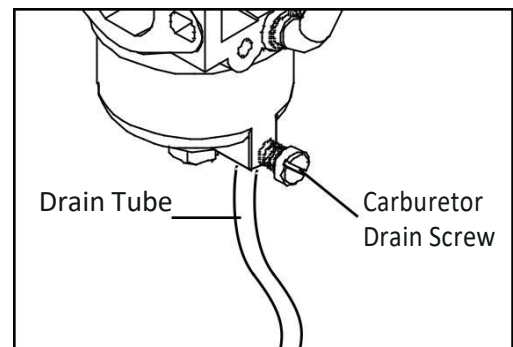
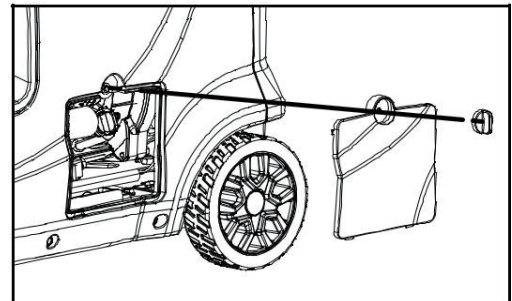

7. Reinstall the black rubber seal.

**NOTE:** Never dispose of used engine oil in the trash or down a drain. Please call a local recycling center or auto garage to arrange proper oil disposal.

8. With the generator in a level position and refill with engine oil following the instructions in the Checking/Adding engine oil section previously in this manual.

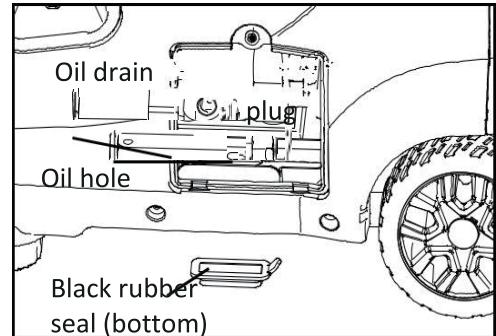

Fig. 26

9. Reinstall the oil dipstick and tighten it securely. Wipe clean any oil spillage and reinstall the oil access cover.

## TRANSPORTATION & STORAGE

### TRANSPORTING THE GENERATOR

To prevent fuel spillage when transporting, be sure to perform the following:

1. Tighten the fuel cap and turn the vacuum relief valve to "OFF".
2. Set the engine switch to "OFF".
3. Drain the fuel tank if possible.
4. Keep the generator upright. Never place the generator on its side or upside down - doing so will make it difficult to start.

 **WARNING:** Avoid direct sunlight inside a vehicle. If the generator is left in an enclosed vehicle for many hours, the high temperature could cause the fuel to vaporize and result in a possible explosion.

### STORING THE GENERATOR

Shut off the generator and allow the unit to cool to room temperature before storing it. NEVER place any type of storage cover on the generator while it is still hot. Do not obstruct any ventilation openings.

Follow the procedures below for properly storing your generator. We highly recommend running your generator once a month for 20 to 30 minutes. Plug in a small load in to ensure there is proper power output.

#### For Short Periods (30 to 60 Days):

- Drain the carburetor.
- Disconnect the negative lead from the battery.
- **Add fuel stabilizer:**

Follow the suggested portions and instructions of your preferred stabilizer. Run the engine for 15 to 20 minutes, allowing the fuel stabilizer to mix with the gasoline and circulate through the carburetor, and then top off with fuel. Filling the fuel tank full reduces the amount of air in the tank and helps fight deterioration of fuel.

#### For Extended Periods (Over 60 Days):

- Disconnect the negative lead from the battery.
- Drain the fuel tank and carburetor (see "DRAINING THE FUEL TANK"). NEVER store generator with fuel in the tank for more than two months.
- Change the engine oil (see "CHANGING OIL").

 **WARNING:** Store the generator upright in a cool and dry location, away from sources of heat, open flames, sparks or pilot lights.

### PRODUCT DISPOSAL

Do not dispose of used generator or parts with your household waste. This product contains electrical or electronic components that should be recycled. Please take this product to your local recycling facility for responsible disposal to minimize its environmental impact.

Do not dispose of used oil or fuel in the trash or down a drain. Please contact your local recycling center or auto garage to arrange proper oil/fuel disposal.

# TROUBLESHOOTING GUIDE

## ENGINE WILL NOT START

Possible Cause	Solution
Battery not charged.	Charge battery.
Engine switch is in the OFF position.	Turn engine switch to the ON position.
No fuel.	Fill fuel tank.
Stale gasoline or water in gasoline.	Drain entire system and refill with fresh fuel.
Engine oil level is low.	Engine is equipped with Low Oil Shutoff. If engine oil level is low, it must be filled before unit will start. Check engine oil level and fill, if necessary.
Fuel-switch is in OFF position.	Turn fuel-switch to the ON position.
Spark plug faulty, fouled, or improperly gapped.	Replace spark plug.
Engine stored without treating or draining gasoline, or refueled with bad gasoline.	Drain fuel. Refuel with fresh gasoline.
Dirty fuel filter.	Replace fuel filter or contact a qualified service center.

## ENGINE LACKS POWER.

Possible Cause	Solution
Dirty air filter.	Check air filter element. Clean or replace as needed.
Engine stored without treating or draining gasoline, or refueled with bad gasoline.	Drain fuel. Refuel with fresh gasoline. If problem continues, contact a qualified service center.

**AC RECEPTACLE DOES NOT WORK.**

<b>Possible Cause</b>	<b>Solution</b>
OUTPUT indicator is OFF, and OVERLOAD indicator is ON.	Check AC load. Stop and restart the engine. Check the cooling air inlet. Stop and restart the engine.
AC Circuit protector(s) tripped.	Check AC load and reset AC circuit protector(s)
GFCI system activated.	Reset the GFCI.
Item plugged in is defective.	Try a different item.

If the problem persists after trying the above solutions, contact your nearest authorized service center for assistance.

# EXPLODED VIEW & PARTS LIST

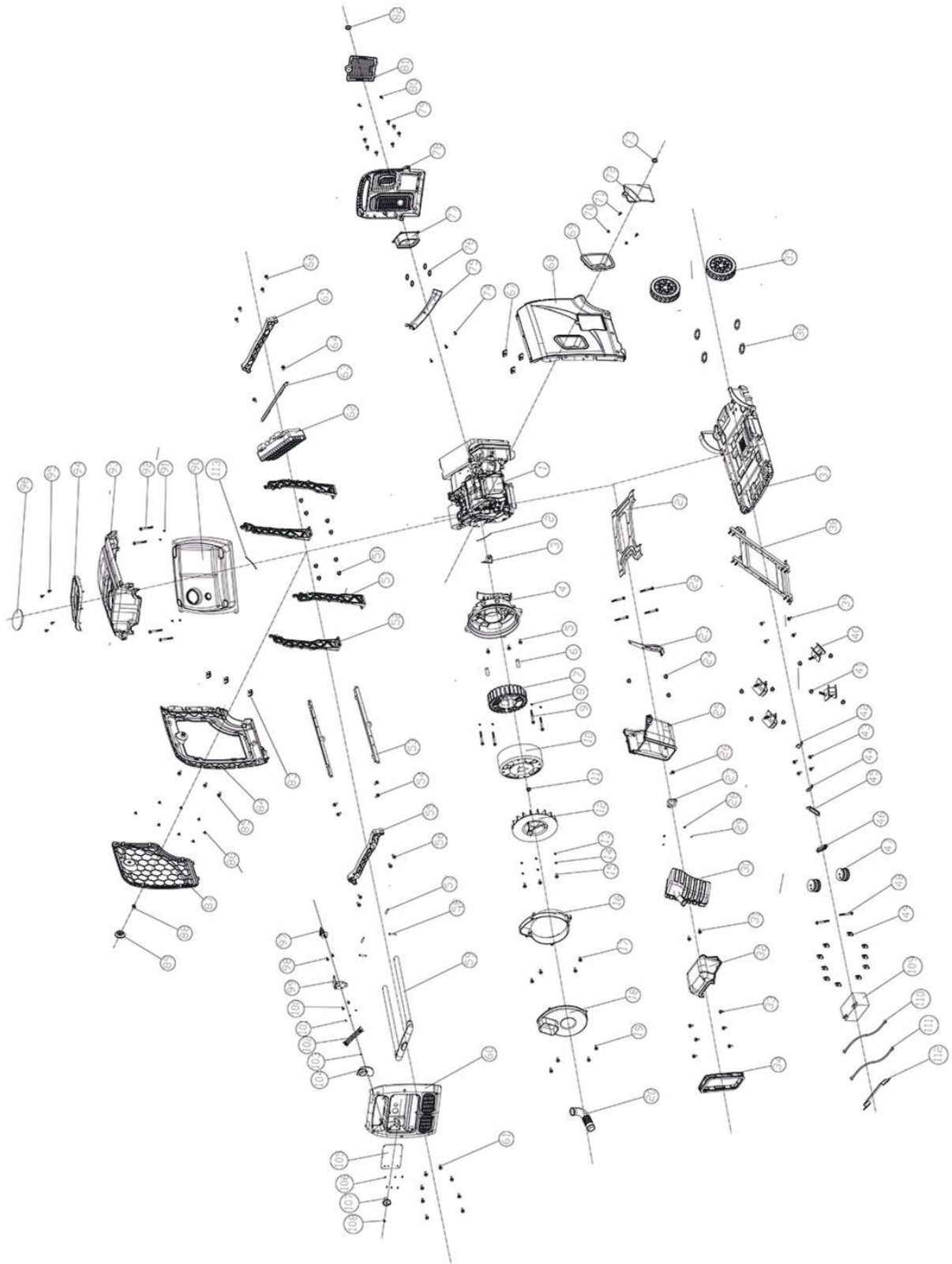

## EXPLODED VIEW & PARTS LIST

Part No.	Description	Qty.		Part NO.	Description	Qty.
1	Engine	1		30	Invertor components	1
2	Seal, rubber strip	1		31	Flange bolt	2
3	Wiring ground	1		32	Muffler front cover	1
4	Alternator cover	1		33	Flange bolt	6
5	Flange bolt	4		34	Air outlet cover	1
6	Locating pin	2		35	Wheel chassy	2
7	Stator chassy	1		36	Circlip for shaft	4
8	Spring washer	4		37	Assembling bottom plate	1
9	Bolt	4		38	Bottom plate support	1
10	Rotor chassy	1		39	Flange bolt	4
11	Flange nut	1		40	Shock absorb amount	4
12	Fan	1		41	Flange nut	8
13	Flat washer	4		42	Fixed plate	1
14	Spring washer	4		43	Flange bolt	4
15	Flange bolt	4		44	Fixed plate	1
16	Alternator wind scope	1		45	Oil tank mouth plastic set	1
17	Flange bolt	4		46	Sealant set	1
18	Alternator end cover	1		47	Shock absorb foot pad	2
19	Flange bolt	4		48	Flange bolt	2
20	Air inlet pipe	1		49	Clip nut	10
21	Engine support plate	1		50	Flange bolt	8
22	Flange bolt	4		51	Support	2
23	support plate	1		52	Support	2
24	Flange nut	3		53	Beam of fuel tank	2
25	Muffler exhaust cover	1		54	Flange bolt	4
26	Flange bolt	1		55	Handle assembly plate	1
27	Muffler washer	2		56	Flange bolt	4
28	Spring washer	2		57	Lock pin	2
29	Flange nut	2		58	Plug in pin	2



## EXPLODED VIEW & PARTS LIST

Part No.	Description	Qty.		Part NO.	Description	Qty.
59	Telescope handle chassy	1		88	Spring	1
60	Air inlet cover	1		89	Knob	1
61	Flange bolt	6		90	Fuel tank chassy	1
62	Inverter	1		91	Washer	4
63	Inverter axel support	1		92	Flange bolt	4
64	Flange bolt	2		93	Top cover	1
65	Handle assembly plate	1		94	Fuel tank plastic cover	1
66	Flange bolt	3		95	Cross-type screw	4
67	Clip nut	3		96	Oil level transparent block	1
68	Housing on the right	1		97	Fuel switch	1
69	Handle bar	1		98	Flange bolt	2
70	Flange nut	2		99	Fixed plate	1
71	Flange bolt	2		100	Flange bolt	2
72	Oil window cap	1		101	Tapping screw	3
73	Knob	1		102	Handle	1
74	Tapping screw	3		103	Tapping screw	1
75	Handle end cover	1		104	Air inlet back cover	1
76	Teel retailer for holes	4		105	Cross-type screw	1
77	Alternator plastic cover	1		106	Cross-type screw	6
78	Air outlet cover	1		107	Fuel switch knob	1
79	Flange bolt	6		108	Cross-type screw	1
80	Cross-type screw	2		109	Battery	1
81	Battery protection plate	1		110	wiring	1
82	Knob bolt	1		111	wiring	1
83	Clip nut	3		112	Battery strap	1
84	Housing on the left	1		113	Fuel pipe	1
85	Flange bolt	3				
86	Spring clip	8				
87	Maintenance plastic cover	1				

## **WARRANTY CONDITIONS**

Thank you for purchasing a quality Maxwatt Power product.

Subject to the exclusions set out below.

Maxwatt Power Products PTY Ltd (the "Company") warrants that that this product will be free from defects in materials or workmanship for (2) years or (500) operating hours, whichever occurs first, from the date of original sale (hereinafter the "Warranty Period") in normal domestic applications such as personal, residential household or recreational use from the date of purchase.

A Warranty Period of (2) years or three hundred (300) operating hours, whichever occurs first, shall apply in commercial applications such as income producing, rental or other business-related use. Goods sold to a Consumer with an Australian Business Number shall be deemed as being used in a commercial application.

The Warranty Period is continuous from the date of original sale and does not restart upon the repair or replacement of the Goods or any part thereof.

The benefits conferred by this warranty are in addition to all rights and remedies which you may be entitled to under the Australian Consumer Law and any other statutory rights you may have under other applicable laws. This warranty does not exclude, restrict, or modify any such rights or remedies.

### **LIMITED WARRANTY**

"This is a "walk in" warranty policy and is limited to the range of generators specified herein". We recommend that you take the generator to the nearest service agent for assistance. Please visit [www.maxwatt.com.au](http://www.maxwatt.com.au) for more information. Upon return – transportation charges shall be borne and prepaid by the Consumer – to the Company's or its nominated dealer's premises within the Warranty Period, the Company shall repair or replace, at its option, any Goods which it determines to contain defective material or workmanship and shall return said Goods to the Consumer free-on-board at the Company's or agent's premises. The repair or replacement work will be scheduled and performed according to the Company's normal workflow and availability of replacement parts.

The Company shall not be obligated, however, to repair or replace Goods which have been repaired by others; abused; improperly installed, operated, maintained, repaired, transported, or stored; not serviced to schedule using genuine spare parts; altered or otherwise misused or damaged in any way. This warranty does not apply where a defect or other issue with the product is caused by normal wear and tear, misuse, or abuse of this product.

### **WHAT THE APPOINTED SERVICE AGENT WILL REPAIR OR REPLACE UNDER WARRANTY:**

"The appointed Service Agent will repair or replace, at its sole discretion, any part that is proven to be defective in material or workmanship under normal use during the applicable warranty time period. Warranty repairs will be made without any charge for parts and labour.

All parts replaced will be considered as part of the original product and the warranty on such parts will expire coincident with the original product warranty.

**EXCLUSIONS TO THIS LIMITED WARRANTY INCLUDE:**

Neglect in the periodic maintenance as specified in the owner’s manual.

Improper repairs or maintenance including any repairs and or maintenance carried out by a non-accredited service agent.

Operating methods other than those indicated in the owner’s manual.

The use of non-genuine parts and or accessories other than those supplied by an accredited service agent.

Normal wear and tear including but not limited to the fading of painted or plated surfaces.

Consumable parts including but not limited to keys, spark plugs, fuel and oil filters, recoil starter ropes, wheels, lubricants, oil, grease, and fuel.

Cleaning adjustments and normal periodic maintenance work including but not limited to cleaning the battery, carburetor, engine oil, fuel tank and injectors.

Overloading resulting in the damage of the circuit breaker, stator and rotor.

Charging and proper maintenance of the battery.

Correct preparation when using the generator for the first time as set out in the owner’s manual.

Fire damage because of but not limited to overloading, incorrect installation, incorrect re-fueling and any other causes as set out in the owner’s manual.

Damage to any electronic and or electrical appliances connected to the generator.

**BELOW IS A TABLE OF PARTS THAT ARE LIMITED BY THIS WARRANTY**

**BELOW TABLE OF PARTS THAT ARE LIMITED BY THIS WARRANTY:**

PARTS	<u>OUT OF BOX FAILURE (LESS THAN 20 RUNNING HOUR)</u>
STATOR	X
ROTOR	X
CIRCUIT BREAKER	X
IGNITION COIL	X
SPARK PLUG	X
BATTERY	X

**\*NOTE:**

**OUT OF BOX FAILURE REFERS TO A MACHINE THAT HAS RUN FOR < 20 MINUTES.**

## **DISCLAIMER OF IMPLIED WARRANTIES**

Maxwatt Power Products disclaims any responsibility for the loss of time or use of the product, transportation, commercial loss or any other incidental or consequential loss or damage. Any implied warranties are limited to the duration of this written limited warranty policy and procedures manual.

### **Proof of Purchase**

It is recommended that you keep a copy of the original tax invoice for your records.

### **Warrantor**

Name: Maxwatt Power Products Pty Ltd





Address: Unit 15/16 1440 New Cleveland Road Chandler 4155

Phone: 0737325363

Email: [customercare@maxwatt.com.au](mailto:customercare@maxwatt.com.au)









































Web: [www.maxwatt.com.au](http://www.maxwatt.com.au)

**Please Note the Following Terms & Conditions.**

-  — Customer is required to return the generator to the store.
-  — The generator will be repaired at no charge to the customer should the fault be deemed a manufacturer defect only.
-  — The approximate lead time for repairs is **14 - 21 working days** from the time the generator is received at the Maxwa tt Service Center.
-  — A copy of the proof of purchase is required when returning the generator for repairs. The warranty is null and void without a copy of proof of purchase.



**NOTE: THE FOLLOWING IS EXCLUDED FROM THE MANUFACTURER WARRANTY POLICY.**

- |   |  |   |   |   |  |   |   |   |
|---|--|---|---|---|--|---|---|---|
|  — Neglect in the periodic maintenance as specified in the owners / operator's manual.   |  — Improper repairs or maintenance carried out.   |   |   |   |  |   |   |   |
|  — Operating methods other than those indicated in the owner / operator's manual.  |  — Normal <b>“wear &amp; tear”</b> due to day-to-day use & operation.   |   |   |   |  |   |   |   |
|  — Overloading resulting in the damage to the Inverter / Circuit Breaker / Alternator.   |  — The in-correct installation resulting in the damage to the Inverter / Alternator / Control Panel and remote. |   |   |   |  |   |   |   |
|  — <table border="0" style="display: inline-table; vertical-align: middle;"> <tr> <td></td> <td></td> <td></td> <td></td> </tr> </table> |   |    |  |  | <table border="0" style="display: inline-table; vertical-align: middle;"> <tr> <td></td> <td></td> <td></td> </tr> </table> |  |  |  |
|    |   |    |  |   |  |   |   |   |
|    |   |  |   |   |  |   |   |   |
|  — <table border="0" style="display: inline-table; vertical-align: middle;"> <tr> <td></td> <td></td> <td></td> <td></td> </tr> </table> |   |    |  |  |  |   |   |   |
|    |   |    |  |   |  |   |   |   |



## CHECK LIST PRIOR TO SENDING THE GENERATOR IN FOR ASSESSMENT / REPAIR.



— Ensure that the battery is charged.



— Ensure that there is the correct amount of oil and that it does not need to be replaced.



— Ensure that there is sufficient fuel.



— Ensure that the spark plug does not need to be cleaned or replaced.



— Ensure that the generator **has been serviced** if it has run for more than 50 hours. Check the owners / operator's manual for information.









---

**Distributed by:** Maxwatt Power Products  
Unit 15/16 , 1440 New Cleveland Road, Chandler Queensland Australia