

# **SUNLIGHT™**

SOLAR LIGHTING CONTROLLER

---

## **OPERATOR'S MANUAL**

### **SUNLIGHT MODELS INCLUDED IN THIS MANUAL**

---

- **SL-10**                      10A / 12V
  - **SL-10-24V**                10A / 24V
  - **SL-20**                        20A / 12V
  - **SL-20-24V**                20A / 24V
- 



1098 Washington Crossing Road  
Washington Crossing, PA 18977 USA

## SPECIFICATION SUMMARY

	SL-10	SL-20	24 Volt	
<b>System Voltage</b>	12	12	24	V
<b>Maximum Voltage</b>	30	30	50	V
<b>Rated Solar Input</b>	10	20	n/a	A
<b>PV Short Circuit Rating</b>	12.5	25	n/a	A
<b>Rated Load</b>	10	20	n/a	A
<b>25% Current Overload</b>	5	5	n/a	minutes
<b>Regulation Voltage:</b>				
Sealed PWM	14.1	14.1	28.2	V
Flooded PWM	14.4	14.4	28.8	V
<b>LVD</b>	11.7	11.7	23.4	V
<b>LVD Reconnect</b>	12.8	12.8	25.6	V
<b>Temp Compensation</b>	-27	-27	-54	mV/°C
<b>Self-consumption</b>	8	8	9	mA
<b>Ambient Temp Range</b>	-40 to 60	-40 to 60	-40 to 60	°C

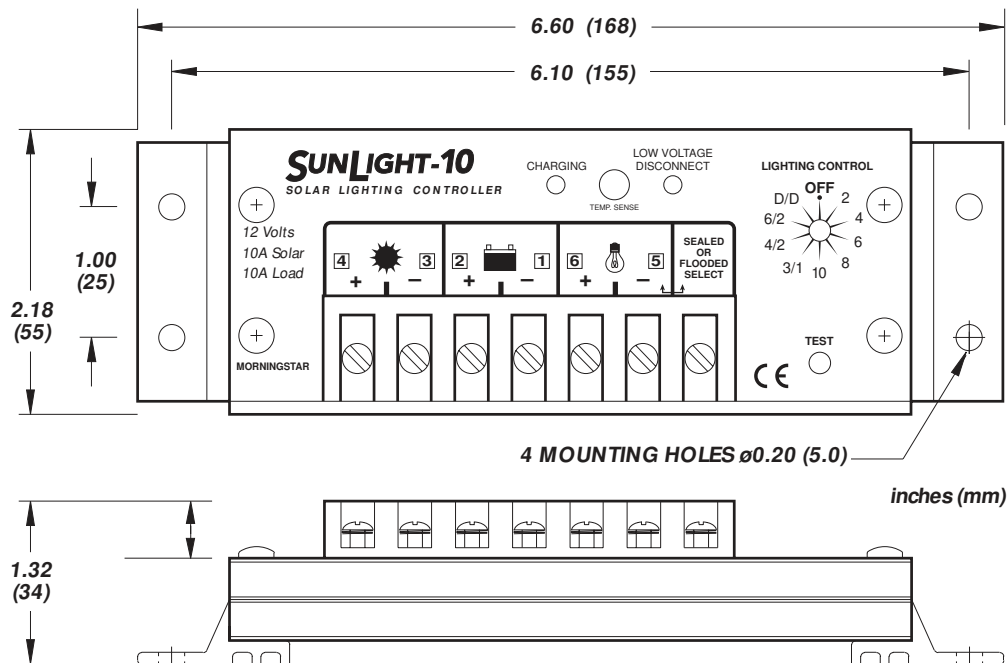

## **CONTENTS**

<b>1.0</b>	<b>GENERAL INFORMATION</b>	1
<b>2.0</b>	<b>IMPORTANT SAFETY INSTRUCTIONS</b>	2
<b>3.0</b>	<b>QUICK START INSTRUCTIONS</b>	2
<b>4.0</b>	<b>LIGHTING CONTROL OPTIONS</b>	3
<b>5.0</b>	<b>LED INDICATORS</b>	4
<b>6.0</b>	<b>INSTALLATION INSTRUCTIONS</b>	4
6.1	Ratings and Limits	4
6.2	Polarity Protection	5
6.3	Brownout Protection	5
6.4	Installation Procedure	5
<b>7.0</b>	<b>OPERATION</b>	8
7.1	Select Lighting Control Option	8
7.2	Test Button	8
7.3	Operator Tasks	9
7.4	Operation and Functions	9
7.5	Inspection and Maintenance	12
<b>8.0</b>	<b>TESTING AND TROUBLESHOOTING</b>	12
8.1	Testing with a Power Supply	12
8.2	Troubleshooting	13

### **1.0 GENERAL INFORMATION**

Thank you for selecting the SunLight™ solar lighting controller. The SunLight is an advanced design using a microcontroller for digital accuracy and fully automatic operation. The PWM battery charging has been optimized for longer battery life.

Many specifications of the SunLight are unique. Although the SunLight is very simple to use, please take the time to read this operator's manual and become familiar with the controller. This

will help you to make full use of the many advantages the SunLight can provide to your solar lighting system.

## **2.0 IMPORTANT SAFETY INSTRUCTIONS**

- **SAVE THESE INSTRUCTIONS**—This manual contains important instructions that should be followed during installation and maintenance of the SunLight controller.
- **WARNING**—Be very careful when working with batteries. Lead acid batteries can generate explosive gases, and short circuits can draw thousands of amps from the battery. Read all instructions provided with the battery.
- Do not exceed the voltage or current ratings of the controller. Use only with a 12 volt or 24 volt battery.
- **DO NOT** short circuit the PV array or load while connected to the controller. This will **DAMAGE** the controller.
- The controller should be protected from direct sunlight. Ensure adequate space for air flow around the controller.
- Pressure terminal connectors are not required. Use only copper wire with minimum 75°C insulation rating and between 10 AWG (5.2 mm<sup>2</sup>) and 14 AWG (2.1 mm<sup>2</sup>) gage.
- The negative system conductor should be properly grounded. Grounding should comply with local codes.

## **3.0 QUICK START INSTRUCTIONS**

This section provides a brief overview of how to get started using the SunLight controller. However, please review the entire manual to ensure best performance and years of trouble-free service.

1. Mount the SunLight to a vertical surface. Allow space above and below the controller for air flow.
2. Make sure the PV and load currents will not exceed the ratings of the SunLight model being installed.
3. The 6 system connections to the SunLight terminals are numbered on the label. It is recommended that the connections be made in order from 1 to 6.
4. Connect the **BATTERY** first. Use care that bare wires do not touch the metal case of the controller.
5. Connect the **SOLAR** (PV array) next. The green LED indicator will light if sunlight is present.

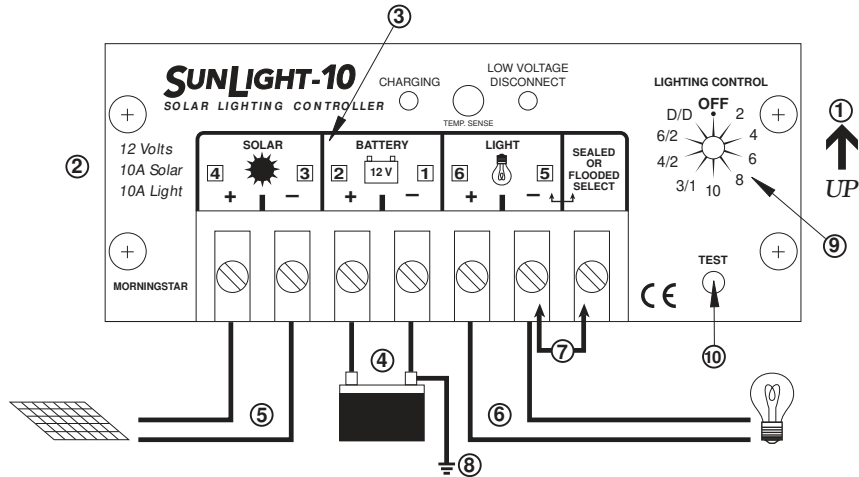

6. Connect the **LIGHT** last. If the red LED indicator lights, the battery capacity is low and should be charged before completing the system installation (Refer to Section 6.4).
7. The controller is shipped with a terminal jumper installed. This sets the controller for charging **SEALED** batteries.  
If a **FLOODED** battery is being used, simply remove the jumper to optimize the battery charging for a flooded battery. If the jumper is connected again, the charging will return to the set-points for a sealed battery (Refer to Section 6.4.)
8. For most effective surge protection, it is recommended that the negative system conductor be properly grounded.
9. Turn the rotary **LIGHTING CONTROL** switch to the lighting option desired (Refer to Section 7.1).
10. Press the **TEST** button and count the number of Red LED flashes to verify the correct lighting control setting (Refer to Section 7.2).

## 4.0 LIGHTING CONTROL OPTIONS

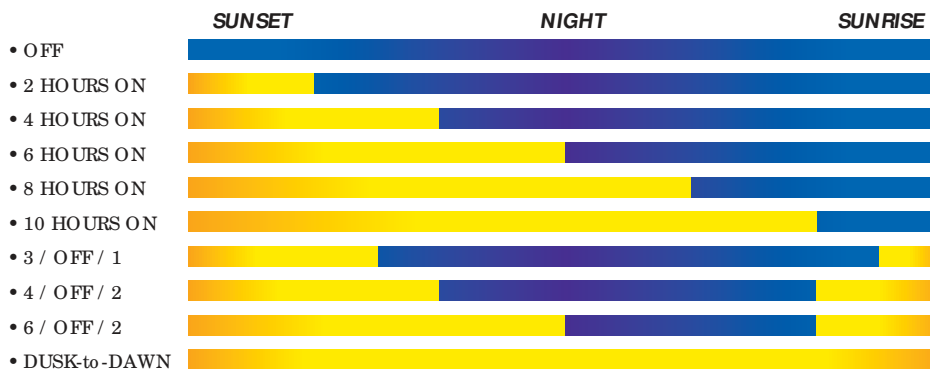

## **5.0 LED INDICATORS**

---

### **GREEN LED:**

The green LED indicator will light whenever sunlight is available for battery charging. The green LED will turn off at night.

Because the SunLight uses a PWM constant voltage charging process, there is usually some amount of energy going into the battery at all times. Although the charging current falls to very low levels when the battery reaches full charge, the green LED will continue to stay ON all day. This is to indicate that the controller is working and that energy is available from the PV array for charging.

### **RED LED:**

The red LED is an indicator for 3 different functions:

- Automatic low voltage load disconnect (LVD)  
If the battery charge state falls below the LVD setpoint, the light will be disconnected and the red LED will light. This indicates the controller has disconnected the load to protect the battery from further discharge and possible damage. The red LED will turn off when the battery recovers to about 50% of its rated capacity and the load is automatically reconnected.
- Initial controller start-up  
When the SunLight is properly connected to the battery, the red LED will flash 3 times.
- Confirm lighting control selection  
When the TEST button is pressed, the red LED will confirm the lighting control option selected by the rotary switch (Refer to Section 7.2).

## **6.0 INSTALLATION INSTRUCTIONS**

---

### **6.1 RATINGS AND LIMITS**

- The SunLight is rated for 12 volt (or 24 volt) PV systems. Do not connect to a PV array with open circuit voltage ( $V_{oc}$ ) greater than 30 volts (or 50 volts).
- Maximum array short circuit current rating is 12.5 amps and 25 amps.

- Because the SunLight is a series controller, the PV current rating is specified at the PV array's peak power ( $I_{pp}$ ). The SunLight does NOT short the PV array for regulation, and it is not necessary to derate the controller for short-circuit current ( $I_{sc}$ ) as is commonly done with shunt controllers.
- The rated PV input current and the rated load current can both be exceeded by 25% for up to 5 minutes. This 25% overload will reduce the safety margins for surges and will cause heating that can shorten the life of the controller.

For the reasons noted above, these higher overload ratings should **NOT** be used for routine operation. They are only to note overload capability for system design purposes.

- The SunLight is designed to operate continuously in 60°C ambient temperatures. However, do not install the controller near heat generating sources or in direct sun. This could cause the temperature rating to be exceeded and damage the controller.
- The date of manufacture can be found on the serial number (bottom of case). The first 4 digits are the year and week.

## **6.2 POLARITY PROTECTION**

The SunLight is generally protected from reversed connections, but the system operator and other equipment will be at risk when polarities (+ and -) are reversed. Carefully check before making each connection to be certain the polarity is correct.

## **6.3 BROWNOUT PROTECTION**

If battery voltage sags below 8 volts for any reason (such as pressing TEST in LVD with a weak battery), the microcontroller may reset. This is to prevent a low voltage condition from causing the microcontroller to lock-up at an unattended site.

Note that a brownout reset will begin a new start-up sequence for measuring night length (Refer to Section 7.4).

## **6.4 INSTALLATION PROCEDURE**

### **NOTES:**

- The SunLight prevents reverse current leakage at night, so a blocking diode is not required in the system.
- The connector terminals will accept a maximum wire size of AWG #10 (up to 5.2 mm<sup>2</sup>). A flathead screwdriver is required. (Some #10 spade connectors may not fit in this terminal.)

- Tighten each terminal clamping screw to 20 inch-pounds of torque.
- The SunLight is designed to regulate power from a PV array. Other generators can be connected directly to the battery, however, with no effect on the SunLight.
- Do not connect any system wires (Solar, Battery, Light) to the **SEALED OR FLOODED SELECT** terminal.

Refer to the connection diagram on page 3 to illustrate each of the following installation steps.

1. Inspect the controller for shipping damage. If possible, mount the SunLight to a vertical surface.

Allow a minimum of 5 cm (2 inches) space above and below the controller for air flow. Protect the controller from direct sunlight or other heat sources.

The SunLight can be mounted outdoors. Avoid mounting in direct rain such that water could collect under the cover. If installed in an enclosure, some ventilation is recommended to minimize operating temperatures.

**NOTE:** *The SunLight is very corrosion resistant. The case is hard coat anodized, cover screws are stainless steel, the circuit is encapsulated, and the terminals are copper and nickel plated brass.*

2. Confirm that the Solar array and loads will not exceed the current ratings of the Sunlight controller being installed.

**NOTE:** *A SunSaver can be connected in parallel with a SunLight for additional amps of solar charging. Make sure each controller's input rating is not exceeded. The lighting load can only be connected to the SunLight and cannot exceed the load rating.*

3. **CONNECTION ORDER** The label has each system connection numbered from 1 to 6. This is the recommended order of system connections. The **BATTERY** must be connected before the **SOLAR** to properly start the microcontroller.
4. **BATTERY** Connect the 12-volt (or 24V) system battery. The green LED will not light. If the red LED (LOAD DISCONNECT) lights and stays lit, the battery charge state is low and should be recharged before completing the installation.



**NOTE:** *If the battery voltage is below 11.7 (or 23.4) volts, the load has been automatically disconnected due to a very low battery charge condition, and the battery must be recharged.*

**NOTE:** *A battery below 10 volts may not start the microcontroller properly. Make sure the battery is charged before installing the system.*

5. **SOLAR** First, be certain the battery (+ and –) is connected correctly. Then connect the solar array to the **SOLAR** terminals. (Be **CERTAIN** that the PV + and – wires are connected correctly). The green LED will light if the array is connected during the daytime and the array is wired correctly.

**NOTE:** *If the SOLAR is disconnected during installation, the controller will see this as the first night and the length of night will be too short. This will only affect ON/OFF/ON settings, and will automatically be corrected over 4 days. If the PV array is disconnected, it is best to disconnect the battery and restart the microcontroller before leaving the site.*

**CAUTION:** *Remember that the Solar array will generate power whenever in sunlight. Also, be careful not to short-circuit the PV array while connected to the controller, since this will damage the controller.*

6. **LIGHT** Connect the light to the **LIGHT** terminals. Turn the light on with the **TEST** button (Refer to Section 7.2).

If the load causes the red LED to turn on soon after the light was activated, the battery must be recharged.

7. **SEALED OR FLOODED SELECT** The SunLight is shipped with a jumper installed between the **LIGHT**-negative terminal (connection 5) and the **SEALED OR FLOODED SELECT** terminal. With this jumper installed, the SunLight is configured for charging **SEALED** batteries.

If your PV system has a **FLOODED** battery, simply remove the jumper to change the SunLight to a flooded battery charger.

The SunLight can be changed between **SEALED** and **FLOODED** as many times as you wish by using the jumper. Save the jumper for future use in case your battery type is changed. If the jumper is lost, a wire can also be used.

8. For safety and the most effective lightning protection, the negative conductor of the battery should be properly grounded. The SunLight connects the PV-negative, Battery-negative and Load-negative internally per UL recommendations. No switching is done in the negative current path.

---

## **7.0 OPERATION**

---

### **7.1 SELECT LIGHTING CONTROL OPTION**

After completing the system connections, select the desired LIGHTING CONTROL option. Refer to Section 4.0 for a summary of the SunLight's ten standard options for lighting control. A brief description follows below:

OFF	Lights remain turned off
2,4,6,8,10	Hours light is turned on after sundown
3/1, 4/2, 6/2	Light is turned on after sundown, turned off during the night, and turned on again one hour (3/1) or two hours (4/2, 6/2) before sunrise
D/D	Dusk-to-Dawn, light is on all night

To select a lighting option, turn the rotary digital switch to the desired position. An arrow in the rotary switch will point to the selected position. This is a digital switch, so it will click into each of the ten positions.

To confirm correct selection of the desired control option, press the TEST button located below the rotary switch (see Section 7.2 below).

### **7.2 TEST BUTTON**

Press the TEST button until a distinct click is heard and felt.

This button performs two functions:

- a. Confirm rotary switch selection  
To verify that the rotary digital switch is set at the desired position, press the TEST button. The red LED will flash once per second. Count these LED flashes to confirm the correct switch setting.  
Each of the 10 LIGHTING CONTROL positions has a unique number of flashes. These are as follows:

Switch Setting	# of Flashes	Switch Setting	# of Flashes
OFF	0	10	5
2	1	3/1	6
4	2	4/2	7
6	3	6/2	8
8	4	D/D	9

**NOTE:** Rotate the rotary switch one full cycle if there is an incorrect or no LED flash (except for OFF setting).

- b. Turn system lights on  
 Pressing the TEST button will turn the system lights on to verify correct installation or for troubleshooting a system problem. The lights will be turned on anytime (day or night) for 5 minute intervals.
- The lights can be turned on repeatedly with the TEST button except when the system is in LVD (load disconnect/red LED on). In LVD the TEST button will only work 3 times to avoid damaging the battery.
- If pressing the TEST button causes a load disconnect (LVD), the lights will turn off. Wait 5 minutes and press TEST again to turn the lights on in LVD.

### 7.3 OPERATOR TASKS

The SunLight is a fully automatic solar lighting controller that includes electronic functions to protect both the controller and the PV system. The controller is designed to operate for long intervals at remote, unattended sites.

The only manual tasks performed by the operator are:

- a. Installation (see Section 6.4)
- b. Select lighting control option (see Section 7.1)
- c. Maintenance (see Section 7.5)

### 7.4 OPERATION AND FUNCTIONS

The PV system operator should become familiar with the following operating functions and design of the SunLight controller. Refer to the Specification Summary for actual setpoints and other parameter values.

- **100% Solid State**  
 All power switching is done with FETs. No mechanical relays are used in the controller.

- **Battery Charge Regulation**

SunLight uses an advanced series PWM charge control for constant voltage battery charging. A true 0 to 100% PWM duty cycle is very fast and stable for positive charge control under all system conditions.

- **Day-Night Transition**

The SunLight uses the solar array to detect day and night. The transition to night requires a solar insolation level less than 2 percent. The transition back to day requires a high solar array open-circuit voltage. Both state changes require 10 minutes of continuous transition values before making the change. These constraints avoid false transitions due to lightning or dark storm clouds.

- **Measure Night Length**

The LIGHTING CONTROL options that turn the lights on again before sunrise require that the SunLight measure the length of the night. Therefore, the controller cannot turn the lights on before sunrise the first night after installation (or after reconnecting the battery). If the solar array is disconnected during service, the controller will then measure a faulty night length. Either reset the controller by reconnecting the battery, or this short “night” will be automatically corrected by the controller after 4 days of service.

**NOTE:** *The SunLight uses the open circuit voltage of the PV panel to determine the correct time for dawn and dusk. If the PV panel is covered with debris (e.g. snow, leaves, dirt), the PV panel voltage may be too low which can cause load timing errors.*

*If the load is operating erratically, make sure the PV panels are clean, there are no obstructions shading the array, and the PV panels are oriented to the sun correctly. The SunLight will automatically correct load timing errors within 4 days of clearing the array.*

- **Temperature Compensation**

A sensor next to the green LED measures ambient temperature conditions. The SunLight corrects the constant voltage setpoint  $-27$  (or  $-54$ ) mV per  $^{\circ}\text{C}$  with a  $25^{\circ}\text{C}$  reference. This correction matches the battery charging to the changing electrochemical properties of the battery, and works best if the battery and controller are in a similar thermal environment.

- **Sealed / Flooded Select**  
Flooded batteries require more vigorous charging to avoid stratification, and sealed batteries require precise control to avoid outgassing. The SunLight constant voltage setpoints are 14.4 volts for flooded batteries, and 14.1 volts for 12 volt sealed batteries. See Section 6.4-7 for more information.
- **LED Indicators**  
See Section 5.0
- **Low Voltage Disconnect (LVD)**  
If the battery falls below 11.7 (or 23.4) volts, the load is disconnected from the battery to protect against harmful deep discharges. A one minute delay prevents load disconnects from transients. The load is automatically reconnected when the battery voltage recovers to 12.8 (or 25.6) volts.
- **Battery Disconnect**  
If the battery is disconnected during the daytime, the PV array will continue to provide power to the controller. The SunLight will immediately go into PWM and provide power at a constant voltage to the load. This will continue as long as sufficient power is available from the PV array.
- **Parallel Controllers**  
Morningstar controllers work very well in parallel configurations. No blocking diodes are required. The only constraint is that each controller must have an independent and separate PV subarray and load. Make sure that each controller's rating for PV and load current is not exceeded.
- **Auxiliary Generators**  
Engine generators and other sources of power may be connected directly to the battery for charging. It is not necessary to disconnect the SunLight from the battery. However, do not use the SunLight to regulate these other generators.
- **Reverse Current**  
The SunLight prevents the battery from discharging through the PV array at night. There is no need to install a blocking diode for this purpose.

## **7.5 INSPECTION AND MAINTENANCE**

The following inspections and maintenance tasks are recommended at least once per year for best controller performance.

1. Confirm that the correct battery type has been selected (sealed or flooded with the jumper).
2. Confirm that the current levels of the Solar array and load do not exceed the SunLight ratings.
3. Tighten all the terminals. Inspect for loose, broken, or burnt wire connections. Be certain no loose strands of wire are touching other terminals.
4. Press the TEST button to verify the lights are working.
5. Check that the controller is securely mounted in a clean environment. Inspect for dirt, insects, and corrosion.
6. Check that air flow around the controller is not blocked.
7. Protect from direct sun and rain. Confirm that water is not collecting under the cover.
8. Check that the controller functions and LED indicators are correct for the system conditions at that time.
9. Make sure the PV array is clean and clear of debris and snow. Confirm the array is oriented correctly for the installation location.

---

## **8.0 TESTING AND TROUBLESHOOTING**

---

### **8.1 TESTING WITH A POWER SUPPLY**

Normal SunLight operation can be tested with a power supply used in place of either the PV array input or the battery. To be certain the SunLight will not be damaged, observe the following cautions:

- Current limit the power supply to no more than one half the SunLight rating.
- Set the power supply voltage to 15 volts DC or less for 12V systems, and 30 volts DC or less for 24V systems.
- Connect only one power supply to the controller.

**NOTE:** For more information on testing SunLight controllers with a power supply, contact the Morningstar Website for test procedures.

## 8.2 TROUBLESHOOTING

The SunLight is very rugged and designed for the most extreme operating conditions. Most PV system problems will be caused by connections, voltage drops, and loads.

Troubleshooting the SunLight controller is simple. Some basic troubleshooting procedures are listed below.

- CAUTIONS:**
- 1. Troubleshooting should be done by qualified personnel only.*
  - 2. Remember that a battery can cause serious damage if shorted.*
  - 3. There are no user serviceable parts, fuses or circuit breakers inside the SunLight.*
  - 4. Observe all normal precautions when working with energized circuitry.*

### 1. BATTERY IS NOT CHARGING

- Check the green LED indicator. The green **CHARGING** LED should be on if it is daytime.
- Check that the proper battery type (sealed or flooded) has been selected.
- Check that all wire connections in the system are correct and tight. Check the polarity (+ and -) of the connections.
- Measure the PV array open-circuit voltage and confirm it is within normal limits. If the voltage is low or zero, check the connections at the PV array itself. Disconnect the PV from the controller when working on the PV array.
- Check that the load is not drawing more energy than the PV array can provide.
- Check if there are excessive voltage drops between the controller and the battery. This will cause undercharging of the battery.
- Check the condition of the battery. Determine if the battery voltage declines at night with no load. If unable to maintain its voltage, the battery may be failing.
- Measure the PV voltage and the battery voltage at the SunLight terminals. If the voltage at the terminals is the same (within a few tenths of volts) the PV array is charging the battery. If the PV voltage is close to the open circuit voltage of the panels and the battery voltage is low, the controller is not charging the batteries and may be damaged.

## 2. **BATTERY VOLTAGE IS TOO HIGH**

- a. First check the operating conditions to confirm that the voltage is higher than specifications. Consider the temperature compensation of the controller's PWM setpoint. For example, at 0°C the controller will regulate at about 15.1 volts (for 12 volt flooded batteries).
- b. Check that the proper battery type (sealed or flooded) has been selected.
- c. Check that all wire connections in the system are correct and tight.
- d. Disconnect the PV array and momentarily disconnect the lead from the **BATTERY** positive terminal. Reconnect the battery terminal and leave the PV array disconnected. The Green charging light should not be lit. Measure the voltage at the **SOLAR** terminals (with the array still disconnected). If the Green charging light is on or battery voltage is measured at the **SOLAR** terminals, the controller may be damaged.

## 3. **LOAD NOT OPERATING PROPERLY**

- a. Press the TEST button to turn the lights on. This will assist in troubleshooting the problem.
- b. Check that the load is turned on. Check that no system fuses are defective. Check that no system circuit breakers are tripped. Remember that there are no fuses or circuit breakers inside the SunLight.
- c. Check connections to the load, and other controller and battery connections. Make sure voltage drops in the system wires are not too high.
- d. Check for proper LED indications on the SunLight. If the red **LOAD DISCONNECT** LED is on, the load has been disconnected due to low battery voltage. This is generally a normal state when the load exceeds the PV array output due to weather and other sunlight conditions.
- e. Check the PV array voltage under direct sun, with the array leads disconnected. The voltage should be close to the expected open circuit voltage for the panel type used.
- f. Visually inspect the PV array and verify that the array is clear of debris (e.g. leaves, snow, dirt) and that it is oriented correctly for the installation location (See NOTE pg. 10).
- g. Measure the voltage at the controller **BATTERY** terminals. If this voltage is above the LVD, the load should have power. Press the test button and then measure the voltage at the controller **LOAD** terminals, and if there is no voltage present, the controller may be defective.

