

Sunburst Eclipse Awning User / Operating Instructions

A. ROLLOUT PROCEDURE - ALL TERRAIN POSITION

Step 1.

Unlock both arms from travel position. To open travel locks squeeze rafter and top support arm together and move plastic slider on back of top support arm upwards as far as possible (See Figure 1).

NOTE: Pull rod may be used to move slider in this step.

Figure 1

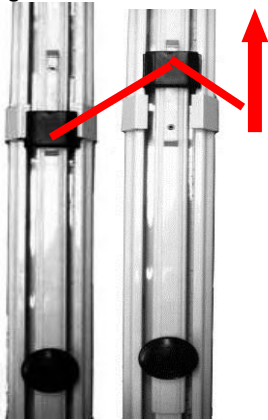

Step 2.

Loosen black rafter knobs located on back of BOTH rafters.

Step 3.

Locate Ratchet Lever behind right end of roller. Using pull down rod move lever downward (See Figure 2). (The Ratchet mechanism is functioning correctly if a clicking noise is heard when rolling the awning out or in.)

Figure 2



Step 4.

Insert pull rod through loop in pull strap and pull awning open until fully extended (See Figure 3). **Do not overextend roller.**

****NB. See step B 6 overleaf.**

Figure 3



Step 5.

Slide the rafter up support arm until it locks into position over the black spring button. Tighten knob on rafter to tension fabric (See Figure 4 & 5). Repeat other arm.

Figure 4



Figure 5



Step 6.

- To raise awning:
- a) Swing trigger handle on Side of arm upward.
 - b) Lift handle slightly and pull and hold trigger with index finger.
 - c) Using handle lift awning Half way out. Release trigger and let arm slide down slowly until trigger locks.
 - d) Repeat other arm lifting awning all the way out.
 - e) Go back to the first arm and lift all the way out.

Figure 6

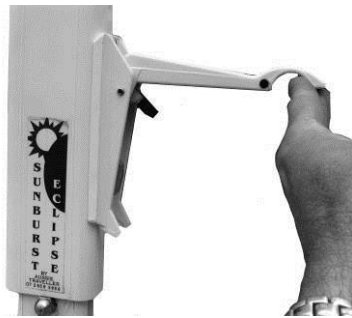

NOTE: In light rain conditions, lower one arm 2' - 4' to allow water to drain from fabric to avoid water pooling.

Step 7.

Pull strap may be removed and stored by sliding it off roller end cap.

RECOMMENDATION: The All Terrain position (support arms remain attached to R.V.) is stronger and more stable than Patio position and should be preferred when using the awning.

B. TO MOVE FRAMESET LEGS FROM ALL TERRAIN POSITION TO PATIO POSITION

NOT RECOMMENDED:

NOTE: FOR POP TOP CARAVANS - Because the awning rafter arm fits to the shoulder of the pop top caravan and not level with the fabric on the pop top, moving the arm from the All Terrain position to Patio position and back to All Terrain position must be executed correctly. If not executed correctly the action has the potential to damage both the ratchet mechanism and the top frameset mounting bracket on the pop-top shoulder.

Figure 7



Step 1.

Set up awning according to instructions for Rollout Procedure A.

Step 2.

Ensure rafter knobs shown in Figure 5 are very tight.

IMPORTANT: With awning roller parallel to ground move ratchet lever to down (roll out) position.

Step 3.

Depress latch on bottom bracket. Using lift handle swing arm away from R.V. until set in vertical position. (Do not pull trigger during this step.)

Step 4.

Adjust roller to desired height using trigger handle and trigger.

Step 5.

Secure bottom foot to ground by driving stakes (not provided) in crisscross manner (See Figure 8). Repeat other arm. Take care not to break foot casting.

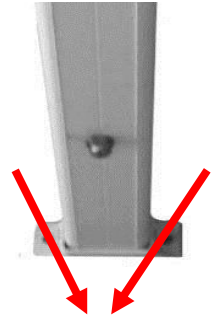

Further help to firmly hold the awning to the ground can be added by using a rope secured around the roller and pegged to the ground.

Step 6.

When erected ensure the roller pull strap sail track is positioned at 9 o'clock (left end) as per drawing below. This will allow rain water to run off the fabric.

Reposition the roller as follows:

Loosen black rafter knobs. Pull down and away from the vehicle to release pressure from the ratchet and move ratchet lever to the up position. Release the pressure on the pull strap and allow the roller to roll up until just past the 9 o'clock position. Again, pull down and away on the pull strap. Check that the 9 o'clock position has been attained. If not repeat above process. This then locks the roller against the ratchet. Continue to pull down on the strap/bottom leg (see all terrain position) to maintain fabric tightness and tighten black rafter knob. Move to other end of awning, pull down on pull strap/bottom leg and lock up black rafter knob.

Note: By leaving the ratchet in the roll in position the awning will not be able to roll out under wind pressure, but it relying only on the black rafter knobs to stop it rolling in. To assist the black rafter knobs and to give added strength against wind flap and water pooling the addition of an Anti Flap Kit and Curved Roof Rafters is recommended.

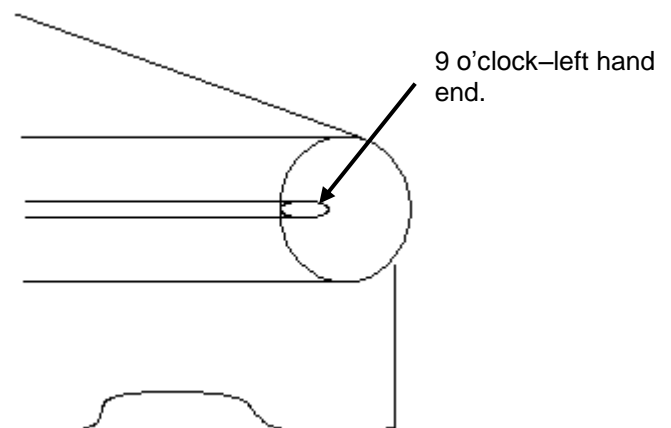

C. TO MOVE FRAMESET LEGS FROM PATIO POSITION TO ALL TERRAIN POSITION

Step 1.

Pull stakes from bottom foot. Release ropes.

Step 2.

IMPORTANT: Commencing with the rear arm (with ratchet mechanism) loosen the knurl knob on the rafter. (Ensure the ratchet lever is in the down (roll out position) position).

Step 3.

Use lift handle (do not pull trigger) to swing arm back to bottom bracket. Push support arm firmly into bottom bracket until latch automatically secures foot on bottom support arm (See Figure 9).

Figure 9

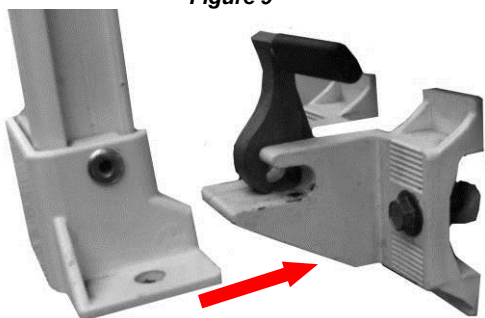

Step 4.

Repeat procedure on other end of awning.

D. ROLL UP PROCEDURE - ALL TERRAIN POSITION FOR ALL R.V.s

Step 1.

Lower both right and left support arms to the dome nut position using the lift handle and trigger.

Step 2.

Loosen knob on rafter. Lower rafter by depressing round black spring button and moving slider downward. Thumb should be positioned over the end of the roller drive casting when depressing the black button to ensure the slider moves under and away from thumb to avoid pinching. Slide rafter to bottom of support arm. Repeat other rafter.

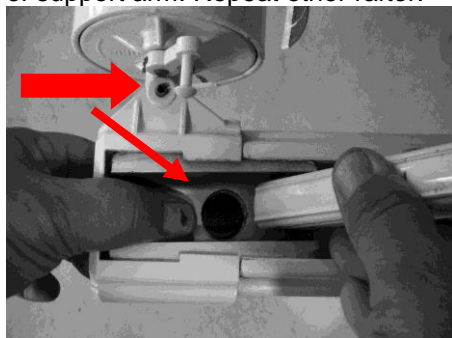

Step 3.

- a) Slide pull strap to the right until ratchet lever is within reach.
- b) Grasp pull strap, and by pulling out, release the pressure on the ratchet lever. Locate ratchet lever behind roller and rotate lever upwards and forward towards the front of the awning (See Figure 10).

Figure 10



NOTE:

If ratchet lever is difficult to operate, use pull strap to rotate roller slightly as if to slacken fabric further. This reduces tension on mechanism and lever.

WARNING: To avoid damage to awning or R.V. DO NOT release ratchet lever without holding pull strap. The awning is under tension and will snap back against the vehicle.

Step 4.

Slide pull strap to centre of awning. Use pull strap to control speed of awning when rolling back towards R.V.

NOTE: To avoid creating a bulge in awning fabric allow strap to roll up diagonally across roller and fabric.

Step 5.

- a) Lock both support arms in travel position. To lock squeeze rafter and top support arm together and move plastic slider downward as far as possible.
- b) Tighten black knobs (See Figure 11), (Opposite of Step 1 & 2 of Rollout Procedure).
- c) Ensure roller does not move when pull strap is given a slight tug. This confirms the ratchet mechanism is working correctly.

Figure 11

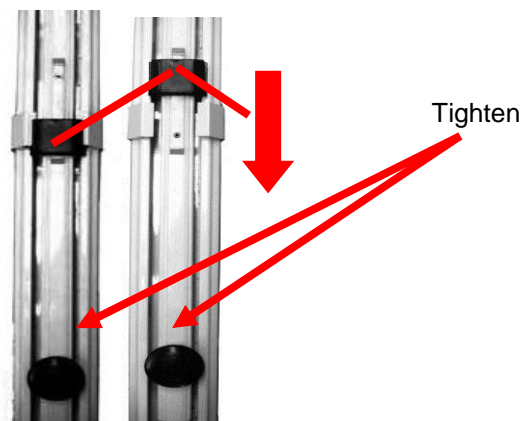

IMPORTANT NOTES

1. To avoid excessive force being exerted on ratchet mechanism do not remove support arm from bottom bracket until ratchet lever has been placed in down (roll out) position. Refer to label on support arm. Return ratchet lever to travel position when arm is replaced.
2. If the ratchet mechanism is subjected to excessive force the ratchet lever may become over tensioned and difficult to operate. To relieve the tension:
 - a) In roll up position: release right support arm from bottom bracket. Swing arm away from R.V. slightly until ratchet lever can be moved to open (roll out) position. Return support arm to bottom bracket.
 - b) In rolled out position: rotate roller slightly, as if to slacken fabric. Reverse ratchet lever. When releasing lever maintain your grip on pull strap, to prevent awning from snapping back against R.V.
3. CLOSE awning in strong winds or rain.
4. In light rain conditions, lower one arm 2' - 4' to allow water to drain from fabric and avoid water pooling.
5. Damage to awning fabric, hardware and locking mechanism cause by wind or water pooling is NOT covered by warranty. **NEVER** leave awning rolled out when unattended.
6. Damage to awning fabric caused by extreme temperatures is not covered by warranty. (Never use awning in snow or freezing temperatures as fabric may crack or otherwise be adversely affected.)

PERIODIC MAINTENANCE:

- i) Lubricate control handles, lock buttons, locking knobs, support arms and rafter sliders with silicone or similar lubricant to ensure easy operation.
- ii) Check correct setting of adjustable stop bolts.
- iii) Ensure all rivets and lag screws in brackets are tight.

GENERAL TIPS - DO'S

- i) Do keep your awnings clean. This is the best protection against mildew. Even on mildew resistant fabric, mildew can grow on accumulated dirt and eventually damage or stain the fabric.
- ii) Do wash down your awning. You can use a mild soap and water solution brushing lightly with a cloth or soft brush. Rinse thoroughly and allow drying prior to storage. We recommend doing this on a hot, sunny day.
- iii) Do keep the underside of your awning clean by simply brushing with a clean household broom. It may also be washed in the same manner as the top.
- iv) Do lower one arm 2' - 4' in light rain conditions to allow water to drain from the fabric and avoid water pooling.
- v) Accessories such as Aussie Travellers anti flap kit and curved roof rafters will help eliminate wind flap and water pooling.
- vi) When adding walls we recommend Aussie Travellers anti flap kit wall attachment system.

GENERAL TIPS - DO NOT'S

- i) DO NOT operate awning in strong winds or rain.
- ii) DO NOT allow awning to snap closed excessively hard.
- iii) DO NOT remove support arm from bracket until ratchet lever has been placed in up (roll in) position. Refer to previous instructions.
- iv) DO NOT overextend awning when rolling out.
- v) DO NOT fold or roll out in extreme cold temperatures.
- vi) DO NOT get insect spray on the vinyl fabric, as some solutions may cause staining or discolour.
- vii) DO NOT allow water to collect on awnings, causing water pooling.
- viii) DO NOT overlook small rips or tears. Have them repaired or separation will result.
- ix) DO NOT wash your awning with truck wash or a harsh strong solution, or with an abrasive cleaner.
- x) DO NOT BBQ, grill or have campfires underneath the awning.
- xi) DO NOT store awnings when damp, or wet. Mildew may grow on the surface of a damp awning and permanently stain the fabric.
- xii) DO NOT permit leaves, twigs, etc. to remain on your awning.
- xiii) Do not use a high pressure cleaning jet.

Sunburst Eclipse Awning Installation Instructions

READ INSTRUCTIONS BEFORE PROCEEDING WITH INSTALLATION.

Each frameset has a right and left arm which are interchangeable. Each arm consists of a top support arm (Stock Code 80200050002000), bottom support arm (Stock Code 80200050010000), top rafter (Stock Code 80200050014000) and bottom rafter (Stock Code 80200050018000). Refer to exploded parts diagram.

Step 1.

Inspect vehicle for sharp edges on doors, windows and lights that may damage awning fabric. Remove sharp edges or cover them with duct tape.

Step 2.

Determine position of awning on vehicle (Figure 1)

- Locate, vehicle floor line to ensure Tek-screws used to attach bottom mounting brackets are securely installed in centre of steel chassis.
- Using a tape measure, determine mounting position of awning on side of R.V. Measure distance between the centre of both support arm roller drive castings (is equal to awning size measured from centre on bracket (Stock Code 80200040010000 right) to centre of bracket (Stock Code 80200040009000 left) (See Figure 1). Make certain position of arms at awning rail and floor line allows proper clearance from doors, windows, storage compartments and wheel wells.

Figure 1

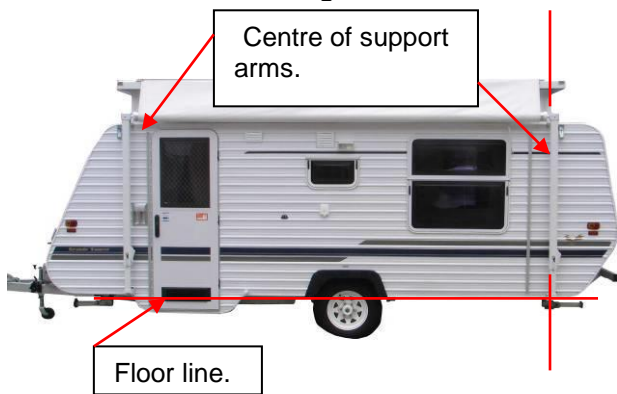

Step 3.

Figure 2

Install door roller (Stock Code 80200070001000) to rise above top outside corner of door. Predrill with 3/32" drill bit and install with #6 x 1/2" screws or pop rivets. (See Figure 2)



Step 4.

Prepare awning rail. Open end of rail and file sharp edges that may damage fabric.

Step 5.

Remove roller/fabric assembly from shipping tube - taking care to completely remove staples from the shipping tube prior to removing the awning. Do not drag or scrape.

Note: To prevent damage to fabric, keep roller/fabric assembly off floor by placing roller across two saw horses.

Step 6.

Figure 3

- Locate and mark position of bottom mounting brackets.
- If using tek-screws supplied drill 2 x 5mm holes for each bracket.
- Attach bottom-mounting bracket to vehicle, sealing holes in vehicle with an appropriate sealant.
- In some cases it may be appropriate to reinforce outside/inside of RV wall when attaching bottom mounting bracket.



100mm X 6mm aluminium reinforcing plate.



Step 7a. Standard Fittings

- a) Locate and mark positions of top mounting brackets.
- b) If using tek-screws supplied drill 2 x 5mm holes for each bracket.
- c) Attach top mounting bracket to vehicle, seal screws with appropriate sealant.
- d) In some cases it may be appropriate to reinforce outside/inside of RV wall or utilise spacer tubes when attaching top mounting bracket. Each vehicle should be assessed on its merits by the installer. **Figure 4**



Step 7b. PopTop Caravan Fittings

Installing top mounting brackets to suit pop-top caravans.

- a) Locate and mark position of pop top mounting brackets (Stock Code 80200050022000)
- b) Locate and mark the caravan frame on the bracket to ensure a strong mounting. (Top and front of bracket See Figure 5)
- c) Drill 2 x 4mm holes through the top of the bracket and counter sink. Drill 2 x 1/8" holes into the caravan frame and fit 3 x 8 gauge x 1" counter sunk screws (supplied). (See Figure 5)
- d) Drill 2 x 4mm holes into the front of the bracket (See Figure 5). Drill 2 x 1/8" holes to the caravan frame and fit 2 x 8 gauge x 1" dome head screws (supplied).
- e) Seal around the edges of the bracket with an appropriate sealant. **Figure 5**

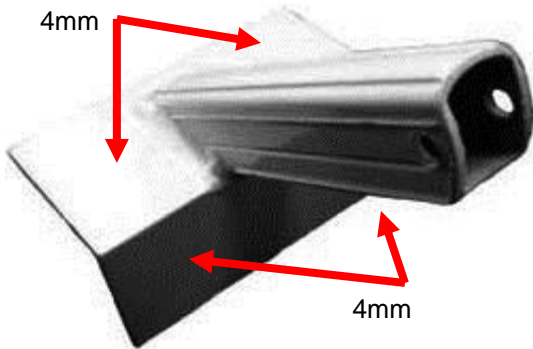

Step 8.

Installation of Sail Track

- a) Using appropriate fasteners ie rivets or screws fix the sailtrack to the vehicle, ensuring that the awning can be slipped into the track.
- b) Seal the top of the track to the vehicle ensuring no water will leak down under the track.

Step 9.

Awning to be mounted when frameset is closed against the vehicle. (See Step 11)
Pretensioning of Roller Springs.

- a) Always follow the directional arrows in either end of roller.
- b) Right Hand Side. Engage the ratchet lever in the down/roll out position and tension the roller as indicated by chart below. (The ratchet will retain the spring tension.)
- c) Left Hand Side. Place a screwdriver through the hole in the roller drive casting and tension the left spring as indicated by the chart below. Secure with pin through hole in casting/spring axle to retain spring tension.

6' - 10' Awning	7 Rotations
10' - 13' Awning	8 Rotations
13' to 15' Awning	9 Rotations
15' to 24' Awning	10 Rotations

Additional tension is added to the roller springs when awning is rolled out.

Step 10.

Installing Fabric to Sail track.

Leaving the fabric rolled up, one-person threads fabric into sailtrack, the second holds the roller.

Step 11.

- a) Slide roller drive casting onto top of arm assemblies (Figure 6B). Do not remove red spacer on roller drive casting (Figure 6A) until Step 14 is complete.
- b) Insert screw through front of roller drive casting and tighten (Figure 6B).

Figure 6A

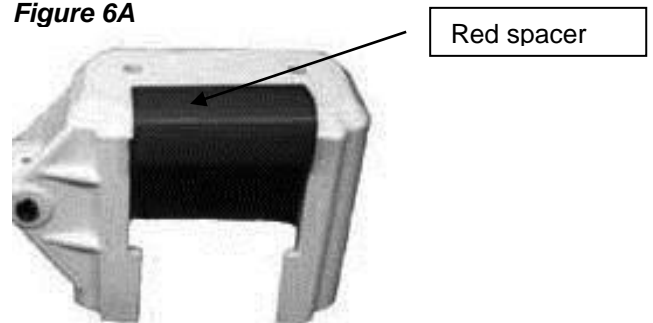
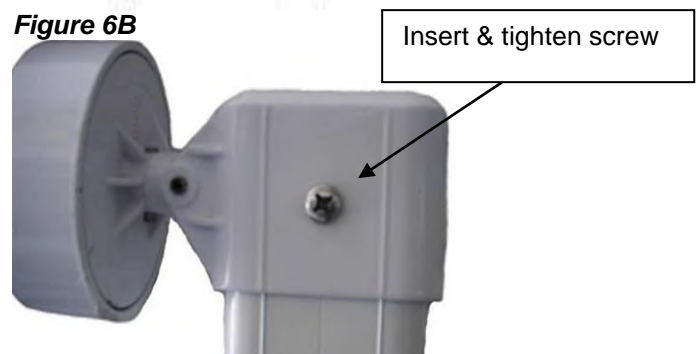

Figure 6B



Step 12.

Installation of Stop Bolt

- Ensure travel lock is in 'lock position' (See Figure 7a) and level travel lock and bracket at top.
- Ensure that the bottom support arm will rest on the stop bolt. Mark position and drill 4mm pilot hole, drill a 10mm hole in arm.
- Fit stop bolt and acorn nut (See Figure 7b).

Figure 7A



Figure 7B



Step 13.

Setting the Awning

- Remove pin (as fitted during step C9) from hole in left-hand casting/spring axle.
- Roll out the awning several times to locate arms and fabric on vehicle with pull strap at comfortable arms length to the centre of the roller.
- Close the awning ensuring that the frameset closes properly, lock the travel lock bracket.
- Drill a 3/32" hole through the sailtrack into fabric spline (Not through the fabric). Install 2 x 6g x 1/4" screw supplied.

Step 14.

Test Awning

- Roll fabric out and retract to ensure that the frameset opens and closes smoothly.
- Remove red plastic spacer from the roller drive casting and discard. Note: Remove only after installation of frameset is complete.

Sunburst Eclipse Awning Parts Stock Codes

STOCK CODE	DESCRIPTION	STOCK CODE	DESCRIPTION
80200040001000	Left Roller Drive Assembly	80200050008000	Plastic Rafter Button
80200040002000	Right Roller Drive Assembly	80200050009000	Plastic Button Spring
80200040003000	Left Roller End Assembly	80200050010000	Bottom Support Arm
80200040004000	Right Roller End Assembly	80200050011000	Foot Casting
80200040005000	Right Outer Casting	80200050012000	Bottom Mounting Bracket
80200040006000	Ratchet Dog	80200050013000	Top Mounting Bracket
80200040007000	Ratchet Lever	80200050014000	Top Rafter
80200040008000	Right Inner Casting	80200050015000	Rafter Bumper Guide
80200040009000	Left Roller Drive Casting	80200050016000	Knurled Knob w/T-nut
80200040010000	Right Roller Drive Casting	80200050017000	Semi-tubular Rivet
80200050001000	Trigger Handle Assembly	80200050018000	Bottom/Inner Rafter
80200050002000	Top Support Arm	80200050019000	Slider
80200050003000	Travel Lock Bracket (set of 4)	80200050020000	Stop Bolt
80200050004000	Slider Stopper	80200050021000	Travel Lock Slider
80200050005000	Slider Lock Screw	80200050022000	Pop Top Mounting Bracket
80200050006000	Rafter Lock Assembly	80200060001000	Pull Strap
80200050007000	Rafter Button Retainer	80200060002000	Pull Down Rod
80200070001000	Door Roller		

TROUBLE SHOOTING

SYMPTOM	POSSIBLE CAUSE	SOLUTION
1. Fabric ripples or does not roll up evenly.	Fabric not aligned properly.	Pull fabric right or left at sailtrack and secure with screws.
2. Arms bind - not releasing evenly or not nesting properly when rolled up.	Top mounting bracket out of alignment.	a) Realign top mounting bracket until rafter is centred in top support arm (Stock Code 80200050013000). b) Lubricate rafter bumper guide (Stock Code 80200050015000). c) Ensure fabric is rolling up evenly.
3. Unable or difficult to release Ratchet mechanism to roll up awning.	Awning may be over extended.	Reduce spring tension on roller pulling down on pull strap or rotating roller by hand. Lever can now be moved to roll up position. Refer to 'important notes' in operation instructions.
4. Ratchet mechanism jammed in travel position.	Arm has been pulled away from unit without releasing Ratchet lever.	Remove arm from bottom mounting bracket (Stock Code 80200050012000), pull outward until tension is released on ratchet, move ratchet lever to unlocked position. Replace arm in bottom mounting bracket. Roll out awning.
5. Holes in fabric caused by centre rafter. (Not covered by warranty).	Centre rafter top mounting bracket installed to high.	Flex roller downward as if to simulate rough road conditions. Mount bracket accordingly.
6. Awning will not roll up completely.	a) Rafter knobs tight. b) Springs have lost tension.	Loosen knobs. Add turns to roller springs.
7. Roller will not lock when rolling down or at top.	Ratchet lever not fully engaged.	Ensure ratchet lever (Stock Code 80200040007000), has moved fully into position.
8. Foot will not engage easily in bottom mounting bracket.	Bottom mounting bracket not aligned.	Check vertical and horizontal alignment of bottom mounting bracket (Stock Code 80200050012000).

Sunburst Eclipse Awning Exploded Parts

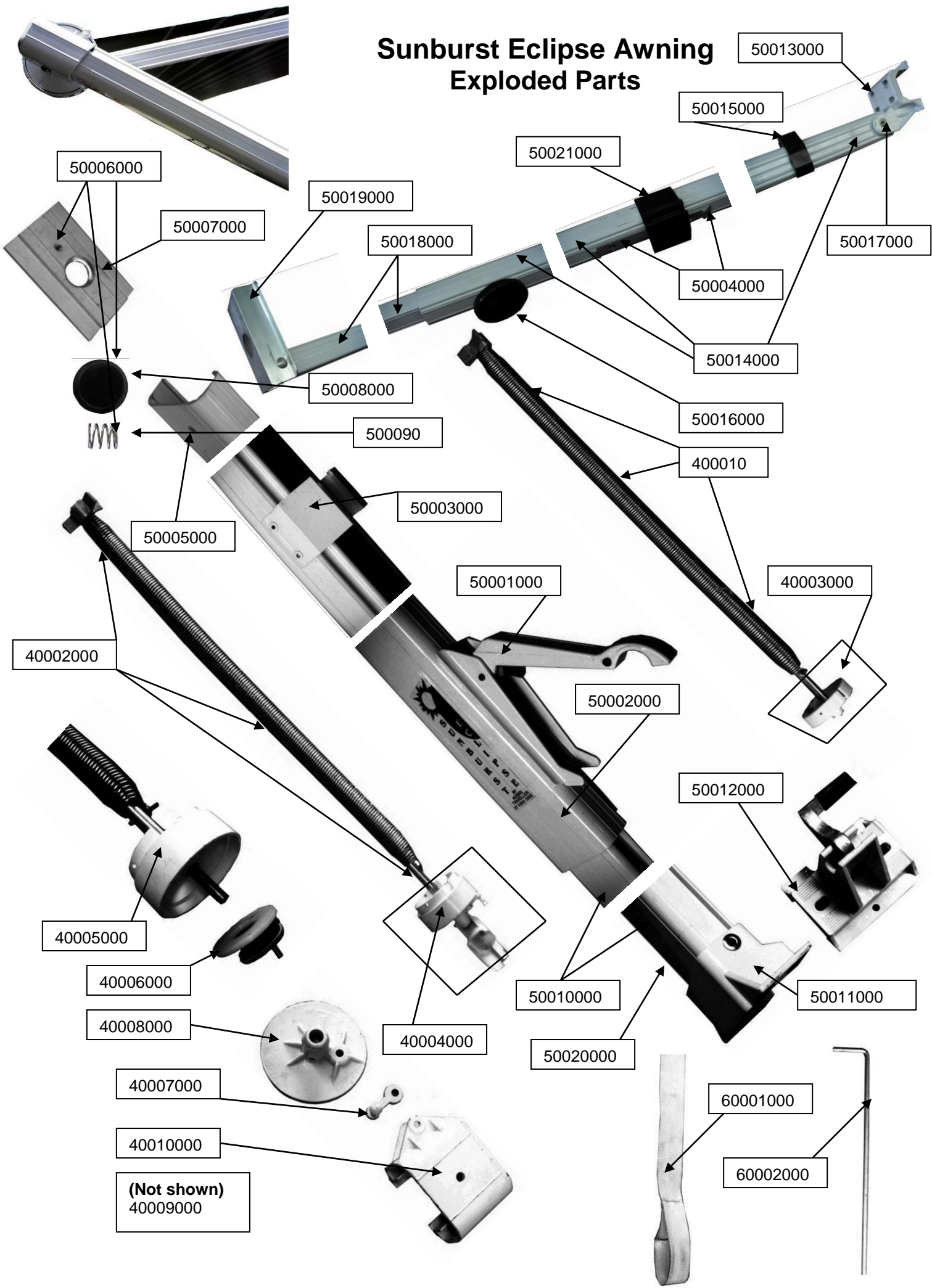

12 MONTH WARRANTY SUNBURST ECLIPSE

AND PROOF OF PURCHASE

CUSTOMER

NAME _____

ADDRESS _____

CITY _____ STATE _____ POSTCODE _____

Yes, my Sunburst Eclipse Awning has been installed by an authorized Aussie Traveller Dealer and the awning is in satisfactory condition. My dealer has also given me full instruction on the use and maintenance of the awning.

Purchaser's Signature _____

DEALER

Name _____

Address _____

City _____ State _____ Postcode _____

Yes, I have installed the purchaser's Sunburst Eclipse Awning and it is in satisfactory condition. I have also given the purchaser instructions on the use and maintenance of the awning.

Dealers Signature _____

Date of Installation _____

Date of Purchase (If Not Installed) _____

Size _____ Colour _____

SERIAL NUMBER

If Applicable

Aussie Traveller Pty Ltd
11-15 Oasis Court
Clontarf, Queensland, Australia
Telephone 07 3284 3284
Facsimile 07 3284 5969

PO Box 126
Clontarf Beach Qld 4019

12 MONTH WARRANTY

- A. Duration:** Aussie Traveller guarantees the awning for a period of 12 months from date of original purchase.
- B. Who receives this warranty?** The original purchaser only, and may not be assigned or transferred to subsequent owners.
- C. This warranty covers: Defects in materials or workmanship as follows:**
- The vinyl fabric is warranted against
 - Holes caused by mildew (Mildew will form on dust and dirt and stain fabric if fabric is not kept clean).
 - Excessive cracking, peeling, hardening or loss of strength while used under normal conditions.
 - Excessive fading (a slight colour change may occur due to ultraviolet rays).
 - All hardware components including roller are warranted not to bend or break if not subjected to high winds, water pooling or accidents.
- D. This warranty does not cover**
- Damage to fabric caused by storm, wind and rain. Stretching of fabric caused by water pooling on fabric.
 - Breakage or bending of hardware due to storm, wind, rain or water pooling on fabric.
 - Labour charges connected with installation of replacement or repaired parts.
 - Implied warranties including those of merchantability and fitness for a specific purpose are limited to 12 month from original purchase date. Liability for indirect or consequential expenses under any and all warranties is excluded. Under no circumstances shall Aussie Traveller be liable for any injury, loss or damage, direct or inconsequential, arising from use of the awning.
 - Any damage or failure due to accident, normal wear and tear, purchaser's neglect, improper maintenance or failure to use product in accordance with operation instructions provided with product.
 - Awnings not installed by an authorized Aussie Traveller dealer. Awnings not installed in accordance with installation instructions provided with product. Damage or failure due to parts left off during installation. Damages (holes, scrapes, abrasions) or failure caused by or during installation.
 - Freight expenses to and from Aussie Traveller in shipping defective and replacement parts.
 - Failure or damage that results from use of Aussie Traveller awnings in connection with any other product not specifically approved in writing by Aussie Traveller.
- E. Responsibilities of Aussie Traveller under this Warranty**
- Repair or replace defective parts at no charge within the first 12 months from original purchase date.
- F. Responsibilities of Purchaser**
- Complete warranty registrations forms and return to Aussie Traveller within 10 days of original purchase or show dated proof of purchase to qualify for any credits due under provisions for coverage.
 - Promptly notify seller or alternately Aussie Traveller of any claims.
 - Obtain a Return Authorisation Number from the seller or Aussie Traveller, and return product or part to an authorised Aussie Traveller distributor. NO returns will be accepted without a Return Authorisation Number.
 - All freight expenses to and from the Aussie Traveller distributor or Aussie Traveller.
 - All labour charges and travel costs connected with installation or replacement parts must be paid by purchaser.
 - In addition to returning defective parts as described above, Aussie Traveller at our discretion only, may ship parts to purchasers on a C.O.D. basis, payable by purchaser at full retail price. Upon determination by Aussie Traveller that the original parts are defective, Aussie Traveller will notify purchaser of such determination, and will issue appropriate credit to purchaser. (This option will minimize the period of time during which purchasers is unable to use original parts.)
 - Use reasonable care in maintenance, operation, use and storage of product in accordance with instruction contained in operation instruction.

Please Detach and Return to Aussie Traveller

Because of the difficulty in establishing the severity of weather, which an awning can stand up, Aussie Traveller does not cover any damage caused by weather. We have designed awnings to retract and be secured within seconds to avoid such circumstances. The purchaser should investigate insurance coverage when damage is caused by weather.

Please retain this portion for future reference

Serial Number: _____ Purchase Date: _____ / _____ / _____

Dealer: _____

