



Owner's Manual

For Australian refrigerator models:

T1274

Thetford Australia
130-132 Freight Drive
Somerton VIC 3062
Australia

Thetford Customer Support
Telephone: +6 3 9358 0700
E-mail: infoaus@thetford.com.au
Website: www.thetford.com.au

Table of Contents

Safety Awareness.....	3
Safety Instructions.....	3
Warranty.....	4
About Your Refrigerator.....	5
Usage.....	5
Storage volume.....	5
Fresh food compartment.....	5
Frozen food compartment.....	5
Door latch for travel.....	5
Interior light.....	5
Crispers.....	6
Door Bins.....	6
Adjustable shelves.....	6
Operation.....	6
Controls.....	6
Shut down.....	7
Refrigerator Care Checklist.....	7
Defrosting.....	8
Cleaning.....	8
Door Sealing.....	9
Troubleshooting.....	9
If refrigerator does not cool correctly in DC mode.....	9
Over heating shut-off device operation.....	10
Low voltage protection system.....	10
Over current protection system.....	10
Refrigerator Maintenance Checklist.....	10
Replacement Parts.....	10
Wiring Pictorial.....	11

Safety Awareness

Read this manual carefully and understand the contents before you use the refrigerator.

Be aware of possible safety hazards when you see the safety alert symbol on the refrigerator and in this manual. A signal word follows the safety alert symbol and identifies the danger of the hazard. Carefully read the descriptions of these signal words to fully know their meanings. They are for your safety.



This signal word means a hazard, which if ignored, can cause dangerous personal injury, death, or much property damage.



This signal word means a hazard, which if ignored, can cause personal injury or much property damage.

Safety Instructions



- The storage of flammable materials behind or around the refrigerator creates a fire hazard. Do not use the area behind the refrigerator to store anything, especially flammable materials (gasoline, cleaning supplies, etc.) This is especially important when converting from a gas absorption refrigerator.
- Do not store any explosive substance, such as aerosol cans with flammable propellant, in this refrigerator.
- A circuit overload can result in an electrical fire if the wires and/or fuses are not the correct size. Use only the wire and fuse sizes as written in the "Installation Manual".
- Never open or damage the refrigerator circuit of the cooling system at the back or the inside of your appliance. The cooling system is pressurised and contains flammable substances.
- Component parts shall be replaced with like components and that servicing shall be done by factory authorized service personnel, so as to minimize the risk of possible ignition due to incorrect parts or improper service.
- Risk of fire or explosion due to flammable refrigerant used. Follow handling instructions carefully in compliance with local regulations.
- Keep Ventilation openings, in the appliance or in the built -in structure, clear of obstruction.
- Do not use mechanical devices or other means to accelerate the defrosting process, other than those recommended by the manufacturer.
- Do not use electrical appliances inside the food storage compartments of the appliance, unless they are of the type recommend by the manufacturer.
- Handling, moving and use of the refrigerator to avoid either damaging the refrigerant tubing, or increasing the risk of a leak.
- Risk of child entrapment. Before you throw away your old refrigerator: Take off the doors and leave the shelves in place so that the children may not easily climb inside.



- Incorrect installation, adjustment, change to, or maintenance of this refrigerator can cause personal injury, property damage, or both. Have service and maintenance work done by your dealer or by an authorized Thetford Service Center.
- Disconnect the DC power source before doing any maintenance work on the refrigerator. All service work on this refrigerator must be done by a qualified service technician.
- Do not bypass or change the refrigerator's electrical components or features.
- Do not spray liquids near electrical outlets, connections, or the refrigerator components. Many liquids are electrically conductive and can cause a shock hazard, electrical shorts, and in some cases fire.
- The rear of the refrigerator has sharp edges and corners. To prevent cuts or abrasions when working on the refrigerator, be careful and wear cut resistant gloves.
- This appliance is not intended for use by persons (including children) with reduced physical, sensory or mental capabilities, or lack of experience or knowledge, unless they have been given supervision or instruction concerning use of the appliance by a person responsible for their safety. Children should be supervised to ensure that they do not play with the appliance.
- Build-up of dust on the condenser will reduce the performance of the appliance and increase the risk of overheating of the cooling system. Have the condenser and cooling fan cleaned by qualified service personnel if you suspect poor performance.

Warranty

Thetford offers the end users of its products a three-year warranty. In the case of malfunction within the warranty period, Thetford will replace or repair the product. In this situation, the costs of replacement, labour costs for the replacement of defective components and/or the costs of the parts themselves will be paid for by Thetford. Purchased spare parts carry a one-year warranty. Any fitting and/or labour costs are not covered by warranty.

1. To submit a claim under this warranty, the user must take the product to an authorised Thetford Service Center. The claim will be assessed there.
2. Components replaced during repair under warranty become the property of Thetford.
3. This warranty does not prejudice current consumer protection laws.
4. This warranty is not valid in the case of products that are used for commercial purposes.
5. Warranty claims falling into one of the following categories will not be honoured:
 - The product has been improperly used or the instructions in the manual have not been followed;
 - The product has not been installed in accordance with the instructions;
 - Modifications have been made to the product;
 - The product has been repaired but not by an authorised Thetford Service Center;
 - The serial number or product code has been tampered with or removed;
 - The product has been damaged by misuse.

About Your Refrigerator

Usage:

This refrigerator is made for use within a recreational vehicle. As such, it is suitable for camping, but do not expose the refrigerator to rain.

Storage Volume:

This refrigerator is made to store fresh and frozen foods and for making ice.

Total capacity T1274 274 litre Calculated according to AS/NZS 62552-3:2018



The refrigerator is made to operate within 10° off level in all directions. Operating it at more than these limits can cause damage to the cooling system, increased noise and poor cooling performance. Make sure the vehicle is level before you operate the refrigerator.

Operation during travel:

While the refrigerator should be level when the vehicle is stopped, performance during travel is not usually affected.

Fresh food compartment:

Start up the refrigerator and let it cool for eight hours before loading with food. If the refrigerator does not start to cool down after about two hours, contact your dealer or an authorized Thetford Service Center.

For the best cooling performance:

- Let air move freely inside the entire fresh food and frozen food compartments.

To decrease the amount of ice that collects on the rear wall of the refrigerator frozen and fresh food.

- Cover all liquids and moist foods.
- Let all hot foods cool before putting them in the refrigerator.
- Do not open the door any longer than necessary.

Frozen food compartment:

The frozen food compartment is made to keep pre-frozen food frozen and not to quickly freeze food. Keep pre-frozen foods in the frozen food compartment.



NOTE: When making ice, put the ice cube tray directly on the bottom of frozen food compartment. Do not put other items on the ice cube tray while the water is freezing. The water freezes more rapidly if the power switch / thermostat is at the coldest temperature setting.

Door latch for travel:

During travel, the door latch prevents the door from opening. When closing each door, push the door toward the refrigerator until you hear a “click” sound. To open each door, pull the handle away from the refrigerator.

Interior light:

The interior light is located on the top of the fresh food compartment.

The interior light comes on when the refrigerator is ON and the door is open.

To replace the bulb:

1. Use tape to hold the light switch down, which removes power from the light circuit.
2. Remove the cover by pulling it toward the front of the refrigerator (See Art02734).
3. Unplug wire harness connector.
4. Install the replacement light.

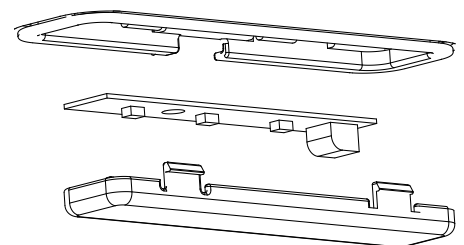

ART 02734

5. Install the cover.

6. Remove the tape from the light switch.

Crisper(s):

The crisper(s) are located at the bottom of the fresh food compartment and supply a storage area to preserve fruit and vegetable freshness. Make sure that you always push the crispers fully in.

NOTICE Do not wash the crispers in a dishwasher. The crispers are not dishwasher safe.

Door bins:

You may put the door bins of the frozen food and fresh food compartment in a location that best meets your needs. To remove the bins, lift them over the locator and pull them away from the door. To install the bins, push them onto the locator.

NOTICE Do not wash the door bins and bin slides in a dishwasher. The door bins and bin slides are not dishwasher safe.

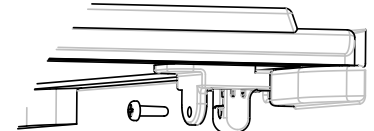

Adjustable shelves:

The shelves in the frozen food and fresh food compartment are made so you can remove them or move them. To remove or move each shelf of the refrigerator: (ART 02733)

- Remove the screw from the retainer of each shelf at the side of the refrigerator.
- Slide the retainer out of the slot (cabinet shelves only)
- Pull each shelf forward out of the slot.
- Push each shelf fully into the slot that you wish.
- Slide the retainer into the slot (cabinet shelves only)
- Attach the retainer with the screw.

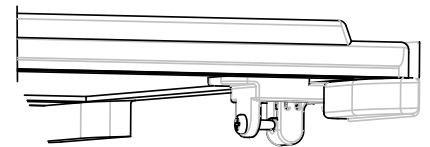

ART 02733

Operation

Controls:

-Touch and release the ON/OFF [1] button to turn the refrigerator on. (ART02735)

- If the indicator light, below the button, glows solid blue, it means the refrigerator is operating correctly.

NOTICE The frozen food compartment and cabinet compartment work independent of each other and both must be adjusted to their desired temperature setting.

- Touch the FROZEN FOOD COMPARTMENT [5] button to set the compartment temperature setting.

-Using the + [4] or – [2] buttons adjust the temperature setting.

- The mode [3] will display the temperature setting
 - 0 is off
 - 1 is the warmest setting
 - 5 is the coldest setting

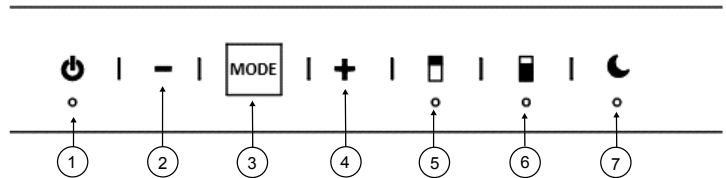

ART 02735

- Touch the CABINET COMPARTMENT [6] button to set the fresh food compartment temperature setting.
 - Using the + [4] or – [2] buttons adjust the temperature setting.
 - The mode [3] will display the temperature setting
 - 0 is off
 - 1 is the warmest setting
 - 5 is the coldest setting
- Press any button to return the control to activate mode, the mode [3] will illuminate. The display will return to standby mode after 5 seconds.
- Touch the NIGHT MODE [7] button to set the refrigerator to night mode. The blue indicator will illuminate.
- Night mode will turn off automatically after eight hours or if you push the night mode button again to turn the blue indicator light off.
- This 8 hour night mode setting can be changed by pressing the night mode button for 3 seconds. After the 3 seconds, the default 8 hours will be shown in the display . To change this setting, press the “+” or “-”, then press night mode button to make the setting go into effect.
- The new setting is archived in the memory until it is changed.

Shut down:

- To shut down the refrigerator, touch and hold the ON/OFF button [1] for 5 seconds and release.
- Once the refrigerator is turned OFF there is a 5 minute wait cycle before the refrigerator can be turned ON. The refrigerator will not turn on again until the 5 minute wait is up.



Do not operate the refrigerator when the ambient temperature is above 43° C. Operation above recommended ambient temperatures can cause permanent damage to the compressor. Operation when the ambient temperature is higher than 43° C. can result in poor cooling performance.

DC Operation Guidelines:

Refer to the Installation Manual for DC Operation requirements and guidelines.

Refrigerator Care Checklist

Your refrigerator will give you years of trouble free service if you do these simple checks every three to six months:

- Keep the fresh food and frozen food compartment clean. See “Cleaning”.
- Defrost the refrigerator as necessary. See “Defrosting”.
- Make sure the door seals correctly. See “Door Sealing”.
- Be aware of any cooling changes that are not because of weather, loading, or thermostat changes. If changes occur, contact your dealer or an authorized Thetford Service Center.
- Make sure the air flow in the lower intake vent, through the refrigerator condenser and coils and out the upper exhaust vent is not blocked or decreased.

Defrosting:

The frozen food compartment walls of the refrigerator operate at below freezing temperature and will naturally form frost from humidity, which is always present in the air. The humidity inside the refrigerator increases:

- with higher outside temperature and humidity.
- with the storage of non-sealed fresh foods or warm foods.
- with the amount of time that the door(s) are open.
- with any air leakage into the refrigerator.

It is normal for frost to collect inside the refrigerator. Excess frost decreases the cooling performance of the refrigerator. Defrost the refrigerator as necessary:

- Remove all food from the refrigerator.
- Turn the refrigerator OFF.

NOTICE

Defrosting the refrigerator makes excess water inside the refrigerator, which falls onto the drip tray and flows to the outside of the refrigerator through the drain tube.

- Put dry towels (etc.) inside the refrigerator to help remove the excess water.



High temperatures can cause the inside surfaces of the refrigerator to warp or melt. Do not use pans of HOT water, a hair dryer, or any other high temperature devices to defrost the refrigerator. Do not use any hard or sharp objects to remove frost. Damage to the interior of the refrigerator can occur.

- To increase the speed of defrosting, put pans of WARM water in the refrigerator.
- Remove the wet towels (etc.) and dry the interior.
- Start up the refrigerator.
- Allow the refrigerator to cool down.
- Return all food to the refrigerator.

Cleaning:

A good time to clean the refrigerator is just after you defrost it.

Clean the inside of the refrigerator as often as necessary to avoid food odours:

- Remove all food from the refrigerator.

NOTICE

Do not use abrasive cleaners, chemicals, or scouring pads because they can damage the interior of the refrigerator.

- Wash the interior with a mild cleaner or a solution of liquid dish detergent and warm water.
- Rinse with a solution of baking soda and clean water.
- Dry with a clean cloth.
- Put all food back into the refrigerator.

Door sealing:

If the door does not seal correctly, excess frost will collect inside the refrigerator. Make sure the door seals correctly:

- Close the door on a piece of paper (See Art00980).
- Gently pull the paper.
 - You should feel a slight drag between the gasket and the cabinet.
 - Do this on all four sides of the door.
 - If you do not feel a slight drag on the paper, the door is not sealing correctly.
 - Have your dealer or an authorized Thetford Service Center correct the seal of the door.

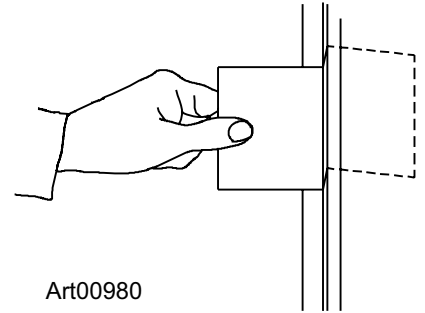

Refrigerator Storage:

Before the refrigerator is stored for an extended (seasonal) period of time:

- Defrost and clean the interior of the refrigerator
- Leave doors open or cracked

Troubleshooting

If the refrigerator does not cool correctly in DC mode:

- Make sure the power switch is not in the OFF position.
- Make sure the compartment control is at the temperature setting that you wish.
- Make sure that the power source to the refrigerator is serviceable.
- Make sure that the fuse or circuit breaker is intact (See "Over current protection system")
- Make sure that the refrigerator is correctly installed and that the built in vents are not blocked.
- Make sure that the ambient temperature is not unusually high (more than 43° C.) (See "Over heating shut-off device operation").
- Make sure that the doors are closed.
- Make sure that the door gaskets are sealing correctly.
- Make sure that the air circulation inside the refrigerator is not decreased by foods or by shelves that are covered with plastic, paper, etc.
- Make sure that hot foods were not placed in the fresh food compartment of the refrigerator.- Make sure that the frozen food compartment is defrosted.

After you make these checks, if the refrigerator does not operate, contact your dealer or an authorized Thetford Service Center.

Over heating shut-off device operation:

Operating the refrigerator in high ambient temperatures can over heat the cooling unit and cause premature failure of the compressor (See the label inside the refrigerator).

To protect the cooling unit from over heating, the refrigerator will automatically shut-off when the temperature of the power module is higher than 100° C. The refrigerator will not restart until the temperature of the power module is lower than 80° C.

Low voltage protection system:

In order to prevent completely draining the battery, the refrigerator will automatically shut-off when the DC supply voltage becomes too low. The refrigerator will not restart until the DC supply voltages increases. These shut-off and restart voltage levels are:

12VDC Operation

Shut-off 10.4 VDC

Restart 11.7 VDC

Over current protection system:

Your refrigerator has an over current protection system in the electronic circuit to prevent damage to the inverter which may occur due to a reverse polarity connection.

If the refrigerator does not operate and the blue power light does not come on, check the fuse, which is located in-line with the DC connector, and the polarity of the DC power supply. If the refrigerator still does not operate, another problem can exist in the power module. Have an authorized Thetford Service Center check the refrigerator.

Refrigerator Maintenance Checklist

Read and understand the following maintenance sections of this manual.

NOTICE

Thetford is not responsible for installation, adjustment, alteration, service, or maintenance performed by anyone other than an authorized Thetford Service Center.

Have an authorized Thetford Service Center do these annual safety and maintenance checks:

- Make sure the DC voltages are correct (See the “Electrical current necessary” section).
- The wire connections must be clean, tight and free of corrosion. If any of these items are not correct:
 - A voltage drop to the refrigerator will occur.
 - The voltage drop will decrease the cooling performance of the refrigerator.

CAUTION

Disconnect the positive (+) DC power supply wire from the battery before you do a “fast charge” of the battery. Failure to disconnect the positive (+) power supply wire from the battery during a “fast charge” can cause damage to the refrigerator or other 12 volt DC appliances.

- Make sure the area at the rear of the refrigerator is free of anything, especially combustible materials, gasoline, and other flammable vapors and liquids.

Replacement Parts

You may purchase replacement parts through your dealer or an authorized Thetford Service Center.

CAUTION

If the supply cord is damaged, it must be replaced by the manufacturer, its service agent or similarly qualified persons in order to avoid a hazard.

- The LED lamps can only be replaced by the manufacturer, together with part of the appliance.

Wiring Pictorial

The parts of the wiring pictorial are (See Art2739):

- 1.....Display Module
- 2.....Input Power 12VDC
- 3.....Fuse 25A
- 4.....Main PCBA Cooling Unit
- 5.....Fan Cooling Unit
- 6.....Interior Frozen Food Thermistor
- 7.....Interior Refrigerator Thermistor
- 8.....Interior Light
- 9.....Interior Fan
- 10.....LED Switch
- 11.....Magnet Valve

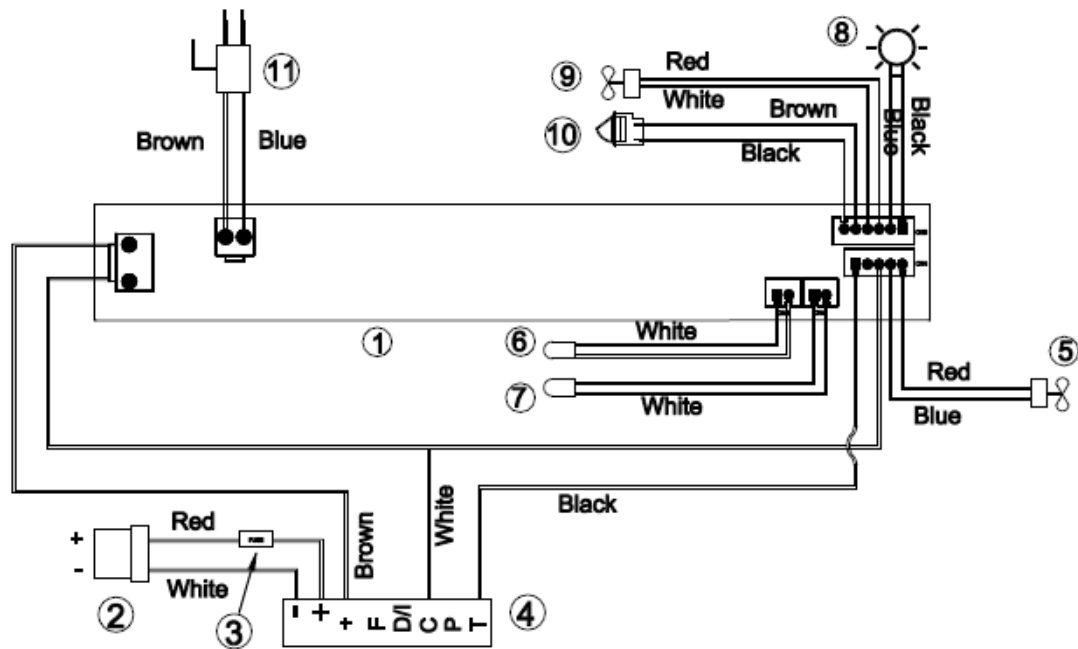

ART 02739