

VITRIFRIGO SLIM150

Total Volume	140 lt
Freezer Compartment	16 lt
Net Weight	42 Kg
Power Supply & Nominal Consumption	12/24V DC 47 W



NIGHT MODE
Reduced consumption
& noise at night



TURBO MODE
Rapidly achieves chill
temperature set point



VENT POSITION
Keeps the door slightly ajar
to prevent mold, mildew and bacteria
and unpleasant odours



3-STAR FREEZER
The 16 litre three-star freezer
can maintain a temperature of -18° C

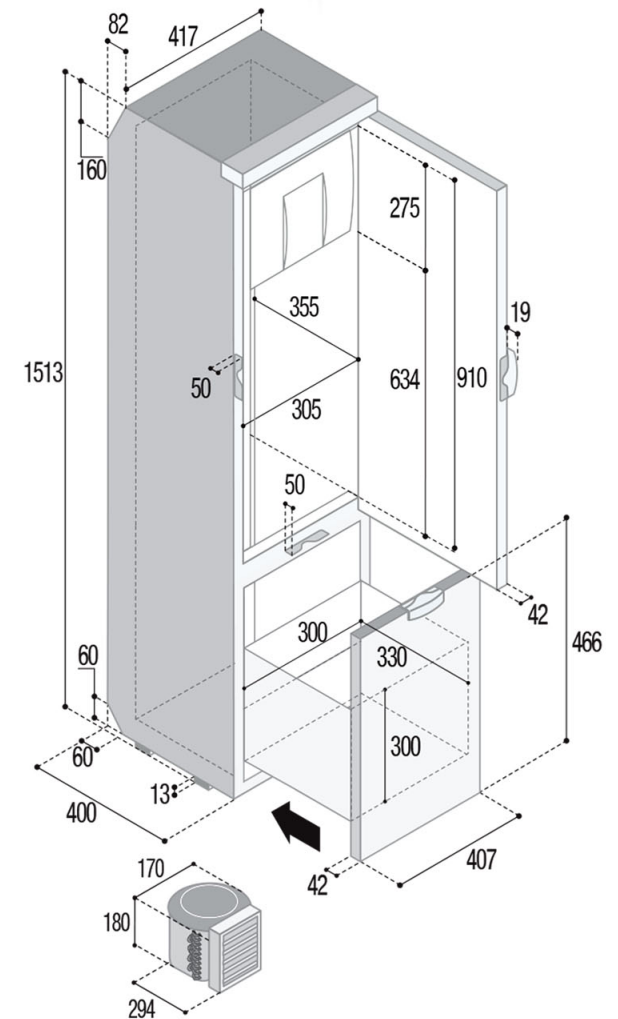

Only available as



FRIDGE+FREEZER